

INFORMATION TO USERS

This manuscript has been reproduced from the microfilm master. UMI films the text directly from the original or copy submitted. Thus, some thesis and dissertation copies are in typewriter face, while others may be from any type of computer printer.

The quality of this reproduction is dependent upon the quality of the copy submitted. Broken or indistinct print, colored or poor quality illustrations and photographs, print bleedthrough, substandard margins, and improper alignment can adversely affect reproduction.

In the unlikely event that the author did not send UMI a complete manuscript and there are missing pages, these will be noted. Also, if unauthorized copyright material had to be removed, a note will indicate the deletion.

Oversize materials (e.g., maps, drawings, charts) are reproduced by sectioning the original, beginning at the upper left-hand corner and continuing from left to right in equal sections with small overlaps. Each original is also photographed in one exposure and is included in reduced form at the back of the book.

Photographs included in the original manuscript have been reproduced xerographically in this copy. Higher quality 6" x 9" black and white photographic prints are available for any photographs or illustrations appearing in this copy for an additional charge. Contact UMI directly to order.

U·M·I

University Microfilms International
A Bell & Howell Information Company
300 North Zeeb Road, Ann Arbor, MI 48106-1346 USA
313/761-4700 800/521-0600

Order Number 9417488

Long-range polyrhythms in Elliott Carter's recent music

Link, John F., Ph.D.

City University of New York, 1994

Copyright ©1994 by Link, John F. All rights reserved.

U·M·I
300 N. Zeeb Rd.
Ann Arbor, MI 48106

A

LONG-RANGE POLYRHYTHMS IN ELLIOTT CARTER'S RECENT MUSIC

by

JOHN F. LINK

A dissertation submitted to the Graduate Faculty in Music in partial fulfillment of the requirements for the degree of Doctor of Philosophy, The City University of New York.

1994

© Copyright 1994

JOHN F. LINK

All Rights Reserved

This manuscript has been read and accepted for the Graduate Faculty in Music in satisfaction of the dissertation requirement for the degree of Doctor of Philosophy.

1 Nov. 1993
Date

Chair of Examining Committee
Philip Lambert

2 November 1993
Date

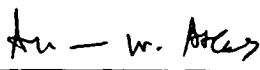
Executive Officer
Allan W. Atlas

Joel Lester

Andrew Mead

Carol Oja

David Olan

Joseph Straus

Supervisory Committee

THE CITY UNIVERSITY OF NEW YORK

Abstract

LONG-RANGE POLYRHYTHMS IN ELLIOTT CARTER'S RECENT MUSIC

by

John F. Link

Advisor: Professor Joseph N. Straus

Although Elliott Carter (b. 1908) is recognized around the world as one of the foremost composers of the late twentieth century, the music he composed in the 1980s — one of the most productive periods of his career — has received very little scholarly attention. During that time Carter developed a clear and expressive rhythmic language, based on long-range polyrhythms, that imparts a new sense of global organization to his recent works, and has significant implications for the more general theoretical issue of rhythm in post-tonal music. This dissertation is a study of long-range polyrhythms in Carter's music from *Night Fantasies* (1980) to *Anniversary* (1989). Chapter 1 considers the abstract properties of long-range polyrhythms. Chapter 2 examines the types of polyrhythms Carter has favored in his recent works and his decisions regarding their notation. In chapter 3 questions about the musical palpability of long-range polyrhythms are addressed from the point of view of the listener/analyst, and numerous examples are given of how long-range polyrhythms can enrich our hearing of Carter's recent music.

Acknowledgements

I would like to thank the members of my dissertation committee — Phil Lambert, who served as chair, Joel Lester, Andrew Mead, Carol Oja, David Olan, and especially my advisor Joe Staus, for their council and encouragement.

I also would like to extend my thanks to the following for their assistance:

The three surviving dedicatees of *Night Fantasies* Gilbert Kalish, Ursula Oppens, and Charles Rosen, generously agreed to be interviewed during my initial work on this project. I learned a great deal from their passionate involvement with Carter's music.

A fellowship from the Paul Sacher Foundation in Basel, Switzerland made possible my study of the *Night Fantasies* sketches. I would like to thank Felix Meyer, Johanna Blask, and the entire staff of the Foundation. Thanks also to Ingrid and Martin Metzger for welcoming me into their home, and to Jonathan Bernard for his insights into Carter's music, and for bringing a number of rhythmic sketches to my attention in Basel.

A fellowship from the Centres Acanthes made it possible for me to attend the festival of Elliott Carter's music held in Avignon in July, 1991, and to meet the composer in especially favorable circumstances.

My parents, of course, made me possible, but their love, support, advice both personal and professional, and especially the example of their lives is a part of every word and note herein.

Finally, to Elliott Carter himself I owe an enormous debt of gratitude, first and foremost for the inestimable gift to the world of his music, but also for the remarkable generosity of time and spirit he showed to an unknown

graduate student who requested an interview. The opportunity to speak to Mr. Carter about his recent works was invaluable for the present study.

Excerpts from *Triple Duo*, *Esprit Rude/Esprit Doux*, *Penthode*, String Quartet No. 4, *Oboe Concerto*, and *Enchanted Preludes*, reprinted by permission of Hendon Music, Inc., a Boosey & Hawkes company.

Excerpts from *Sonata for Violoncello and Piano*, and *Night Fantasies*, copyright © by Associated Music Publishers, Inc. (BMI). International Copyright Secured. All Rights Reserved. Used by Permission.

Table of Contents

Long-Range Polyrythms in Elliott Carter's Recent Music

Abstract	iv
Acknowledgements	v
Abbreviations of Terms Defined in the Text	viii
List of Figures	ix
List of Examples	xii
Introduction	1
Chapter 1 - The Abstract Properties of Long-range Polyrythms	8
Chapter 2 - Carter's Polyrythmic Choices	34
Chapter 3 - Analytical and Perceptual Issues	66
Conclusions	114
List of Works Cited	121

Abbreviations of Terms Defined in the Text

P = the pulsation total of a polyrhythmic stream.

P_i = the pulsation total of the 'i'th stream of a polyrhythm.

C = the cyclic duration of a polyrhythm.

C_n = the numerator of a fractional cyclic duration.

C_d = the denominator of a fractional cyclic duration.

S = the speed of a polyrhythmic stream (measured in pulsations per minute).

S_i = the speed of the 'i'th stream of a polyrhythm.

T = the notated tempo.

T_n = the numerator of a fractional notated tempo.

T_d = the denominator of a fractional notated tempo.

B = the number of notated beats between pulsations.

List of Figures

CHAPTER 1

Figure 1.1 - A polyrhythm of 5:3	9
Figure 1.2 - The ratio of the durations between pulsations (D) is the reciprocal of the ratio of the pulsation totals (P)	9
Figure 1.3 - 1 cycle of the polyrhythm 10:6 = 2 cycles of the polyrhythm 5:3	10
Figure 1.4 - Prime factorizations of the pulsation totals of the <i>Night</i> <i>Fantasies</i> polyrhythm.....	10
Figure 1.5 - A polyrhythm of 5:3, with retrograde-symmetrical resultant rhythm.....	11
Figure 1.6 - A proximity cycle for the polyrhythm 25:21.	13
Figure 1.7 - Spans of maximum convergence for a 25:21 polyrhythm.	15
Figure 1.8 - The entire 25:21 polyrhythm.....	17
Figure 1.9 - Maximum span differences for a polyrhythm of 8:5.	19
Figure 1.10 - Region of maximum divergence for a 25:21 polyrhythm.	21
Figure 1.11 - Regions of maximum divergence in a polyrhythm of 7:5.	22
Figure 1.12 - A portion of the 7:5 polyrhythm showing overlapping regions of maximum divergence.....	23
Figure 1.13 - A polyrhythm of 8:3.....	24
Figure 1.14 - A polyrhythm of 5:3:6 with partial coincidence points.....	25
Figure 1.15 - The 5:3:6 polyrhythm re-written to be out of phase.....	26
Figure 1.16 - The 5:3 polyrhythm with durations measured in seconds.	28
Figure 1.17 - Calculating the speed of a polyrhythmic stream.	29

Figure 1.18 - The ratio of the speeds equals the ratio of the pulsation totals.....	29
Figure 1.19 - The speeds of the streams of the <i>Night Fantasies</i> polyrhythm.....	30
Figure 1.20 - Calculating the number of notated beats between pulsations.....	31
Figure 1.21 - Calculating the number of notated beats between pulsations of the slow stream of the <i>Night Fantasies</i> polyrhythm.....	32
Figure 1.22 - Two pulsations of the slow stream in <i>Night Fantasies</i> , notated in 4/4 time at a tempo of $\downarrow = 126$	32
Figure 1.23 - The formula for the number of beats between pulsations.....	33

CHAPTER 2

Figure 2.1 - The formula for the number of beats between pulsations.....	40
Figure 2.2 - Calculating the number of notated beats between pulsations of the <i>Night Fantasies</i> polyrhythm at a tempo of $\downarrow = 126$	41
Figure 2.3 - Beat division formulas for <i>Esprit Rude/Esprit Doux</i>	42
Figure 2.4 - Beat divisions in the Oboe Concerto for fractional tempi with a denominator value of three.....	43
Figure 2.5 - The number of beats between pulsations in <i>Triple Duo</i>	45
Figure 2.6 - The number of beats between pulsations in <i>Triple Duo</i>	46
Figure 2.7 - The number of beats between pulsations of the slow stream in <i>Night Fantasies</i> at a tempo of $\downarrow = 54$	47
Figure 2.8 - Regrouping the number of beats between pulsations.....	47

Figure 2.9 - Prime factorizations of the pulsation totals in String Quartet No. 4.....	50
Figure 2.10 - Beat division formulas for String Quartet No. 4.....	51
Figure 2.11 - Beat division formulas for String Quartet No. 4.....	52
Figure 2.12 - Beat division formulas for String Quartet No. 4 at a tempo of 84.....	55
Figure 2.13 - Pulsation totals of the <i>Penthode</i> polyrhythm.....	57
Figure 2.14 - Beat division formulas for the <i>Penthode</i> polyrhythm.....	63
Figure 2.15 - Beat division formulas for the <i>Penthode</i> polyrhythm at a tempo of $\downarrow = 84$	64

CHAPTER 3

Figure 3.1 - Metric layering the cello part in the excerpt from <i>Enchanted Preludes</i> (Example 3.6).....	78
Figure 3.2 - Beat division formulas for the Oboe Concerto polyrhythm at a tempo of $\downarrow = 70$	79
Figure 3.3 - Speeds in the Oboe Concerto.....	85
Figure 3.4 - Prime factorizations of the pulsation totals in String Quartet No. 4.....	96
Figure 3.5 - Greatest common factors among pulsation totals in String Quartet No. 4, and a diagram of partial coincidence points.....	97

List of Examples

CHAPTER 2

Example 2.1 - Cello Sonata, mm. 12-22.....	35
Example 2.2 - <i>Triple Duo</i> , mm. 4-8.....	38
Example 2.3 - <i>Night Fantasies</i> , mm. 135 - 140.....	48
Example 2.4 - String Quartet No. 4, mm. 127-130.....	53
Example 2.5 - <i>Penthode</i> , mm. 1-15.....	59

CHAPTER 3

Example 3.1 - <i>Esprit Rude/Esprit Doux</i> , mm. 50-61.....	67
Example 3.2 - <i>Night Fantasies</i> , mm. 419-430.....	69
Example 3.3 - Analytical arrangement of <i>Night Fantasies</i> , mm. 41-54.....	71
Example 3.4 - <i>Night Fantasies</i> , mm. 312-318.....	74
Example 3.5 - <i>Night Fantasies</i> , mm. 96-98.....	75
Example 3.6 - <i>Enchanted Preludes</i> , mm. 71 - 76.....	77
Example 3.7 - Reduction and notation of the Oboe Concerto, mm. 92- 113.....	81
Example 3.8 - Reduction and notation of the Oboe Concerto, mm. 125 - 142.....	86
Example 3.9 - <i>Night Fantasies</i> , mm. 319-326.....	91
Example 3.10 - <i>Night Fantasies</i> , mm. 327-328.....	92
Example 3.11 - <i>Night Fantasies</i> , mm. 333-338.....	93
Example 3.12 - <i>Night Fantasies</i> , mm. 352-357.....	95
Example 3.13 - String Quartet No. 4, mm. 112-120.....	98

Example 3.14 - String Quartet No. 4, mm. 303-315.....	100
Example 3.15 - <i>Night Fantasies</i> , mm. 413-415.....	110
Example 3.16 - <i>Night Fantasies</i> , mm. 105 -134.....	102
Example 3.17 - Analytical arrangement of <i>Night Fantasies</i> , mm. 105-124.	105

Introduction

The music of Elliott Carter is recognized around the world as one of the great artistic achievements of the late twentieth century. Of the many fascinating aspects of Carter's oeuvre, none stands out more than its remarkably rich and complex treatment of rhythm. From his early encounters with the music of Charles Ives¹ and Henry Cowell,² to his study of Bach with Nadia Boulanger in the 1930s,³ to his breakthrough works of the 1940s and 50s and beyond, Carter has constantly sought ways to expand the expressive range of rhythm in his music.⁴

In spite of Carter's international reputation and his lifelong engagement with rhythmic matters, the scholarly literature on this aspect of his music is still surprisingly small, notwithstanding the important

¹On the influence of Ives, see Carter's articles reprinted in *The Writings of Elliott Carter*, ed. Else Stone and Kurt Stone (Bloomington and London: Indiana University Press, 1977). These include "The Case of Mr. Ives," 48-51; "Ives Today: His Vision and Challenge," 98-102; "An American Destiny," 143-150; "The Rhythmic Basis of American Music," 160-166; "Shop Talk by an American Composer," 199-211; "Charles Ives Remembered," 258-269; "Brass Quintet," 322-325; and "Documents of a Friendship with Ives," 331-343. Also see David Schiff, *The Music of Elliott Carter* (London: Eulenburg, and New York: Da Capo, 1983), 18-19; and Jonathan W. Bernard, "The Evolution of Elliott Carter's Rhythmic Practice," *Perspectives of New Music* 26, no. 2 (Summer 1988): 165-166.

²On Cowell, see Carter, "Expressionism and American Music," in *Writings of Elliott Carter*, 230-243; and Carter's comment that "...the 'hypothetical' techniques described in Cowell's *New Musical Resources* also furnished me with many ideas." Allen Edwards, *Flawed Words and Stubborn Sounds*, (New York: Norton, 1971), 91.

³Carter has talked about Boulanger's influence on his musical thinking in Edwards, *Flawed Words and Stubborn Sounds*, 50-56. Also see Schiff, *The Music of Elliott Carter*, 19-20.

⁴For Carter's perspective on the subject of rhythm in his music see Elliott Carter, "The Orchestral Composer's Point of View," in *The Composer's Point of View: Essays on Twentieth-Century Music by Those Who Wrote It*, ed. Robert Stephan Hines (Norman: The University of Oklahoma Press, 1970); and "Music and the Time Screen," *Current Thought in Musicology*, ed. John W. Grubbs (Austin: University of Texas Press, 1976) both reprinted in *The Writings of Elliott Carter*, 282-300, and 343-365 respectively. Hereafter page numbers refer to the reprint editions.

contributions of Jonathan Bernard,⁵ David Harvey,⁶ David Schiff,⁷ Anne Shreffler,⁸ and Craig Weston.⁹ The problem is particularly acute for the years after 1980, one of the most productive periods of Carter's career. David Schiff's *The Music of Elliott Carter* goes only to 1980;¹⁰ Jonathan Bernard's discussion of Carter's rhythmic practice ends with the Double Concerto (1961);¹¹ David Harvey's analyses do not take us beyond the Concerto for Orchestra (1969);¹² and Shreffler and Weston both deal with a work from the 1970s: *A Mirror on Which to Dwell* (1975).¹³ With the exception of Schiff's articles in *Tempo*, which update his book, the compositions after 1980 have remained largely unexplored.¹⁴ During this period Carter's rhythmic practice

⁵Bernard, "Elliott Carter's Rhythmic Practice."

⁶David. I. H. Harvey, *The Later Music of Elliott Carter: A Study in Music Theory and Analysis* (New York and London: Garland, 1989).

⁷David Schiff, *The Music of Elliott Carter*; and "Elliott Carter's Harvest Home," *Tempo* 167 (December 1988): 2-13.

⁸Anne Shreffler, "'Give the Music Room': On Elliott Carter's 'View of the Capitol from the Library of Congress' from *A Mirror on Which to Dwell*," unpublished English version of "'Give the Music Room': Elliott Carter's 'View of the Capitol from the Library of Congress' als *A Mirror on Which to Dwell*," in *Quellenstudien II*, trans. and ed. Felix Meyer (Winterthur: Amadeus, 1993), 255-283.

⁹Craig Alan Weston, "Inversion, Subversion, and Metaphor: Music and Text in Elliott Carter's 'A Mirror on Which to Dwell.'" D.M.A. diss., University of Washington, 1992.

¹⁰Schiff, *The Music of Elliott Carter*.

¹¹Bernard, "Elliott Carter's Rhythmic Practice."

¹²Harvey, *The Later Music of Elliott Carter*.

¹³Shreffler, "'Give the Music Room'," and Weston, "Inversion, Subversion, and Metaphor."

¹⁴The articles include Schiff, "Elliott Carter's Harvest Home;" "'In Sleep, In Thunder': Elliott Carter's Portrait of Robert Lowell," *Tempo* 142 (September 1982): 2-9; and "First Performances: Carter's Violin Concerto," *Tempo* 174 (September 1990): 22-24.

has undergone fundamental changes, characterized most notably by the use of long-range polyrhythms to guide both the large-scale and the local rhythmic design of nearly every major work he has written during the past thirteen years.

Carter's interest in long-range polyrhythms dates back to at least the early 1960s. In his conversation with Allen Edwards, *Flawed Words and Stubborn Sounds*, published in 1971, Carter remarked

...I was aware that one of the big problems of contemporary music was that irregular and other kinds of rhythmic devices used in it tended to have a very small-scale cyclical organization—you heard patterns happening over one or two measures and no more. For this reason, one of the things I became interested in over the last ten years was an attempt to give the feeling of both smaller and larger-scale rhythmic periods. One way was to set out large-scale rhythmic patterns before writing the music, which would then become the important stress points of the piece, or section of a piece. These patterns or cycles were then subdivided in several degrees down to the smallest level of the rhythmic structure, relating the detail to the whole.¹⁵

The type of layered rhythmic organization to which Carter refers emerged gradually in his own work. Both the introduction and the coda of the Double Concerto for Harpsichord and Piano with Two Chamber Orchestras (1961), involve polyrhythms of substantial duration, as does the second movement of the Piano Concerto (1965).¹⁶ The Concerto for Orchestra

¹⁵Edwards, *Flawed Words and Stubborn Sounds*, 111.

¹⁶Thorough analyses of the rhythmic organization of these compositions have yet to appear. For a discussion of the introduction and coda of the Double Concerto see Bernard, "Elliott Carter's Rhythmic Practice," 188-198; Carter, "The Orchestral Composer's Point of View," 292-297; and Schiff, *The Music of Elliott Carter*, 213-215. All three authors describe the rhythmic organization of the opening of the Double Concerto as ten streams of equidistant pulsations grouped into two systems of five streams each. Pulsations from each stream of one system coincide on the downbeat of m. 45, and from each stream of the other system on the downbeat of m. 46. It is noteworthy that none of the authors mentions that these successive coincidence points are the result of a cut Carter made in one of the systems in m. 41, so that its coincidence point comes one measure early. Had both systems followed the pattern set in motion at the beginning of the piece, their coincidence points would have occurred simultaneously on the

(1969), which dates from the same time as the above quotation, was modelled on a single cycle of a polyrhythm of 7:8:9:10.¹⁷ But the thoroughly integrated, layered rhythmic organization which Carter describes has not been demonstrated convincingly for the works of the 1960s, and in the instrumental works of the early 1970s Carter moved away from the kind of global polyrhythmic conception he had sought in the Concerto for Orchestra, and began to focus on polyrhythms of a more limited scope.¹⁸

Carter again became interested in long-range polyrhythms in *A Mirror on Which to Dwell* (1975), a song cycle on poems of Elizabeth Bishop. In his study of this work, Craig Weston has discussed the polyrhythms that occur in three of the songs, "Anaphora," "Insomnia," and "O Breath."¹⁹ In "Anaphora," and "Insomnia" segments of polyrhythms are associated with particular combinations of instruments: piano and vibraphone in "Anaphora," and piccolo and violin in "Insomnia." In "O Breath," part of one cycle of a polyrhythm is shared among all eight of the instrumentalists, not including the singer.

Carter's polyrhythmic practice entered its longest and most significant phase with the composition of *Night Fantasies* (1980). Whereas the long-

downbeat of m. 46. On the Piano Concerto see Carter, "The Orchestral Composer's Point of View," 299; and Schiff *The Music of Elliott Carter*, 231-237.

¹⁷Carter's sketch for the long-range polyrhythm in the Concerto for Orchestra is in the Elliott Carter collection of the Paul Sacher Stiftung in Basel, Switzerland. I am grateful to Jonathan Bernard for bringing this sketch to my attention. Carter briefly alludes to the polyrhythm in "Music and the Time Screen," 357, and in Edwards, *Flawed Words and Stubborn Sounds*, 112. It is described in somewhat more detail in Schiff, *The Music of Elliott Carter*, 253-257, and in David I. H. Harvey, *The Later Music of Elliott Carter, A Study in Music Theory and Analysis* (New York and London: Garland, 1989), 122-129.

¹⁸Richard Derby mentions one such polyrhythm in "Carter's Duo for Violin and Piano," *Perspectives of New Music* 20, nos. 1 and 2 (1981-82): 161-163.

¹⁹Weston, "Inversion, Subversion, and Metaphor," 23-31, 44-59, 140-149, 196-197, and 207-215.

range polyrhythms in his earlier music involved sections of pieces, or played a partial role in the overall development of a composition, in the works of the 1980s they became the central focus of Carter's rhythmic planning. During this period he worked out a clear and expressive rhythmic language that imparts a new sense of global organization to his recent music. The methods Carter developed in *Night Fantasies* proved so successful that he made them the basis for a whole series of works, spanning more than ten years, and involving a wide range of instrumental combinations, from *Changes* for solo guitar (1983) to the recently completed *Partita* (1993) for large orchestra.

Long-range polyrhythms have provided Carter with a new and powerful means of realizing aesthetic aims that have distinguished his music since the late 1940s. As is well known, Carter's compositions are most often made up of two or more contrapuntal layers, each characterized by its own repertory of musical materials and its own patterns of behavior.²⁰ In nearly all of his recent compositions, Carter associates each layer of a composition with a stream of slow periodic pulsations, recurring once about every five to thirty seconds, depending on the piece. When the streams of pulsations are combined they form a polyrhythm. In most cases the streams all coincide once near the beginning of a piece and a second time near the end, so that the overall proportions are determined by the polyrhythm's cyclic pattern.

²⁰References to Carter's stratification of texture are ubiquitous in the composer's own writings, and in the scholarly literature. See, for example, the composer's program notes to the Nonesuch recording H-71234 of the *Sonata for Cello and Piano* (1948) and the *Sonata for Flute, Oboe, Cello, and Harpsichord* (1952), reprinted in *The Writings of Elliott Carter*, 269-273; his program notes for the Nonesuch recording H-71314 of the *Double Concerto for Harpsichord and Piano with Two Chamber Orchestras* (1961) and the *Duo for Violin and Piano* (1974), reprinted in *The Writings of Elliott Carter*, 326-330; David Schiff's discussion of "Stratification" in *The Music of Elliott Carter*, 55; and Jonathan Bernard's of "simultaneity" in "Elliott Carter's Rhythmic Practice," 166.

The pulsations of Carter's polyrhythms are realized in many different ways, and the strength of their articulation on the musical surface varies considerably. With occasional exceptions there is some sort of musical event on every pulsation, but the events themselves are so diverse that the perceptual relevance of the pulsations can never be taken for granted. In many cases, however, they have a decisive impact on the rhythmic organization of a passage, guiding both the patterns of the rhythmic surface and the development of longer sections, and suggesting listening strategies that can help to clarify the music's often daunting complexity.

The present study focuses on Carter's polyrhythmic approach in the works of the 1980s from *Night Fantasies* (1980) to *Anniversary* (1989). It substantially enlarges the repertoire of his compositions represented in the scholarly literature, and has significant implications for important issues in Carter scholarship. In most of his works from 1950 to 1979 Carter took great pride in developing a unique compositional vocabulary from the expressive needs of each new piece. His consistent use of similar materials throughout the 1980s raises questions about the traditional image of Carter's career as one of methodological diversity and change.²¹ Carter's long-range polyrhythms are also of theoretical interest. They demonstrate that local and long-range rhythmic patterns can be coordinated in a thoroughgoing and perceptually compelling way.

What follows is divided into three chapters. Chapter 1 deals with the abstract properties of long-range polyrhythms. It is by nature theoretical and, though examples are drawn from Carter's recent works, it treats the characteristics of long-range polyrhythms in the abstract. Chapter 2 examines the types

²¹Schiff makes a similar point in "Elliott Carter's Harvest Home," 2.

of long-range polyrhythms Carter has favored in his recent works, and his decisions regarding their notation. In chapter 3, questions about the musical palpability of long-range polyrhythms are addressed from the point of view of the listener/analyst, and numerous examples are given of how long-range polyrhythms can enrich our hearing of Carter's recent music.

Chapter 1 — The Abstract Properties of Long-Range Polyrhythms

BASIC CONCEPTS

A *polyrhythm* is defined as a system of two or more streams of periodic *pulsations*.²² A moment in which pulsations from all streams coincide will be called a *coincidence point*, and a polyrhythm in which coincidence points occur will be said to be *in phase*.²³ For in-phase polyrhythms, a *cycle* is the motion from one coincidence point to the next. (Out-of-phase polyrhythms will be considered below.) The amount of time required to traverse one cycle will be called the *cyclic duration*, and the number of pulsations per cycle in a given stream determines the stream's *pulsation total*. Figure 1.1 shows one cycle of a polyrhythm made up of two streams, with pulsations marked off above a scale of units. The pulsation totals are five and three, the cyclic duration is fifteen units, and there is one coincidence point (marked with an arrow) at the beginning of the cycle. (The second coincidence point, in brackets at the end of figure 1.1, marks the beginning of the next cycle.)

²²For a related discussion see Weston, "Inversion, Subversion, and Metaphor," 23-31. Weston modifies David Schiff's term "cross pulse" (*The Music of Elliott Carter*, 26-28) to mean roughly the same as my "polyrhythm." Weston's "cross pulses," though, are implicitly defined to contain two streams (his term is "strands"); when more than two strands are involved he groups them in pairs. Weston also reserves the term "pulse" for situations in which "the listener perceives the temporal structure of the context at hand primarily *in terms of that pulse*." (p. 24, Weston's emphasis). My "pulsations" do not depend on a particular musical context. Their perceptual status will be considered in the analyses of specific passages below.

²³Cf. Weston's "'phase' cycles," discussed below.

Figure 1.1 - A polyrhythm of 5:3.

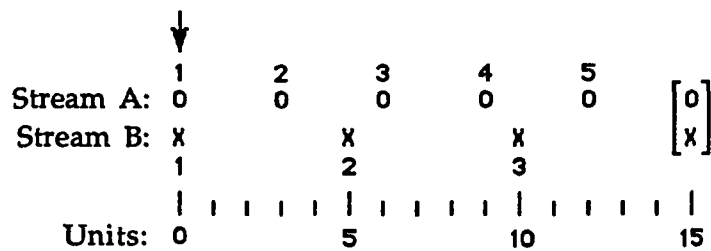

In Figure 1.1 there are three units between pulsations of the fast stream and five units between pulsations of the slow stream.²⁴ Note that the ratio of the durations between pulsations in each stream is the reciprocal of the ratio of the pulsation totals. (See figure 1.2.) This relationship makes good intuitive sense: for a given cyclic duration, the more units there are between pulsations, the fewer pulsations there will be.

Figure 1.2 - The ratio of the durations between pulsations (D) is the reciprocal of the ratio of the pulsation totals (P).

$$\frac{D_2}{D_1} = \frac{5 \text{ units}}{3 \text{ units}} = \frac{5 \text{ pulsations}}{3 \text{ pulsations}} = \frac{P_1}{P_2}$$

The pulsation totals of a polyrhythm cannot have common factors greater than one. In general, for a polyrhythmic segment containing 'n' cycles, 'n' is equal to the greatest common factor of the numbers of pulsations in each stream. An example of such a polyrhythm is given in figure 1.3. Note

²⁴I have followed the numbering system Carter uses in his sketches, counting the first pulsation in each stream as pulsation number one.

that the polyrhythm 10:6 breaks down into two cycles of the simpler polyrhythm 5:3, and that two is the greatest common factor of ten and six.

Figure 1.3 - 1 cycle of the polyrhythm 10:6 = 2 cycles of the polyrhythm 5:3.

(1	2	3	4	5)	(1	2	3	4	5)	[1]	
1	2	3	4	5	6	7	8	9	10	[1]	
0	0	0	0	0	0	0	0	0	0	[0]	
X		X		X	X		X		X	[X]	
1	2	3	4	5	6	7	8	9	10	[1]	
(1	2	3)	(1	2	3)						[1]
└────────── 1st cycle ─────────┘						└────────── 2nd cycle ─────────┘					

For his *Night Fantasies* (1980) for solo piano, Carter chose a polyrhythm of 216:175. The prime factorizations of these numbers are given in Figure 1.4.

Figure 1.4 - Prime factorizations of the pulsation totals of the *Night Fantasies* polyrhythm.

Fast stream: $P = 216 = 2^3 \times 3^3$ Slow stream: $P = 175 = 5^2 \times 7$

Note that the two pulsation totals have only the trivial common factor one, and thus 216:175 represents one cycle of a polyrhythm.

Merging the attacks from all streams into a single line produces a polyrhythm's *resultant rhythm*. The resultant rhythm for the polyrhythm in figure 1.1 is indicated in figure 1.5 by the sequence of "r"s.

based on recurring resultant-rhythm patterns which he calls "'phase'-cycles." Although Weston's analyses are quite compelling, he defines a "'phase'-cycle" only in very general terms, as the "cycle of convergence and divergence of the articulations of the respective pulses of a [polyrhythm]."²⁶ In this section I have taken several steps toward formalizing this definition, and demonstrated how to predict the number of "'phase'-cycles" in certain types of polyrhythms. Because I have used the word "phase" in a very different context, I will substitute the term *proximity cycle* for Weston's "'phase'-cycle." By either name his concept is particularly relevant to Carter's long-range polyrhythmic works of the 1980s.

Here is Weston's description of a typical proximity cycle:

Beginning from the point of maximum convergence, the articulations of the respective pulses [i.e. strands] become [further] and further apart, until they reach the point of maximum divergence, at which point the trend reverses, and they begin to become closer and closer together, until they reach the point of maximum convergence, at which point the trend reverses, and so on.²⁷

An example is given in figure 1.6.

²⁶Ibid., p. 28.

²⁷Ibid.

Figure 1.6 - A proximity cycle for the polyrhythm 25:21.

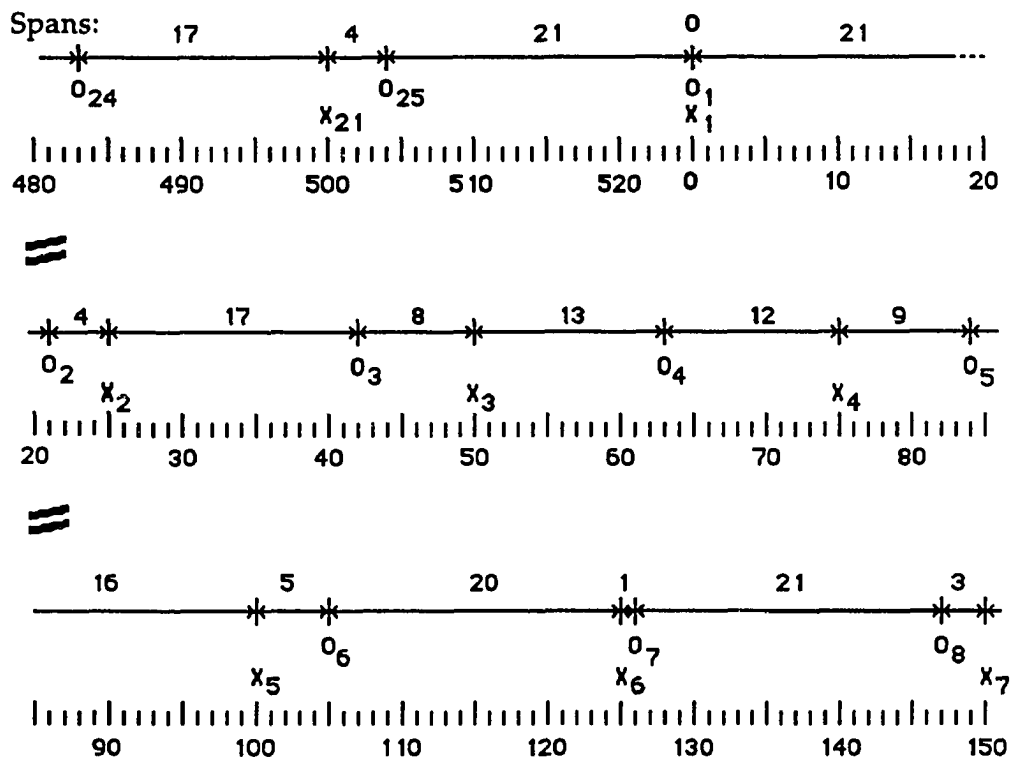

Figure 1.6 shows the last three pulsations of one cycle of a polyrhythm and the first fifteen pulsations of the next.²⁸ Note that pulsations from both streams coincide at unit 0, and then that each successive pulsation in the "X" stream falls a bit further behind the preceding pulsation in the "O" stream. After pulsation O_4 , the pulsations in the "X" stream begin to sound as though they are anticipating those of the "O" stream by shorter and shorter time intervals. When the pulsations in the "O" stream catch up and overtake those in the "X" stream, the pattern begins again.

²⁸The cyclic duration of 525 units was chosen because 525 is the least common multiple of 25 and 21.

We can track this cyclical pattern by examining the *spans* between consecutive attacks of the polyrhythm's resultant rhythm. These spans are also indicated in figure 1.6. The zero written as the fourth span signifies that the distance between the pulsation number 1 of the "X" stream and pulsation number 1 of the "O" stream is zero.

The pattern of convergence and divergence characteristic of a proximity cycle becomes clear when we compare the differences between consecutive spans. To do so, we first take span one minus span two, then span two minus span three, and so on. A list of these *span differences* has been added to the previous figure in figure 1.7.

Figure 1.7 - Spans of maximum convergence for a 25:21 polyrhythm.

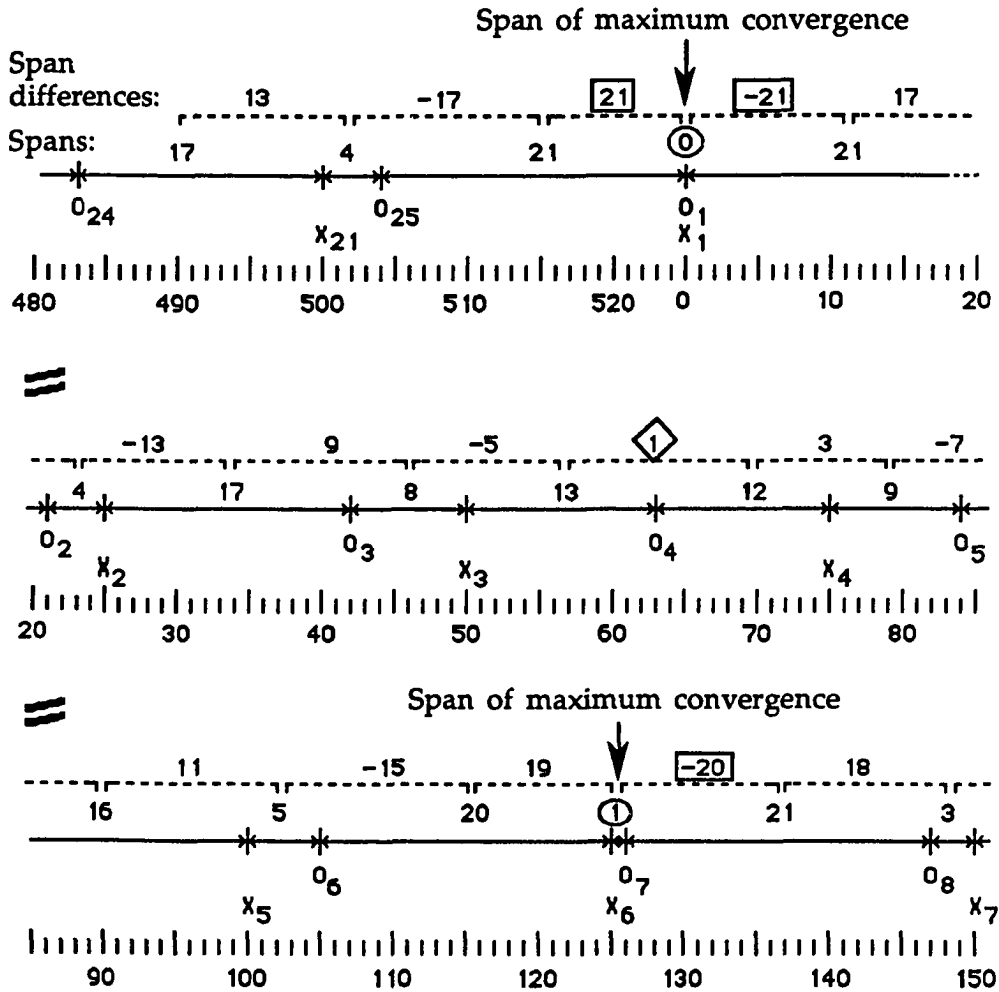

Now a cyclic pattern is evident. The absolute values of the spans start at 13, then become larger until a maximum value of 21 is reached, then decrease to a minimum of one, then increase to a maximum of 20, and so on. In the figure, the three maximum span differences are enclosed in square boxes. Because the consecutive span differences 21 and -21 are equal in absolute value, both have been counted as maxima. Note that the maximum span

differences form axes around which approximately equal span differences are arranged in a symmetrical pattern. The minimum span difference, 1, is enclosed in a diamond-shaped box.

We can use the maximum span differences to define *spans of maximum convergence*.²⁹ If a maximum span difference is positive, the span that immediately *follows* it is the span of maximum convergence. If a maximum span difference is negative, the span that immediately *precedes* it is the span of maximum convergence. In figure 1.7, the first two maximum span differences both point to the span of zero units that begins each cycle. The spans of maximum convergence are circled in the figure. Figure 1.8 gives the entire 25:21 polyrhythm, together with its spans, span differences, and spans of maximum convergence.

²⁹Weston's term is "*point of maximum convergence*" (my emphasis). See "Inversion, Subversion, and Metaphor," 27-29.

Figure 1.8 - The entire 25:21 polyrhythm.

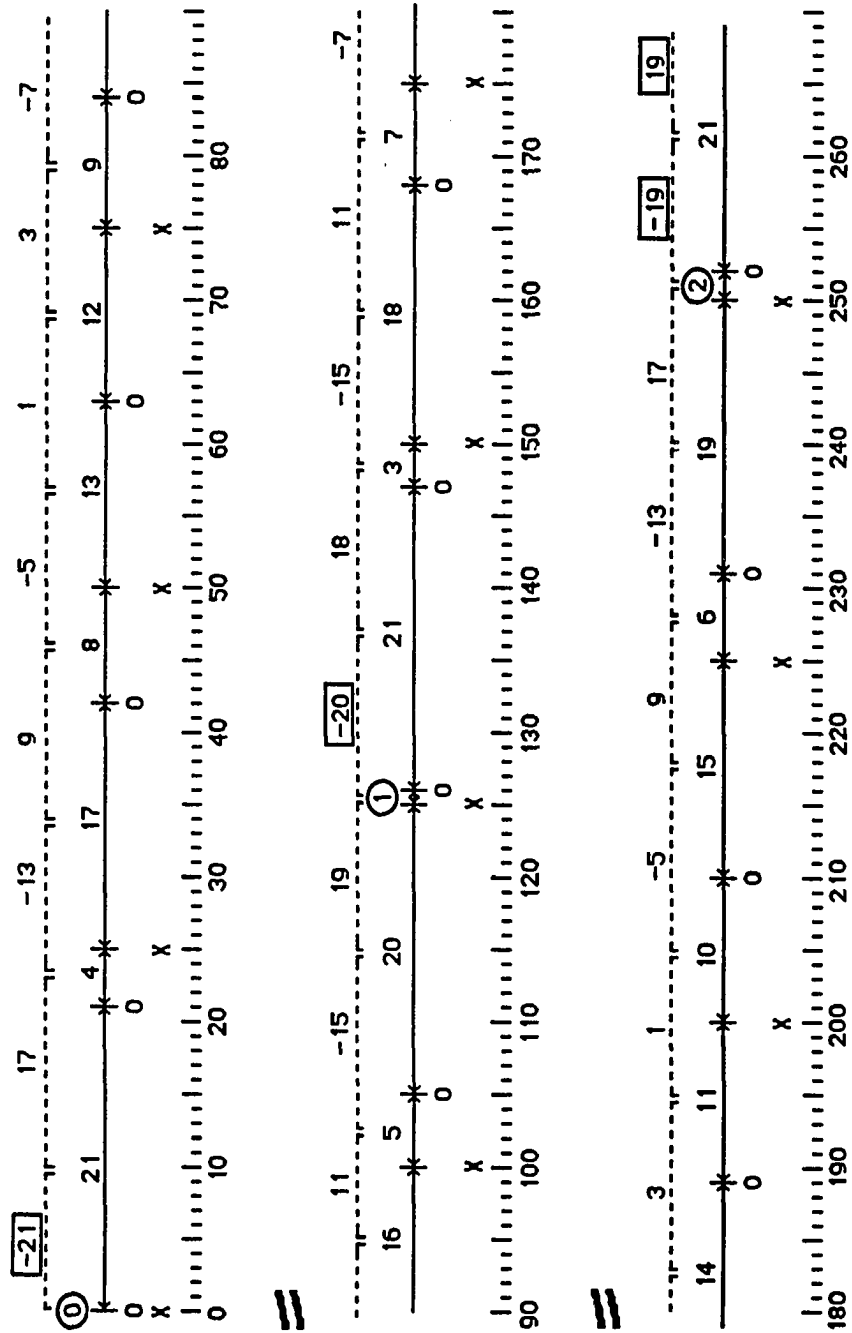

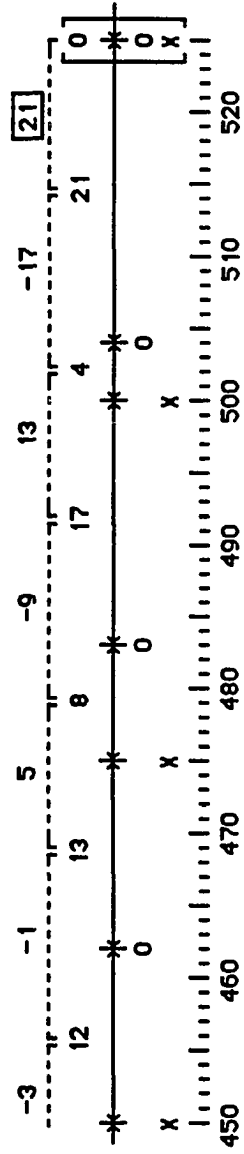
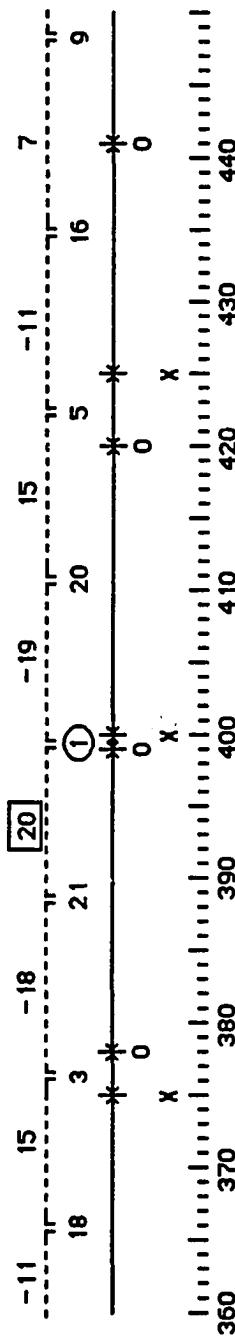
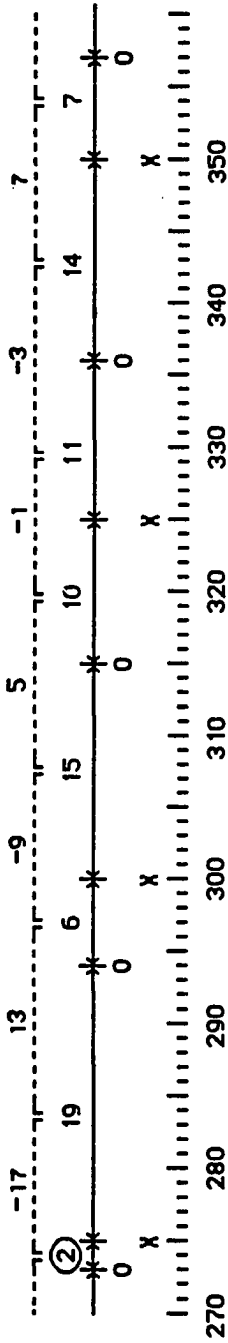

Because the pulsation totals of both streams in figure 1.8 are odd, there are consecutive maximum span differences (-19 and 19) near the halfway point of the polyrhythm. Note that the order of their signs (negative, positive) is reversed from what it was at the beginning of the cycle when the span differences 21 and -21 were in the order positive, negative. This means that at the midpoint of the polyrhythm the consecutive maximum differences point to separate spans of maximum convergence. Again, these spans are circled in the figure.

If a polyrhythm has an even pulsation total, consecutive maximum span differences occur only at the beginning of each cycle, as in the 8:5 polyrhythm shown in figure 1.9.

Figure 1.9 - Maximum span differences for a polyrhythm of 8:5

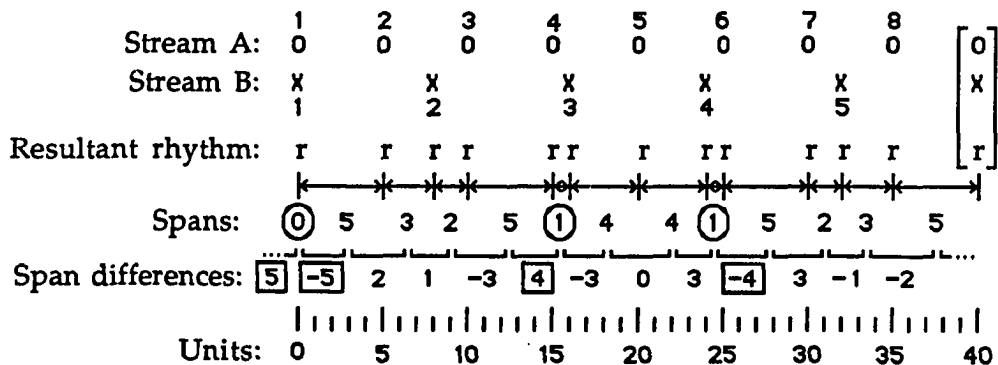

Note that in figure 1.9 the maximum span differences 4 and -4 occur not consecutively at the midpoint of the polyrhythm but on either side of it with some time between.

In general, the number of spans of maximum convergence of a two-stream polyrhythm depends on the difference between the pulsation totals. If

the polyrhythm is in phase, and the pulsation total of one stream is not more than double the pulsation total of the other, we can be quite specific about how many spans of maximum convergence there are. If one of the pulsation totals is even, the number of spans of maximum convergence is equal to the difference between the pulsation totals. In figure 1.9, for example, the pulsation totals are eight and five. Subtracting the smaller from the larger leaves three, and indeed there are three spans of maximum convergence for each cycle of the polyrhythm (they are circled in the figure). If both pulsation totals are odd the number of spans of maximum convergence is equal to the difference between the pulsation totals plus one. In the 25:21 polyrhythm of figure 1.8 for example, the difference between the pulsation totals is four, and there are five spans of maximum convergence.³⁰

Also of analytical interest are the segments of a proximity cycle in which resultant-rhythm attacks are roughly equidistant. Such a segment will be called a *region of maximum divergence*.³¹ An earlier example — the first section of the 25:21 polyrhythm from figure 1.7 — is recalled in figure 1.10.

³⁰Both pulsation totals cannot be even, because if so they would share a common factor of two, and the polyrhythm would contain more than one cycle.

³¹Weston's term is "*point of maximum divergence*" (my emphasis). See "Inversion, Subversion, and Metaphor," 27-29.

Figure 1.10 - Region of maximum divergence for a 25:21 polyrhythm.

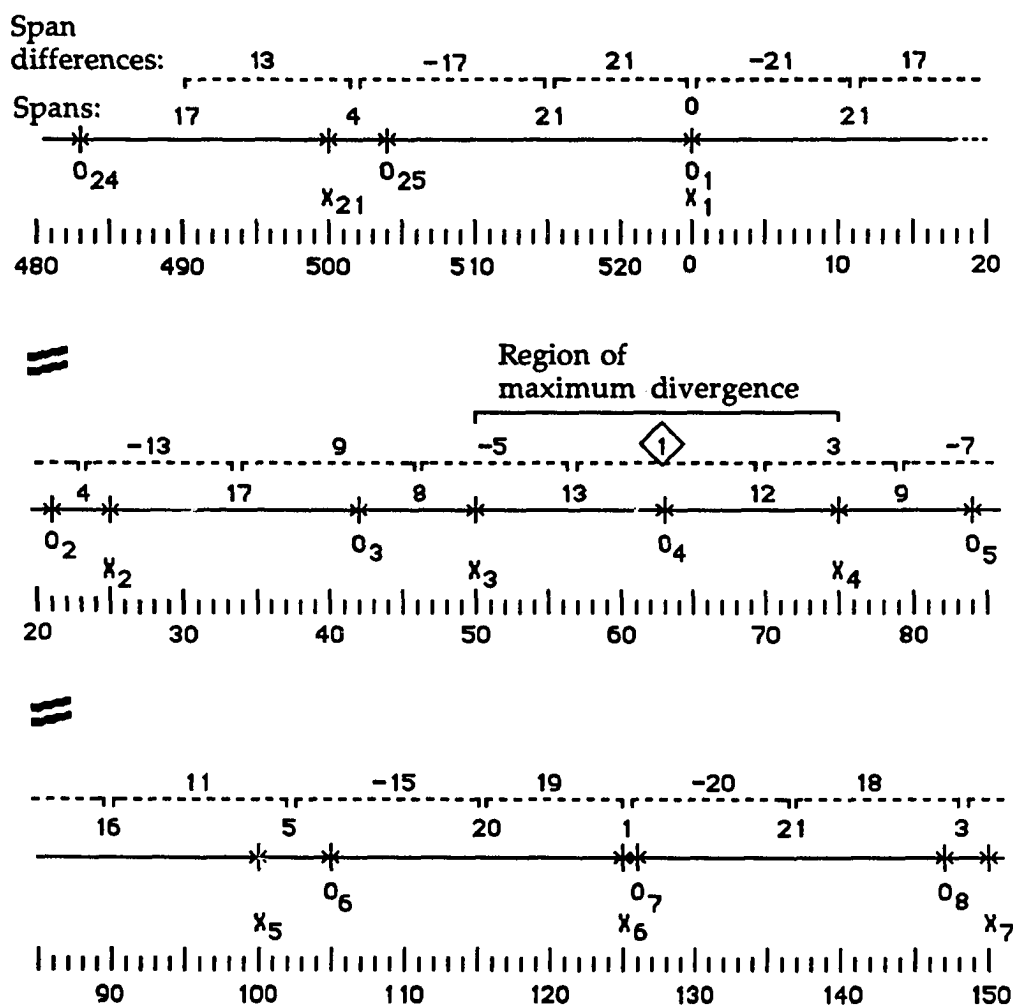

In figure 1.10 there is a single minimum span difference 1, which is enclosed in a diamond-shaped box. The minimum span difference says that the consecutive spans X_3-O_4 , (13 units) and O_4-X_4 (12 units) are approximately equal. These two spans, together with the pulsations that frame them, are the region of maximum divergence.

If a polyrhythm has two consecutive minimum span differences, they define two overlapping regions of maximum divergence. An example occurs in the 7:5 polyrhythm given in figure 1.11. The minimum span differences are again enclosed in diamond-shaped boxes.

Figure 1.11 - Regions of maximum divergence in a polyrhythm of 7:5

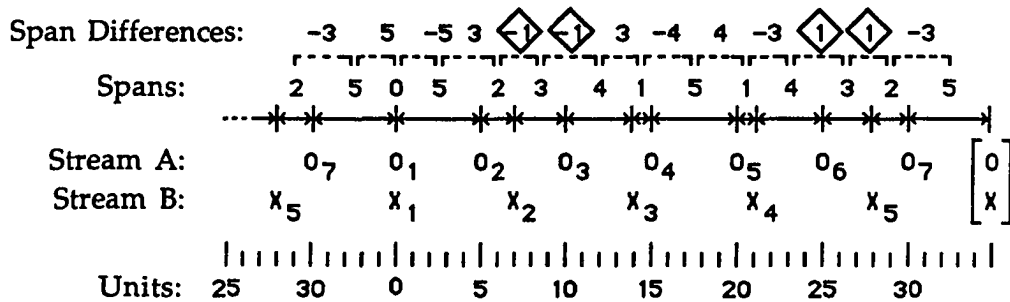
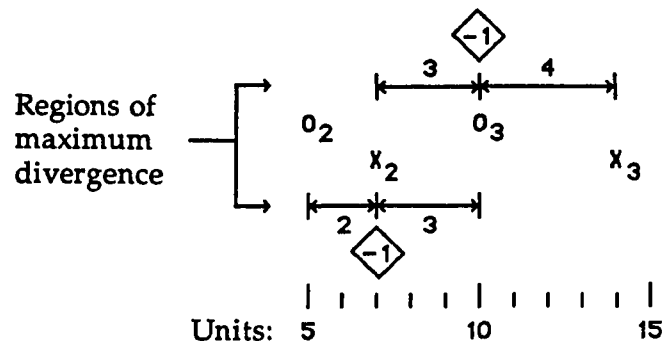

Figure 1.12 gives an enlarged view of one section of the polyrhythm in which the consecutive minimum span differences -1 and -1 occur.

Figure 1.12 - A portion of the 7:5 polyrhythm showing overlapping regions of maximum divergence.



In figure 1.12 each of the consecutive minimum span differences defines its own region of maximum divergence; the span of three units between pulsations X_2 and O_3 is part of both regions.³²

It is often convenient to think of a proximity cycle as the motion from the beginning of one span of maximum convergence to the beginning of the next. But this definition can be problematic near the midpoint of a polyrhythm, when spans of maximum convergence are frequently quite close together. In the 25:21 polyrhythm of figure 1.8, for example, there are no pulsations between consecutive spans of maximum convergence at the midpoint of the polyrhythm. It would make little sense in this case to call the motion between them a proximity cycle.³³ In the 216:175 polyrhythm of *Night Fantasies*, on the other hand, the spans of maximum convergence that

³²It also would be possible to think of the entire segment in figure 1.12 as a single region of maximum divergence bounded by pulsations O_2 and X_3 .

³³In his analysis of the 69:65 polyrhythm in "Anaphora" from *A Mirror on Which To Dwell* Weston avoids this problem by counting the consecutive spans of maximum convergence on either side of the midpoint as a single span which separates the polyrhythm's two proximity cycles.

straddle the midpoint are quite far apart, and there are nine pulsations between them, arranged in a clear convergence/divergence pattern. In this case the spans of maximum convergence clearly delineate a proximity cycle.

In addition to their somewhat odd behavior near the midpoint of a polyrhythm, proximity cycles are subject to some important limitations. First, they apply only to polyrhythms with two streams. In order to apply them to polyrhythms with more than two streams, it is necessary first to group the streams in pairs. Unless there is a compelling musical reason to do so, such groupings can seem arbitrary. Second, the sense of convergence and divergence that proximity cycles are intended to model drops off dramatically in certain cases. As the pulsation totals get smaller, the changes of proximity become more sudden, and the regularity of the patterns of convergence and divergence decreases. A similar result occurs when the pulsation total of one stream is more than twice that of the other. In figure 1.13, for example, the sense of resultant-rhythm attacks moving closer together and further apart has given way to a more stable, regular pattern with occasional interruptions.

Figure 1.13 - A polyrhythm of 8:3.

	1	2	3	4	5	6	7	8	
Stream A:	0	0	0	0	0	0	0	0	0
Stream B:	x			x			x		x
	1			2			3		
Resultant rhythm:	r	r	r	r r	r	r r	r	r	r
Units:	0	5	10	15	20	25			

Despite these limitations, proximity cycles can be a valuable tool for the analysis of Carter's music. The majority of his recent compositions involve

two-stream polyrhythms and fairly large pulsation totals whose ratio is never greater than 2:1. Examples of Carter's use of proximity cycles will be considered in chapter 3.

PARTIAL COINCIDENCE POINTS

For polyrhythms with more than two streams it is possible that pulsations from some, but not all, streams may coincide. Such moments will be called *partial coincidence points*. If a polyrhythm is in-phase, streams whose pulsation totals share a greatest common factor of 'n' will coincide 'n' times per cycle. There will be n-1 partial coincidence points in addition to the (global) coincidence point that begins the cycle. Consider the polyrhythm in figure 1.14 for example.

Figure 1.14 - A polyrhythm of 5:3:6 with partial coincidence points.

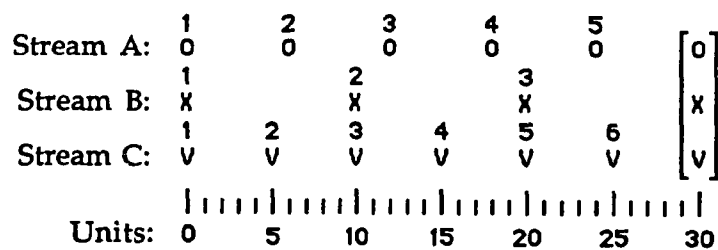

In figure 1.14 the pulsation totals of the three streams are five, three, and six, respectively. Note that these three numbers share no common factors greater than one, and thus the figure shows one cycle of a polyrhythm. But the pulsa-

tion totals of streams "B" and "C" share a greatest common factor of three, which means pulsations from the two streams will coincide three times per cycle.

OUT-OF-PHASE POLYRHYTHMS

All of the polyrhythms considered so far have had coincidence points. But it is also possible that the streams of a polyrhythm may never all coincide. Such a polyrhythm will be said to be *out of phase*. In figure 1.15 the polyrhythm from figure 1.14 has been re-written as an out-of-phase polyrhythm.

Figure 1.15 - The 5:3:6 polyrhythm re-written to be out of phase.

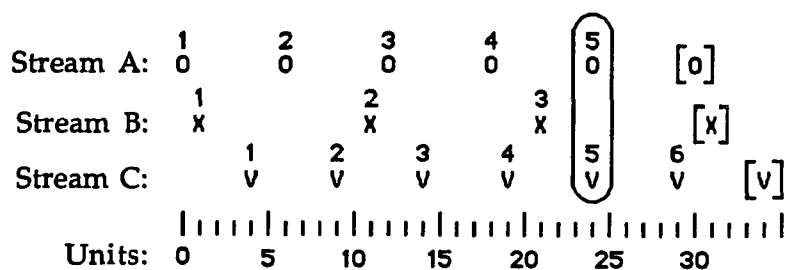

Note that while there are no longer any (global) coincidence points, and the location and number of the partial coincidence points has changed, the polyrhythm in figure 1.15 is nonetheless cyclic: every fifth pulsation after the first in stream "A" will occur exactly one unit before the next pulsation in stream "B" and exactly four units before the next pulsation in stream "C".

Because they have no (global) coincidence points, the definition of *cycle* for out-of-phase polyrhythms must be revised. To do so we first define the *cyclic position* of an arbitrary pulsation 'q' as a list of the spans between 'q' and the next pulsation in each of the other streams. As an example, suppose we take 'q' to be the first pulsation in stream "A" of the polyrhythm in figure 1.15. Then the next pulsation in stream "B" occurs one unit after 'q', and the next pulsation in stream "C" occurs three units after 'q'. We can notate the cyclic position of 'q' as (B1,C3), where the letters refer to the streams that do not contain 'q' and the numbers give the number of units between 'q' and the next pulsation of the given stream.

We can say two pulsations are equivalent if and only if their cyclic positions are the same. Then a cycle of an out-of-phase polyrhythm can be defined as the span between consecutive equivalent pulsations, and the pulsation totals and the cyclic duration can be calculated. Notice that changing the phase of the polyrhythm in figure 1.14 does not change the pulsation totals or the cyclic duration. The polyrhythms in figures 1.14 and 1.15 both have a cyclic duration of thirty units, and pulsation totals of five, three, and six, respectively. Because both the pulsation totals and the cyclic duration of a polyrhythm are unaffected by its phase, the properties of long-range polyrhythms considered below are valid for all types of polyrhythms.

THE SPEED OF A POLYRHYTHMIC STREAM

Thus far we have been considering polyrhythms with reference to an abstract scale of units. Note that the units imply no particular time scale: the polyrhythm of figure 1.1 could last fifteen seconds or fifteen hours, as long as

the chosen duration is divided into five equal durations in one stream and three in the other.³⁴ In Figure 1.16, the 5:3 polyrhythm of figure 1.1 has been re-written with the durations between pulsations measured in seconds.

Figure 1.16 - The 5:3 polyrhythm with durations measured in seconds.

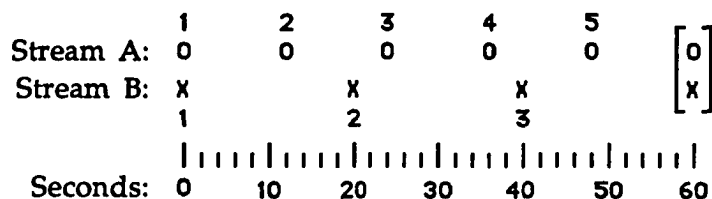

Measuring durations in seconds helps to clarify an important characteristic of polyrhythms: the speed of each stream.

The speed of a stream is the number of pulsations per minute. It can be found by dividing the stream's pulsation total by the cyclic duration measured in minutes. (See figure 1.17.)

³⁴In fact, though I have described polyrhythms measured in time, it would be entirely possible to define the units of figure 1.1 as units of register (i.e. half steps). The "polyrhythm" shown in the figure would then track coincidences in pitch of two streams of pitches spaced three and five half steps apart respectively. See John Rahn, "On Pitch or Rhythm: Interpretations of Orderings Of and In Pitch and Time," *Perspectives of New Music* 13, no. 2 (Spring-Summer 1975): 182-198.

Figure 1.17 - Calculating the speed of a polyrhythmic stream.

$$\text{Speed (S)} = \frac{\text{Pulsation total (P)}}{\text{Cyclic duration (C)}}$$

For example, in figure 1.16 the speed of stream "A" is its pulsation total (5) divided by the cyclic duration (1 minute) giving a speed of five pulsations per minute. Similarly, pulsations in stream "B" occur at a speed of three pulsations per minute. Note that the ratio of the speeds is equal to the ratio of the pulsation totals. (See figure 1.18.)

Figure 1.18 - The ratio of the speeds equals the ratio of the pulsation totals.

$$\frac{S_1}{S_2} = \frac{P_1}{P_2} \quad \left(\frac{\text{MM } 5}{\text{MM } 3} = \frac{5 \text{ pulsations}}{3 \text{ pulsations}} \right)$$

In *Night Fantasies* the cyclic duration is 20 minutes. This number fixes the speeds of the streams at $10\frac{4}{5}$ pulsations per minute for the fast stream, and $8\frac{3}{4}$ pulsations per minute for the slow stream. (See figure 1.19.) The ratio of the speeds is again equal to the ratio of the pulsation totals, in this case 216:175.

Figure 1.19 - The speeds of the streams of the Night Fantasies polyrhythm.

$$\text{Speed of the fast stream} = \frac{216}{20} = 10\frac{4}{5} \text{ pulsations per minute}$$

$$\text{Speed of the slow stream} = \frac{175}{20} = 8\frac{3}{4} \text{ pulsations per minute}$$

The ratio of the speeds equals the ratio of the pulsation totals

$$\frac{S_1}{S_2} = \frac{10\frac{4}{5}}{8\frac{3}{4}} = \frac{\frac{54}{5}}{\frac{35}{4}} = \frac{54}{5} \times \frac{4}{35} = \frac{216}{175} = \frac{F_1}{P_2}$$

NOTATING PULSATIONS

In Elliott Carter's recent works, the pulsations of a long-range polyrhythm are projected onto a range of faster notated tempi indicated by the metronome markings in the finished score. For purposes of analysis, it is more practical to measure the durations between pulsations in numbers of beats at a given tempo, rather than in seconds.³⁵ The number of beats between

³⁵Measuring the durations between pulsations in numbers of beats also provides a useful way to figure out what polyrhythm is produced by a short series of pulsations on a musical surface. For example, consider a polyrhythm in 4/4 time in which pulsations occur every three sixteenths (or $\frac{3}{4}$ of a beat) in one stream against every four quintuplet sixteenths (or $\frac{4}{5}$ of a beat) in another.

The ratio of these durations will be equal to the ratio of the pulsations totals: $\frac{3}{4} : \frac{4}{5} = \frac{\frac{3}{4}}{\frac{4}{5}} =$

pulsations of a given stream is related to the notated tempo, the cyclic duration, and the stream's pulsation total by the formula in figure 1.20.

Figure 1.20 - Calculating the number of notated beats between pulsations.³⁶

$$\text{No. of beats between pulsations} = \text{Tempo} \times \frac{\text{Cyclic Duration}}{\text{Pulsation Total}} = T \times \frac{C}{P} = \frac{T \times C}{P}$$

We can use this formula to find, for example, the number of beats between pulsations of the slow stream of the *Night Fantasies* polyrhythm at any given tempo. Figure 1.21 shows that, at a tempo of $\text{♩} = 126$, pulsations of the slow stream recur every $14\frac{2}{5}$ beats.

$\frac{3}{4} \times \frac{5}{4} = \frac{15}{16}$. This method also works in reverse. A range of possible realizations of a polyrhythm can be determined by factoring each of the pulsation totals and arranging the factors in ratios representing numbers of beats. The polyrhythm 15:16, for example, could be realized as $\frac{3}{4} : \frac{4}{5}$ or $\frac{3}{2} : \frac{8}{5}$ or $\frac{5}{8} : \frac{2}{3}$ etc.

³⁶In figure 1.17 we saw that the speed of a stream (S) = $\frac{P}{C}$. Thus the formula in figure 1.20 could also be written as $T \times \frac{1}{S}$ or $\frac{T}{S}$. This is the version found most frequently in Carter's sketches. (For an example, see the transcription in Schiff "Elliott Carter's Harvest Home," 3. In the first part of Schiff's transcription $T = 50.05$ and $\frac{1}{S} = \frac{3}{91}$. Multiplying $T \times \frac{1}{S}$ gives a speed of MM 1.65.) I have chosen to use the somewhat more cumbersome formula given in figure 1.20 in order to emphasize the roles played by the pulsation totals and the cyclic duration.

Figure 1.21 - Calculating the number of notated beats between pulsations of the slow stream of the *Night Fantasies* polyrhythm.

$$\text{No. of beats between pulsations} = B = \frac{T \times C}{P} = \frac{126 \times 20}{175} = \frac{72}{5} = 14\frac{2}{5} \text{ beats}$$

In figure 1.22 I have used the result of figure 1.21 to write out two hypothetical pulsations of the slow stream from *Night Fantasies*, assuming 4/4 time and a tempo of $\text{♩} = 126$. Notice that a beat division of 5, in this case quintuplet sixteenths, must be used in order to notate the last $\frac{2}{5}$ of a beat accurately, and that the operative beat division is determined by the denominator of the number-of-beats-between-pulsations formula.

Figure 1.22 - Two pulsations of the slow stream in *Night Fantasies*, notated in 4/4 time at a tempo of $\text{♩} = 126$.

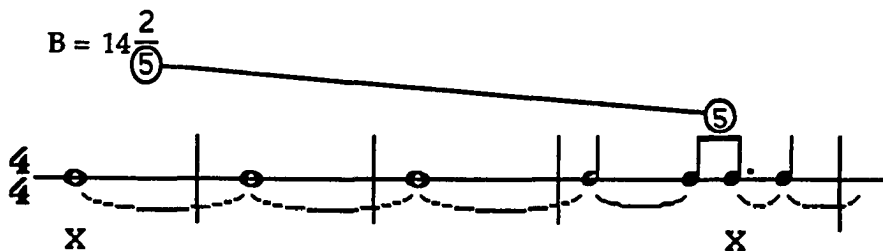

As we will see, the level of beat division required to notate pulsations accurately has significant implications for Carter's polyrhythmic works. But how, in general, is this level of beat division constrained? To answer this

question it will be helpful to modify the formula from figure 1.20 to account for fractional tempo indications and cyclic durations, since both occur frequently in Carter's music. The modified formula is given in figure 1.23, with the subscripts "n" and "d" used to indicate numerator and denominator respectively. Note that now all the factors of both numerator and denominator are whole numbers.

Figure 1.23 - The formula for the number of beats between pulsations.

$$\text{No. of beats between pulsations} = B = \frac{T \times C}{P} = \frac{\frac{T_n}{T_d} \times \frac{C_n}{C_d}}{P} = \frac{T_n \times C_n}{T_d \times C_d \times P}$$

In figure 1.22 we saw that the the level of notated beat division required to notate pulsations accurately is determined by the denominator of the number-of-beats-between-pulsations formula. This result is true in general. Once the fraction in figure 1.23 is reduced to lowest terms, the denominator gives the desired level of beat division. Notice that this number depends not only on the tempo, but on the cyclic duration and the pulsation total as well, a relationship which suggests that considerations of large-scale rhythmic organization (such as pulsation totals and cyclic duration) have a decisive influence on the details of the rhythmic surface (such as beat division). This suggestion, and its implications for Carter's recent music will be examined further in the following chapters.

Chapter 2 — Carter's Polyrhythmic Choices

While the general properties of long-range polyrhythms are of considerable interest, for Elliott Carter they are a means to an end. Specifically, they serve to facilitate one of his most enduring expressive concerns. As he puts it: "I think that the basic thing that this all comes from is an effort to combine different strands of music that have different characters...."³⁷

Two important elements of Carter's mature style are implicit in this remark. First, the strong characterization of different layers of music, and second, their dramatic, contrapuntal interaction. In his recent works Carter has continued to explore the stratified textures that have long been a hallmark of his music. Using long-range polyrhythms he has clarified the relationships among the layers, and given each a role in a global rhythmic plan that is regular and predictive on a large scale, yet allows for a highly flexible and varied musical surface.

The connection between large-scale and surface rhythm is made by means of a technique Carter has used before, albeit sparingly: the notation of each layer of music using a different division of the notated beat. Example 2.1 shows a passage near the beginning of the Sonata for Violoncello and Piano of 1948.

³⁷Interview with the author, 8/31/92.

Example 2.1 - Cello Sonata, mm. 12-22.

The image displays a musical score for a Cello Sonata, specifically measures 12 through 22. The score is written for three staves: a single bass clef staff at the top, and a grand staff (treble and bass clefs) below it. The key signature is one sharp (F#), and the time signature is 3/4. The first system covers measures 12 to 15. The second system covers measures 16 to 22. The score includes various musical notations such as slurs, accents, and dynamic markings. The word "simile" is written above the grand staff in measure 16, and "mf espress." is written below it in measure 18. Measure numbers 15 and 20 are enclosed in boxes above the staves. A piano dynamic marking "(p)" is present in measure 22.

In this excerpt, the piano plays an almost mechanical series of quarter notes, *un poco incisivo*, while the cello unfolds a rhapsodic, "quasi rubato" melody the notes of which never coincide with those of the piano. Note that the cello's attacks in these measures always involve a three-part beat division — they occur only on the second or third triplet eighth of a notated beat. Attacks in the piano, on the other hand, always involve a one-part beat division, since they occur only *on* a notated beat. The notated beat divisions do not necessarily encourage a particular metric grouping — it would be difficult (and not particularly rewarding) to hear the triplet beat divisions in the cello line in groups of three. Rather, the beat divisions define a series of equal units — a one-dimensional grid of pulses — with which an instrument's attacks are aligned.³⁸ The pulses of the grid are fast enough to allow for a wide variety of surface rhythms. They may be grouped by the attacks of the instruments into any number of patterns, occasionally subdivided, or, as in the cello line of the previous example, they may suggest a written-out rubato. The "three-ness" of the cello's beat division refers not to the groupings of the pulses, but to their speed: they move three times as fast as the notated beat. The notated beats themselves serve as points of reference for the performers, allowing them to coordinate the different speeds of their respective grids. In a good performance the notated beats should not be audible in the cello, since a

³⁸The analogy between a layer's consistent beat divisions and a grid of pulses was suggested by a remark of Carter's:

Well, in the early days I began to think of it. When we were in St. John's College we talked a lot about things like this and I remember we talked a lot about Descartes. And Descartes was of course one of the first to discover that you could make a grid and then make graphs on it that were irregular patterns but that they could all be expressed in numbers. And it was that kind of an idea that I had of having irregular rhythms that would also have a regular background. (Interview with the author, 8/31/92.)

perceptible common pulse would undermine the sense of rhythmic independence among the layers.³⁹

As Jonathan Bernard has pointed out, the rhythmic stratification of instruments found in the previous example is not maintained throughout the composition.⁴⁰ And even in later works in which a stratified texture is the norm, such as the *String Quartet No. 3*, Carter rarely assigns a consistent pulse grid to a single layer for more than a few measures at a time. But in his compositions after 1980 stratification by beat division becomes a central feature of his rhythmic style.

The change is clearly noticeable in the opening of *Triple Duo* (1982/83), Carter's first instrumental work after *Night Fantasies*. Measures 4-8 are given as example 2.2.

The stratification of the instruments into three pairs suggested by the title is easily inferable from Carter's beat divisions. The flute and clarinet play beat divisions of three, the piano and percussion play beat divisions of five, and the violin and cello play beat divisions of four. The association of a unique beat division with each layer of *Triple Duo* is maintained for the duration of the piece, through several different tempi and meters, and a wide variety of characters and moods. At a given tempo, the contrasting beat divisions establish pulse grids moving at different speeds, and the contrasting speeds help to emphasize the rhythmic independence of the layers.

³⁹Charles Rosen makes a similar point in "One Easy Piece," in *New York Review of Books* 20, no. 2 (22 February 1973), reprinted in *The Musical Languages of Elliott Carter*, (Washington: Library of Congress, 1984), 26-27. Hereafter page numbers refer to the reprint edition. Also see David Schiff, *The Music of Elliott Carter*, 26.

⁴⁰See Bernard's discussion of the *Cello Sonata* in "Elliott Carter's Rhythmic Practice," 167-174.

Example 2.2 - Triple Duo, mm. 4-8.

4

Agitato
in tempo ($\text{♩} = 100$)

Fl.

B^b Cl.

Perc. (SD)

Pno. Piano solo to end of 16

Vln.

Vcl.

7 ($\text{♩} = 100$)

Temple Blocks TB3

SD

Pno. (marc. sempre) *mf* *leggero* (*mf*)

Vln. pizz. *mp* arco *mp* *pp* *mp* *p* *mp* *p* *mp*

Vcl. pizz. *mp* (pizz.) *p* *mp* *p* *mp* *p* *mp*

Of course the strategy outlined above requires a judicious choice of beat divisions. If the beat divisions of two or more layers were the same or were whole number multiples of one another (eighths and sixteenths say) then the rhythmic individualization of the layers would be attenuated, since the surface rhythms of different layers would all align with the pulses of a single grid.

While the presence of beat divisions that are whole-number multiples of one another does not necessarily prohibit the rhythmic independence of the layers (cf. any fugue by Bach), it does create a sense of rhythmic homogeneity that Carter generally avoids in his recent works.⁴¹ He does so by minimizing the coincidence of pulses from the grids of different layers. If the beat divisions of two layers share a common factor of 'n', then pulses from their corresponding pulse grids will coincide 'n' times per notated beat. Thus to minimize the number of coincident pulses one must minimize the common factors in the beat divisions.

Carter achieves this goal with remarkable elegance first by assigning one stream of a long-range polyrhythm to each layer of a composition, then by using the beat divisions in which a layer's pulsations can be notated accurately also to determine the layer's pulse grid. This method accomplishes two of Carter's compositional aims: it facilitates the formation of pulse grids with minimal common factors (thus ensuring a more flexible and varied surface rhythm), and it provides a clear connection between the rhythmic surface and the long-range polyrhythmic plan of the composition as a whole.

⁴¹Carter has said that his interest in long-range polyrhythms comes partly from "the idea that one is sort of destroying the constant regular metric pattern that runs through most music of the past." (Interview with the author, 8/31/92.)

To see how this works, recall that the range of beat divisions capable of expressing pulsations can be calculated with the formula for the number of beats between pulsations. This formula is reproduced in figure 2.1.

Figure 2.1 - The formula for the number of beats between pulsations.

$$\text{Number of beats between pulsations (B)} = \frac{T_n \times C_n}{T_d \times C_d \times P}$$

In the previous chapter we found that once the fraction in figure 2.1 is reduced to lowest terms, the denominator gives the level of beat division required to notate a pulsation accurately. As discussed above, the same beat division also generates the given stream's pulse grid. Each stream will have a different value for the denominator of the formula, since each stream has a different pulsation total (P). The value also will change depending on the notated tempo $\frac{T_n}{T_d}$.⁴² But whatever its exact value, the number indicating beat division will always be a factor of the stream's pulsation total (P) and/or the denominators of the notated tempo and the cyclic duration (T_d and C_d).

Figure 2.2 gives an example in which the number of beats between pulsations of both streams of the *Night Fantasies* polyrhythm is calculated at a tempo of ♩ = 126. (Recall that the cyclic duration of *Night Fantasies* is 20

⁴²As before, the subscripts 'n' and 'd' simply stand for "numerator" and "denominator." This notation is useful in dealing with the fractional tempo markings that often arise in Carter's recent music.

minutes.) In this case T_D and C_D are both equal to one, so the number-of-beats-between-pulsations formula simplifies to $\frac{T \times C}{P}$.

Figure 2.2 - Calculating the number of notated beats between pulsations of the Night Fantasies polyrhythm at a tempo of $\downarrow = 126$.

$$\text{Slow stream: } B = \frac{T \times C}{P} = \frac{126 \times 20}{175} = \frac{72}{5} = 14\frac{2}{5} \text{ beats}$$

$$\text{Fast stream: } B = \frac{T \times C}{P} = \frac{126 \times 20}{216} = \frac{35}{3} = 11\frac{2}{3} \text{ beats}$$

Note that in figure 2.2 the beat divisions of both streams are factors of their respective pulsation totals (five is a factor of 175 and three is a factor of 216). Since the polyrhythm of *Night Fantasies* has no partial coincidence points, the pulsation totals share no non-trivial common factors, and therefore the beat divisions that generate the pulse grids share no common factors either. In this case, the desired result of minimizing the coincidence of pulses from different grids (and hence maximizing the rhythmic independence of the layers) is facilitated by the properties inherent in the long-range polyrhythm.

The situation is somewhat different for polyrhythms involving fractional tempi (T_D) and/or a fractional cyclic duration (C_D). Because these values are the same for all streams, they introduce common factors into the beat division formulas that could limit the rhythmic independence of the layers. In Carter's 1984 duet *Esprit Rude/Esprit Doux*, for example, there are

two streams, with pulsation totals of 21 for the flute and 25 for the clarinet, and the cyclic duration is $4\frac{2}{3}$ or $\frac{14}{3}$ minutes. Here the value of C_d is three, which becomes a common factor in the denominators of the beat division formulas, given in figure 2.3.

Figure 2.3 - Beat division formulas for Esprit Rude/Esprit Doux.

$$\begin{aligned} \text{flute:} \quad B &= \frac{T \times C}{P} = \frac{T \times \frac{14}{3}}{21} = \frac{T \times 14}{21 \times 3} = \frac{T \times 2}{3^2} \\ \text{clarinet:} \quad B &= \frac{T \times C}{P} = \frac{T \times \frac{14}{3}}{25} = \frac{T \times 14}{25 \times 3} = \frac{T \times 14}{5^2 \times 3} \end{aligned}$$

At a tempo of, say, 100 the values of the equations would be $\frac{200}{9}$ and $\frac{56}{3}$ respectively. Their denominators (and thus their corresponding pulse grids) would share the common factor of three introduced by C_d . In order to avoid the common factor Carter uses only tempi with T_n values that contain a factor of three. The threes in the numerator and denominator then cancel, eliminating the common factor.

The polyrhythm of the Oboe Concerto (1987) consists of two streams, one for the oboe and its concertino (with a pulsation total of 63), and one for the orchestra (with a pulsation total of 80). In this case a potential common factor arises from Carter's use of fractional *tempi* with denominator values of three.⁴³ To eliminate the common factor, Carter made the cyclic duration of

the piece 18 minutes (see figure 2.4). As a result, the factors in the denominators of the beat division formulas remain unique to each stream.

Figure 2.4 - Beat divisions in the Oboe Concerto for fractional tempi with a denominator value of three.

$$\begin{aligned} \text{ochoe:} \quad B &= \frac{T_n \times C}{T_d \times P} = \frac{T_n \times 18}{3 \times 63} = \frac{T_n \times 6}{63} = \frac{T_n \times 2}{3 \times 7} \\ \text{orchestra:} \quad B &= \frac{T_n \times C}{T_d \times P} = \frac{T_n \times 18}{3 \times 80} = \frac{T_n \times 6}{80} = \frac{T_n \times 3}{2^3 \times 5} \end{aligned}$$

The examples given above are typical of Carter's handling of fractional tempi and cyclic durations. A factor in the denominator of one is invariably cancelled by the occurrence of the same factor in the numerator of the other. This means that for polyrhythms without partial coincidence points, the available beat divisions are always factors of their respective streams' pulsation totals, and thus they share no common factors with each other.

In choosing his beat divisions Carter also must contend with a more practical matter: they must be manageable for the performers. The difficulty of a beat division is partly a function of its fineness. The larger the denominator value of the number-of-beats-between-pulsations formula, the finer a beat must be divided in order to express a pulsation. But particularly at slow tempi, large values of the denominator are not overly difficult, provided they

⁴³In his works after *Night Fantasies* Carter usually avoids fractional or decimal tempo indications in his scores, preferring an approximate notation instead. The first fractional tempo in the Oboe Concerto is $93\frac{1}{3}$, at m. 60, which Carter abbreviates 93^+ . The exact values usually can be inferred from the tempo modulations, and often appear in Carter's sketches.

are divisible into relatively small factors. A beat division of 16, for example, is entirely feasible at a slow tempo, since it is easy to subdivide 16 into smaller groups of two, four, or eight. A beat division of 13, on the other hand, is much more difficult. Though smaller, 13 is a prime number and thus cannot be subdivided.⁴⁴ These considerations have led Carter to limit the size of the prime factors he uses in the beat divisions of his works since 1980. In the chamber works he uses only beat divisions with factors of 2, 3, 5, and 7. In his orchestral music, Carter favors beat divisions with factors of 2, 3, and 5.⁴⁵

One way to avoid beat divisions with large factors is to omit prime factors greater than seven from the pulsation totals and the denominators of the tempi and cyclic duration. This is Carter's strategy in a number of his recent works, such as *Night Fantasies*, *Enchanted Preludes*, and *Esprit Rude/Esprit Doux*.⁴⁶ If the pulsation totals contain larger factors, then they must be cancelled from the denominator of the beat division formula by also occurring in the numerator, as factors of the tempo or cyclic duration. In *Triple Duo*, for example, Carter wanted a polyrhythm of three streams, one for each of the three pairs of instruments (flute/clarinet, piano/percussion, and violin/cello) into which the ensemble is divided. He chose a cyclic duration of twenty minutes, and pulsation totals of 33 (for the woodwinds), 65 (for the piano and percussion), and 56 (for the strings).⁴⁷ Because the work

⁴⁴See Charles Rosen, "One Easy Piece," 24.

⁴⁵Occasionally Carter will write septuplets in an orchestral work. Usually such passages involve a solo instrument or other situation in which the more complicated beat division is restricted to a relatively small group of instruments. The most notable case is the abundant septuplets after m. 199 in the oboe and concertino parts of the Oboe Concerto. Another example is the piano part in *Penthode*, mm. 262-264.

⁴⁶See the listings for these pieces in the appendix.

⁴⁷But see below for a discussion of the cut in the *Triple Duo* polyrhythm.

was written for the Fires of London, to be played without a conductor, Carter limited his choice of beat divisions to factors of 2, 3, and 5. The formulas for the number of beats between pulsations in *Triple Duo* are given in figure 2.5.

Figure 2.5 - The number of beats between pulsations in *Triple Duo*.

$$\text{flute/clarinet: } B = \frac{T \times C}{P} = T \times \frac{20}{33}$$

$$\text{piano/percussion: } B = \frac{T \times C}{P} = \frac{T \times 20}{65} = T \times \frac{4}{13}$$

$$\text{violin/cello: } B = \frac{T \times C}{P} = \frac{T \times 20}{56} = T \times \frac{5}{14}$$

Because the denominators of these equations contain factors of 11, 13, and 7 respectively, and since the cyclic duration is a whole number, the three primes must all be factors of the notated tempo if they are to be canceled as factors of the beat divisions. The slowest tempo that would accomplish this is $7 \times 11 \times 13$, or 1001, clearly too fast to be feasible. Instead Carter chose a fractional basic tempo of $\frac{1001}{10}$ or 100.1. (See figure 2.6.)

Figure 2.6 - The number of beats between pulsations in Triple Duo.

$$\text{flute/clarinet: } B = T \times \frac{20}{33} = \frac{1001}{10} \times \frac{20}{33} = \frac{182}{3} = 60\frac{2}{3} \text{ beats}$$

$$\text{piano/percussion: } B = T \times \frac{4}{13} = \frac{1001}{10} \times \frac{4}{13} = \frac{154}{5} = 30\frac{4}{5} \text{ beats}$$

$$\text{violin/cello: } B = T \times \frac{5}{14} = \frac{1001}{10} \times \frac{5}{14} = \frac{142}{4} = 35\frac{3}{4} \text{ beats}$$

The 1001 in the numerator cancels the undesirable factors in all three of the pulsation totals, and the 10 in the denominator gives the piano and percussion their five-part beat division and contributes a factor of 2 to the violin and cello's beat division of four. As a result, Carter achieves unique beat divisions for each stream that are both manageable for the performers and share no common factors.⁴⁸

Another strategy Carter has used to eliminate overly-complex beat divisions is illustrated by a passage from *Night Fantasies* written at a tempo of $\downarrow = 54$. The number of beats between pulsations of the slow stream at that tempo is given in Figure 2.7.

⁴⁸In writing the score Carter rounded off the 100.1 tempo to an even 100. This slight decrease in the tempo is balanced by a slight increase in the cyclic duration, and the the number of beats between pulsations does not change. The 100.1 tempo is found on several of Carter's sketches for *Triple Duo*, in the Elliott Carter Collection of the Paul Sacher Foundation.

Figure 2.7 - The number of beats between pulsations of the slow stream in Night Fantasies at a tempo of $\text{♩} = 54$.

$$B = \frac{T \times C}{P} = \frac{54 \times 20}{175} = \frac{54 \times 4}{35} = \frac{216}{35}$$

From the formula in figure 2.7 it appears that a beat division of 35 is required to notate pulsations accurately, but in this case Carter simply regroups the number of beats required as shown in Figure 2.8.

Figure 2.8 - Regrouping the number of beats between pulsations.

$$B = \frac{216}{35} = \frac{196}{35} + \frac{20}{35} = 5\frac{3}{5} + \frac{4}{7}$$

The musical result is given in example 2.3.

Example 2.3 - *Night Fantasies*, mm. 135 - 140.

♩ = 54

135

f *legato, chiaro*

poco PEDALE

138

mp *legato*

poco cresc. [*f*]

sub.

The pulsation X_{50} occurs on the third eighth-note quintuplet of m. 137. The $1\frac{3}{5}$ beats remaining in that measure, plus two beats for m. 138 and two beats for m. 139 equals $5\frac{3}{5}$ beats, to which the first $\frac{4}{7}$ of beat 1 of m. 140 are added to complete the time before the next pulsation, X_{51} .

The above approach to complex beat divisions is problematic for two reasons. First, it is not always possible. Had pulsation X_{50} in example 2.3 occurred on a notated beat, a beat division of 35 would have been required to notate pulsation X_{51} accurately.⁴⁹ Second, the use of different beat divisions within a single stream runs counter to one of Carter's central rhythmic strategies: the dramatic juxtaposition of polyrhythmic streams. Example 2.3 is one of the rare occasions in *Night Fantasies* when the beat divisions involved in a surface polyrhythm (5 against 7 in mm. 135 ff.) arise from a single stream. (Notice that 5 and 7 are divisions available only to the slow stream.) In order to emphasize the disruption of his strategy, Carter gives the passage in example 2.3 special emphasis by means of sudden changes in articulation, dynamics, and register on the downbeat of m. 136.

In two of his works from the mid-1980s, *Penthode* (1985) and *String Quartet No. 4* (1986), Carter has used polyrhythms that are somewhat more elaborate than those of his other recent works. Both involve a larger number of streams than usual, and both make use of partial coincidence points.

The polyrhythm of *String Quartet No. 4* has four streams, one for each of the instruments. The first violin plays 120 pulsations to the second violin's 126, the viola's 175, and the cello's 98. Recall that partial coincidence points

⁴⁹Perhaps for this reason the excerpt in example 2.3 is Carter's only use of a tempo of 54 in *Night Fantasies*.

occur when the pulsation totals of two or more streams share a common factor greater than one; if the common factor is 'n', the streams coincide 'n' times per cycle. The prime factorizations of the pulsation totals for String Quartet No. 4 are given in figure 2.9.

Figure 2.9 - Prime factorizations of the pulsation totals in String Quartet No. 4.

$$\begin{array}{ll} \text{Violin I: } P = 120 = 2^3 \times 3 \times 5 & \text{Violin II: } P = 126 = 2 \times 3^2 \times 7 \\ \text{Viola: } P = 175 = 5^2 \times 7 & \text{Cello: } P = 98 = 2 \times 7^2 \end{array}$$

Figure 2.9 shows that there are common factors among the pulsation totals of two or three of the instruments, but none common to all four. Thus 120:126:175:98 is a single cycle of a polyrhythm, although pairs and trios of instruments coincide at various times along the way.

Assigning each instrument its own unique beat division is complicated in this case by the common factors among the pulsation totals. The violins and cello share a factor of two, the violins share a factor of three, the first violin and viola share a factor of five, and the second violin, viola, and cello share a factor of seven. Each of these factors — two, three, five, and seven — would have to be cancelled from the denominator of the beat division formulas or the beat divisions of some instruments would share a common factor. Most of the common factors are eliminated by the cyclic duration, which is $23\frac{1}{3}$ or $\frac{70}{3}$ minutes. The numerator of the cyclic duration, $70 = 2 \times 5 \times 7$, cancels all of the common factors in the denominator except the three,

shared by the two violins. The denominator of the cyclic duration, on the other hand, *adds* a factor of three to the potential beat divisions of all the instruments, yielding the beat division formulas given in figure 2.10.

Figure 2.10 - Beat division formulas for String Quartet No. 4.

$$\text{Violin I: } B = \frac{T \times C_n}{C_d \times P} = \frac{T \times 70}{3 \times 120} = T \times \frac{7}{2^2 \times 3^2}$$

$$\text{Violin II: } B = \frac{T \times C_n}{C_d \times P} = \frac{T \times 70}{3 \times 126} = T \times \frac{5}{3^3}$$

$$\text{Viola: } B = \frac{T \times C_n}{C_d \times P} = \frac{T \times 70}{3 \times 175} = T \times \frac{2}{3 \times 5}$$

$$\text{Cello: } B = \frac{T \times C_n}{C_d \times P} = \frac{T \times 70}{3 \times 98} = T \times \frac{5}{3 \times 7}$$

In order to cancel the two factors of three from the beat division formulas, Carter most often uses whole-numbered tempi that are multiples of nine. Figure 2.11 gives the beat division formulas for the four instruments at tempi of $T = 9t$, that is where the tempo is a multiple of nine.

Figure 2.11 - Beat division formulas for String Quartet No. 4.

$$\text{Violin I: } B = T \times \frac{7}{2^2 \times 3^2} = 9t \times \frac{7}{2^2 \times 3^2} = \frac{t \times 7}{4}$$

$$\text{Violin II: } B = T \times \frac{5}{3^3} = 9t \times \frac{5}{3^3} = \frac{t \times 5}{3}$$

$$\text{Viola: } B = T \times \frac{2}{3 \times 5} = 9t \times \frac{2}{3 \times 5} = \frac{t \times 6}{5}$$

$$\text{Cello: } B = T \times \frac{5}{3 \times 7} = 9t \times \frac{5}{3 \times 7} = \frac{t \times 15}{7}$$

The formulas in figure 2.11 appear to give each instrument a unique beat division. But if the value of 't' matches the denominator of an instrument's formula then the instrument's pulsations will occur *on* a notated beat. At a tempo of 45 (= 9 x 5) for example, 't = 5, and the viola's pulsations will occur on every sixth notated beat. In such cases, Carter generally preserves the beat divisions suggested by the denominators in figure 2.11, even though the accurate notation of pulsations does not require it.⁵⁰ Brief exceptions occur when an instrument articulates a tempo modulation. In m. 128 for example, the first violin briefly breaks into septuplets in order to cue the tempo modulation at m. 129 (See example 2.4).

⁵⁰The tempo 45, for example, is used in mm. 344-358, during which the viola maintains its characteristic quintuplet beat division.

Example 2.4 - String Quartet No. 4, mm. 127-130.

The image displays a musical score for a string quartet, consisting of two systems of four staves each. The first system covers measures 127 to 130, and the second system covers measures 131 to 134. The score includes various musical notations such as notes, rests, and dynamic markings.

System 1 (Measures 127-130):

- Measure 127: Tempo marking $\text{♩} = 72$. First staff has a pp dynamic. Second staff has a *senza sord.* marking.
- Measure 128: First staff has a pp dynamic. Second staff has a p dynamic.
- Measure 129: First staff has a pp dynamic. Second staff has a p dynamic. A X_{15} marking is present above the first staff.
- Measure 130: First staff has a pp dynamic. Second staff has a p dynamic. A F dynamic marking is present above the first staff.

System 2 (Measures 131-134):

- Measure 131: Tempo marking $\text{♩} = 63$. First staff has a pp dynamic. Second staff has a p dynamic. A Q_{32} marking is present above the first staff.
- Measure 132: First staff has a pp dynamic. Second staff has a p dynamic. A f marc. marking is present above the second staff.
- Measure 133: First staff has a pp dynamic. Second staff has a p dynamic. A f marc. marking is present above the second staff. A X_{51} marking is present above the third staff.
- Measure 134: First staff has a pp dynamic. Second staff has a p dynamic. A f marc. marking is present above the second staff. A Q_{24} marking is present above the first staff.

So far, Carter's polyrhythmic practice in String Quartet No. 4 is similar to that of previous examples. But there are significant departures at tempi of 63 and 84, which are the two most frequently used tempi in the piece.

At a tempo of 63 the first violin's pulsations occur every $12\frac{1}{4}$ beats, and the first violin consistently plays beat divisions that are multiples of two. The cello's pulsations occur every 15 beats, on a notated beat, but in addition to its characteristic septuplet beat division, the cello frequently plays the same multiples-of-two beat divisions used by the first violin. During such passages Carter is careful to avoid simultaneous attacks in the two instruments. He keeps them out of each other's way either by treating them antiphonally, as in mm. 134-144, or by sharply contrasting their rhythmic behavior, as in mm. 41-62, when the first violin's sweeping accelerando and ritard is juxtaposed against the cello's more regular music.

The longest passage written at a tempo of 63 starts in m. 191 and continues until m. 312.⁵¹ The first part of this passage (mm. 191-213) is the conclusion of the *Scherzando* section. In this passage the cello plays septuplet beat divisions, except during the two measures following the tempo modulation at m. 191. The *Lento*, marked at m. 214, actually begins one beat earlier with the coincidence of pulsations from the streams of the two violins and the cello. This partial coincidence point heralds a change of beat division for the cello, which now takes up (for the remainder of the *Lento*) the same multiples-of-two beat divisions used by the first violin.

⁵¹The tempo of ♩ = 63 shifts briefly to ♩ = 42 when the meter changes from simple to compound in mm. 247-249.

The beat divisions for the four instruments at a tempo of 84 are given in figure 2.12.

Figure 2.12 - Beat division formulas for String Quartet No. 4 at a tempo of 84.

$$\text{Violin I: } B = T \times \frac{7}{2^2 \times 3^2} = \frac{84 \times 7}{2^2 \times 3^2} = \frac{49}{3}$$

$$\text{Violin II: } B = T \times \frac{5}{3^3} = \frac{84 \times 5}{3^3} = \frac{140}{9}$$

$$\text{Viola: } B = T \times \frac{2}{3 \times 5} = \frac{84 \times 2}{3 \times 5} = \frac{56}{5}$$

$$\text{Cello: } B = T \times \frac{5}{3 \times 7} = \frac{84 \times 5}{3 \times 7} = 20$$

Note that in this case the factor of three common to the pulsation totals of the two violins has not been cancelled, and remains a factor of the beat divisions of both instruments. Carter compensates for the common factor by allowing the first violin considerable freedom to depart from its three-part beat division in passages written at a tempo of 84. Significantly, the departures always involve beat divisions that are multiples of two, divisions not shared by the other instruments at that tempo. At tempi other than 84, the first violin returns to a single-factor pulse grid.

In his program note to String Quartet No. 4 Carter writes of wanting the music to mirror "the democratic attitude in which each member of a

society maintains his or her own identity while cooperating in a common effort..." and that "more than in others of my scores, a spirit of cooperation prevails."⁵² The common effort that Carter mentions is reflected in the piece in a number of ways, from the many shared gestures to the somewhat traditional four-movement plan of the work as a whole. It also finds elegant expression in Carter's choice of a polyrhythm with partial coincidence points.

For a number of reasons *Penthode* (1985), for five groups of four instrumentalists, is unique among Carter's polyrhythmic compositions. Like String Quartet No. 4 it uses a polyrhythm with partial coincidence points, but it has five streams (one for each instrumental group), the largest number of streams Carter has used to date. It is also the only one of the composer's recent works to be based on an out-of-phase polyrhythm, the only one in which the cyclic duration significantly exceeds the length of the composition, and the only one in which the same beat divisions are shared throughout by two or more streams.

The scope of the *Penthode* polyrhythm is truly enormous; if all five streams began together, a single cycle would last $453,786\frac{2}{3}$ minutes, or around 315 days! Needless to say, Carter chose to use only a short segment of a cycle in the actual composition. The pulsation totals for the *Penthode* polyrhythm are given in figure 2.13.

⁵²Carter's program note to the score of String Quartet No. 4 (Boosey and Hawkes HPS-1130).

Figure 2.13 - Pulsation totals of the Penthode polyrhythm.

$$\text{Group 1: } 2,079,168 = 2^6 \times 3 \times 7^2 \times 13 \times 17$$

$$\text{Group 2: } 1,786,785 = 3 \times 5 \times 7^2 \times 11 \times 13 \times 17$$

$$\text{Group 3: } 1,944,800 = 2^5 \times 5^2 \times 11 \times 13 \times 17$$

$$\text{Group 4: } 1,832,600 = 2^3 \times 5^2 \times 7^2 \times 11 \times 17$$

$$\text{Group 5: } 1,793,792 = 2^8 \times 7^2 \times 11 \times 13$$

The polyrhythmic streams of groups three, four, and five are all in phase with one another; that is, all three would eventually coincide. Considered by themselves, streams three, four, and five form a polyrhythm with pulsation totals 22,100 ($2^2 \times 5^2 \times 13 \times 17$), 20,825 ($5^2 \times 7^2 \times 17$), and 20,384 ($2^5 \times 7^2 \times 13$) respectively. The pulsation totals of streams three and four share a greatest common factor of 425, so these streams coincide 425 times per cycle. Similarly, streams four and five coincide 49 times per cycle, and streams three and five, 52 times per cycle. The polyrhythm formed by streams three, four, and five alone repeats 88 times per cycle of the polyrhythm formed by all five streams together.

The streams associated with groups one and two are in phase with each other but out of phase with the streams of the other three groups. Together streams one and two form a polyrhythm of 64:55, which repeats 32,487 times per cycle of the global polyrhythm. Considering the five-stream polyrhythm as a whole, there would eventually be partial coincidence points between all pairs of streams except one and five, two and three, and two and four.

Near the beginning of the piece there is a certain degree of ambiguity in the placement of pulsations in streams three and five. The opening measures of *Penthode* are given in example 2.5.

The piece begins with an extended solo for viola, "tranquillo, quasi improvisando, un poco espressivo." The rubato line in the viola is punctuated by prominent multiple stops in m. 2, m. 7, and m. 13 (the Db5-Bb5 dyad). These articulations are equally spaced $21\frac{1}{4}$ beats apart, and seem to indicate the first three pulsations of stream five, but after m. 13 these pulsations disappear, and the viola, starting on beat three of m. 15, joins the other instruments of group five in articulating another stream of pulsations (also $21\frac{1}{4}$ beats apart) that began with the piano chord in m. 4, and this stream continues throughout the remainder of the work.

There is a similar ambiguity in stream three. There are hints of a stream of pulsations beginning on beat four of m. 5 (the first utterance by group 3 in the piece) and continuing on the fourth quintuplet sixteenth of beat three in m. 10, but this also proves to be a false start, and the true stream begins with the tuba/violin/cello chord in m. 6. Had Carter continued the "false start" streams associated with groups three and five, streams one and five would have been out of phase, as would streams three and four.

Example 2.5 - *Penthode*, mm. 1-15.

PENTHODE

♩ = 66, scurrerole ma tranquillo Elliott Carter
(1985)

1 Tpt. (1) (in C) *whisper mute*
Tbn. *whisper mute*
Hp. *pp*
Vla. (1) *pp*

4
4

5 Perc. *pp*
Vla. *tranne que impressada, se para e se*
mf *para p* *(sempre para)*

⑤

1 Tpt. (1)
Tbn.
Hp.
Vla. (1)

2 Picc. *pp*
Mn. (in F) *wood mute* *pp*
Ch. *pp*

3 E.H. (in F)
Tbn. *pp*
Vla. (2) *pp*
Vc. *pp*

5 Bsn.
Vla. *pp*

© Copyright 1985 by Mendon Music, Inc.,
a Boosey & Hawkes company
Copyright for all countries. All rights reserved.

P28 481

Printed in U.S.A. 1989

1 Tpt. (I) straight cardboard mute

Tbn. straight cardboard mute

Hp.

Vln. (I)

2 Flc. Poco to F

Hn. cardboard mute

Mar. soft sticks

Cb. (run over)

3 E. H.

Tba. mufe

Vln. (2) (run over)

Vc. (run over)

4 Cl. (in Bb)

Bb. Cl. (in Bb)

Tpt. (II) (in C) softer soft sticks

Vib.

5 Bsn.

Fag.

Perc. (D)

Vln. (II)

PSB 45

(15)

1 Tpt. (1)
Tba.
Hp.
Vla. (1)

2 Fl.
Hn.
Mar.
Ch.

3 E. H.
Tba.
Vla. (2)
Vc.

4 Cl.
B♭ Cl.
Tpt. (2)
Vib.

5 Ban.
Psa.
Perc. (2)
Vla.

straight muted notes

(comp. viola)

750 441

During the segment of the polyrhythm heard in *Penthode* there are three partial coincidence points: streams one and two coincide in m. 241 on the third triplet eighth of beat four; streams three and four on the downbeat of m. 266; and streams four and five on the downbeat of m. 437. The coincidence of streams three and four in m. 266 occurs on the 356th partial coincidence point of the polyrhythm formed by streams three, four, and five alone. (It is the 18,461st pulsation of stream three, and the 17,396th pulsation of stream four.) The coincidence of streams four and five in m. 437 is their 42nd of the cycle (pulsation 17,426 of stream four and pulsation 17,057 of stream five). The piece begins just prior to the first pulsation in stream one, which occurs on the the third beat of m. 4. This is roughly $\frac{3}{10}$ of the way through a cycle of the 64:55 polyrhythm played by groups one and two, and $\frac{5}{6}$ of the way through the polyrhythm formed by streams three, four, and five.

Because the polyrhythm in *Penthode* has five streams, Carter handles the assignment of beat divisions somewhat differently in this work. In order to ensure no common factors among the beat divisions, he would have had to use at least five different prime factors, the smallest of which are 2, 3, 5, 7, and 11. Given the choice between sharing factors among the beat divisions, and writing beat divisions with factors of 11 or greater, Carter chose the former, as would, I believe, the vast majority of orchestral musicians. The pulsation totals and cyclic duration of the *Penthode* polyrhythm produce the beat division formulas given in figure 2.14.

Figure 2.14 - Beat division formulas for the Penthode *polyrhythm*.

$$\text{Group 1: } B = \frac{T \times C_n}{C_d \times P} = \frac{T \times (2^4 \times 5 \times 7 \times 11 \times 13 \times 17)}{3 \times (2^6 \times 3 \times 7^2 \times 13 \times 17)} = \frac{T \times 5 \times 11}{2^2 \times 3^2 \times 7}$$

$$\text{Group 2: } B = \frac{T \times C_n}{C_d \times P} = \frac{T \times (2^4 \times 5 \times 7 \times 11 \times 13 \times 17)}{3 \times (5 \times 7^2 \times 11 \times 13 \times 17)} = \frac{T \times 2^4}{3 \times 7}$$

$$\text{Group 3: } B = \frac{T \times C_n}{C_d \times P} = \frac{T \times (2^4 \times 5 \times 7 \times 11 \times 13 \times 17)}{3 \times (2^5 \times 5^2 \times 11 \times 13 \times 17)} = \frac{T \times 7}{2 \times 3 \times 5}$$

$$\text{Group 4: } B = \frac{T \times C_n}{C_d \times P} = \frac{T \times (2^4 \times 5 \times 7 \times 11 \times 13 \times 17)}{3 \times (2^3 \times 5^2 \times 7^2 \times 11 \times 17)} = \frac{T \times 2 \times 13}{3 \times 5 \times 7}$$

$$\text{Group 5: } B = \frac{T \times C_n}{C_d \times P} = \frac{T \times (2^4 \times 5 \times 7 \times 11 \times 13 \times 17)}{3 \times (2^8 \times 7^2 \times 11 \times 13)} = \frac{T \times 5 \times 17}{2^4 \times 3 \times 7}$$

In order to avoid beat divisions of seven, Carter uses only whole-number tempi with a factor of seven. The most frequently used tempo is $\text{♩} = 84 (2^2 \times 3^2 \times 7)$, which produces the numbers of beats between pulsations for each stream shown in figure 2.15.

Figure 2.15 - Beat division formulas for the *Penthode* polyrhythm at a tempo of $\text{♩} = 84$.

$$\text{Group 1: } B = \frac{T \times 5 \times 11}{2^2 \times 3^2 \times 7} = \frac{(2^2 \times 3 \times 7) \times 5 \times 11}{2^2 \times 3^2 \times 7} = \frac{55}{3}$$

$$\text{Group 2: } B = \frac{T \times 2^4}{3 \times 7} = \frac{(2^2 \times 3 \times 7) \times 2^4}{3 \times 7} = \frac{64}{3}$$

$$\text{Group 3: } B = \frac{T \times 7}{2 \times 3 \times 5} = \frac{(2^2 \times 3 \times 7) \times 7}{2 \times 3 \times 5} = \frac{98}{5}$$

$$\text{Group 4: } B = \frac{T \times 2 \times 13}{3 \times 5 \times 7} = \frac{(2^2 \times 3 \times 7) \times 2 \times 13}{3 \times 5 \times 7} = \frac{104}{5}$$

$$\text{Group 5: } B = \frac{T \times 5 \times 17}{2^4 \times 3 \times 7} = \frac{(2^2 \times 3 \times 7) \times 5 \times 17}{2^4 \times 3 \times 7} = \frac{85}{4}$$

Figure 2.15 reveals that not only do the beat divisions of some instrumental groups share common factors, some are exactly the same. Carter exploits this feature of the polyrhythm by frequently blurring the distinctions among the instrumental groups. Instruments from different groups that are members of the same family often combine in short sections, such as the soli for woodwinds in mm. 160-163 (not shown), and pulsations belonging to one group are frequently reinforced by instruments from the others, most notably in the final minute of the piece.

Carter's rhythmic practice in *Penthode* is an elegant expression of the "experiences of connectedness and isolation" with which the composer is

concerned in this piece.⁵³ There is rhythmic isolation in that the five streams never all coincide, and connectedness in the occasional pairwise coincidence points, and, more directly, in the shared beat divisions, and the pulsations reinforced by instruments from different groups. The arrangement of the instruments further emphasizes the polarity of isolation/connectedness. Within each group the instruments are often diverse in the extreme, but they are connected by the short soli for instruments from the same family. Further connection is made by means of an extended melody passed from instrument to instrument and group to group during the first and last sections of the piece.

⁵³Carter's program note to the score of *Penthode* (Boosey & Hawkes FSB 481).

Chapter 3 — Analytical and Perceptual Issues

So far I have not addressed the question of how long-range polyrhythms can affect our hearing of Carter's recent music. In most of his pieces the slow speed of the pulsations and the generally thick textures present significant obstacles to perceptibility. One might reasonably ask: what good is an analysis of long-range polyrhythms, much less a theoretical discussion of their abstract properties, if a listener is unlikely to experience the regularity of the pulsations? The examples that follow provide some answers to this question, and demonstrate the analytical value of long-range polyrhythms. Though often obscured by much faster rhythmic activity, Carter's polyrhythms are not simply a numerical game; they leave their mark on his compositions in a number of musically palpable ways.

PULSATIONS IN ISOLATION

The most direct way Carter emphasizes the pulsations of a long-range polyrhythm is by presenting them in isolation, as in the *tranquillo* section of *Esprit Rude/Esprit Doux* in example 3.1. Here, long sustained notes change pitch only on pulsations of the underlying polyrhythm. True to form, Carter avoids absolute regularity, introducing irregularly-placed repeated notes in both instruments: the flute repeats C₆ in m. 56, three-fifths of the way between its fourteenth and fifteenth pulsations, while the clarinet repeats a written F₆ in m. 59, three-sevenths of the way between its eighteenth and nineteenth pulsations.

Example 3.1 - *Esprit Rude/Esprit Doux*, mm. 50-61.

The musical score consists of three systems of staves, each with a treble and bass clef. The first system (mm. 50-53) features a treble staff with notes and rests, and a bass staff with a long note. Annotations include *O₁₃ tranquillo* above the treble staff, *X₁₅ tranquillo* above the bass staff, and *p* and *poco* dynamics. The second system (mm. 54-57) has a treble staff with a melodic line and a bass staff with a long note. Annotations include *O₁₄* and *O₁₅* above the treble staff, *X₁₇* above the bass staff, and *poco* dynamics. The third system (mm. 58-61) has a treble staff with notes and rests, and a bass staff with a long note. Annotations include *O₁₆* above the treble staff, *X₁₈* and *X₁₉* above the bass staff, and *pp* dynamics. Various musical notations such as slurs, ties, and fingerings (e.g., 3, 5) are present throughout the score.

PULSATIONS AND LOCAL POLYRHYTHMS

The pulsations of Carter's long-range polyrhythms also can be reflected on the rhythmic surface of a composition when combined with faster, local polyrhythms (see example 3.2). Here the pulsations of both the fast stream (marked with 'O's) and the slow stream (marked with 'X's) are articulated by forte staccato notes, which jump out from the surrounding texture of soft chords.

The influence of the underlying polyrhythm is also heard in the duration of this passage, which is determined by one proximity cycle.⁵⁴ The first accented staccato attacks in m. 419 articulate a span of maximum convergence. Successive attacks are further and further apart up to the region of maximum divergence that spans pulsations $O_{177} - X_{144} - O_{178}$, then they begin to move closer together again, reaching the next span of maximum convergence beginning on the downbeat of m. 434 (not shown).

The accompanying chords in these measures articulate the pulsations of a local polyrhythm of 81:80. These pulsations are also numbered in example 3.2. Since the difference between the local pulsation totals is one, the polyrhythm 81:80 contains only one proximity cycle, with a single span of maximum convergence at the coincidence point and a single region of maximum divergence centered on the midpoint — pulsation 41 of the slow stream. The first pulsation to be articulated is number 46 of the fast stream on the downbeat of m. 417. The passage thus contrasts the convergence and divergence of one proximity cycle of the long-range polyrhythm, with the

⁵⁴See the discussion of proximity cycles in chapter 1.

continuous convergence of the slow chords, articulating the second half of the local polyrhythm's proximity cycle.

The passage in example 3.2 also contains an anomaly in the long-range polyrhythm. Beginning in m. 419 pulsations in both streams come one sixteenth note late. Carter probably made this adjustment to avoid the coincidence on the downbeat of m. 425 of pulsation 52 in the right hand's stream of the local polyrhythm, and the long-range polyrhythm's pulsation O_{177} . Other examples of anomalies in Carter's long-range polyrhythms will be given below.

Local and long-range polyrhythms are also combined in mm. 41-54 of *Night Fantasies*. Example 3.3 is an analytic arrangement of this passage, with the streams of the local polyrhythm notated in the upper system, and those of the long-range polyrhythm in the lower system. Here Carter combines pulsations O_{24} - O_{27} and X_{20} - X_{22} of the long-range polyrhythm with pulsations of a local polyrhythm of $12t:125$. The local polyrhythm articulates a sequence of mostly four-note chords, certain notes of which are emphasized by pulsations of the long-range polyrhythm. Once again the local pulsation totals differ by one so there is a single proximity cycle, with a span of maximum convergence at the coincidence point, and a region of maximum divergence centered on the midpoint.

Carter begins the local polyrhythm just prior to its halfway point, as the pulsations approach the region of maximum divergence. The overall effect is somewhat different from that of the previous example. Since the pulsation totals of the local streams are larger, their pulsations do not converge significantly in mm. 41-54. Rather, the approximately equidistant attacks of the local polyrhythm suggest a regular pulse played with a slight rubato. The passage also is timed to begin just before a region of maximum divergence in

Example 3.3 - Analytical arrangement of *Night Fantasies*, mm. 41-54.

Musical score for measures 41-44. The score is written for piano and includes a treble clef staff, a bass clef staff, and a grand staff. Measure 41 is marked with a circled '41'. Measure 42 contains a circled '(61)'. Measure 43 contains a circled '(62)'. Measure 44 contains a circled '(62)' and a circled '5' above a slur. The grand staff includes a circled 'O₂₄' in the bass clef staff and a circled 'X₂₀' in the treble clef staff.

Musical score for measures 45-48. The score is written for piano and includes a treble clef staff, a bass clef staff, and a grand staff. Measure 45 is marked with a circled '45'. Measure 46 contains a circled '(63)'. Measure 47 contains a circled '(64)'. Measure 48 contains a circled '(64)'. The grand staff includes a circled 'O₂₅' in the bass clef staff and a circled 'X₂₁' in the treble clef staff.

Musical score for measures 49-66. The score is written for a grand piano with two staves (treble and bass clef). Measure 49 is marked with a circled '49'. Measures 65 and 66 are marked with circled numbers. A fermata is placed over measure 65. A circled '5' is written above the staff in measure 65. A circled '26' is written above the bass staff in measure 65. A circled '66' is written above the bass staff in measure 66.

Musical score for measures 52-67. The score is written for a grand piano with two staves (treble and bass clef). Measure 52 is marked with a circled '52'. Measures 66 and 67 are marked with circled numbers. A circled '5' is written above the staff in measure 67. A circled '27' is written above the bass staff in measure 67. A circled '22' is written below the bass staff in measure 66.

the long-range polyrhythm. (It begins on pulsation O_{24} .) At first the long-range pulsations disturb the quasi-regularity of the local polyrhythm only slightly. Then they begin to converge, and after the span of maximum convergence in m. 53 the music accelerates and the previous texture is spun into a disjunct flurry of single notes.

Another example in which local and long-range polyrhythms are combined is the well-known passage from *Night Fantasies* reproduced as example 3.4. Thomas Warburton has written about this passage that "... the left hand semiquavers [are] oriented to the faster pulse, the right hand semiquaver quintuplets to the slower,"⁵⁵ but in fact the surface rhythms reflect the underlying pulsations only obliquely. The local polyrhythm is 16:15 with pulsations of the fast stream occurring every four sixteenths to the slow stream's four quintuplet sixteenths. There are two coincidence points articulated in the passage, the first on beat 3 of m. 313, before the fast stream has settled into its regular speed, and the second on the third beat of m. 316. The speeds generated are $MM\ 118\frac{1}{8}$ and $MM\ 126$, neither of which is a whole-number multiple of the speed of its underlying stream. The local and long-range polyrhythms are coordinated only in mm. 314-315 when the eighth pulsation of the local fast stream occurs on pulsation 128 of the long-range fast stream, and the ninth pulsation of the local slow stream occurs on pulsation 104 of the long-range slow stream. The irony and the humor in this passage come from the fact that the surface pulsations are doubly out of sync — not only with each other, but with the pulsations of the underlying polyrhythm as well.

⁵⁵Warburton, "A Literary Approach to Carter's *Night Fantasies*," *The Music Review* 51, no. 3 (August 1990): 211.

Example 3.4 - *Night Fantasies*, mm. 312-318.

The image displays three systems of musical notation for piano, numbered 312, 314, and 317. Each system consists of a grand staff with a treble and bass clef. The first system (mm. 312-313) includes performance markings: *mf cresc.*, *legato*, *f*, and *p legato*. A bracket labeled *ped* spans the first two measures. The instruction *evenly balanced* is written at the end of the system. The second system (mm. 314-315) continues the melodic and harmonic development. The third system (mm. 317-318) features markings for *mf* and *p scorrevole*. The score includes various musical notations such as slurs, ties, and dynamic markings.

SUBDIVISIONS OF PULSATIONS

Carter also uses the pulsations of his long-range polyrhythms as the basis for a variety of faster periodic patterns, as in example 3.5.

Example 3.5 - *Night Fantasies*, mm. 96-98.

Beginning in m. 96 each hand plays three attacks. The first and third are pulsations, and the second occurs halfway between the pulsations. Here, the sense of pulsations moving at different speeds is enhanced by the perfect fifths (plus octaves) which connect the two streams harmonically. With each occurrence, the upper note of a fifth comes a bit sooner after the lower one.

The equal subdivision of the time between pulsations is used in a more elaborate way in example 3.6. This excerpt comes from Carter's 1988 duet for flute and cello, *Enchanted Preludes*, which makes use of a polyrhythm of 56:45. The fast stream is played by the cello, with beat divisions mainly of 4 and 7, which are factors of its pulsation total 56. The slow stream is played by the flute, using beat divisions of 3, 5, and 9, which are factors of its pulsation total, 45. In example 3.6, pulsations of the cello's stream (marked with 'O's) recur every 36 sixteenths. Pulsations in the flute's stream (marked with 'X's) recur every 56 quintuplet sixteenths. In the cello part, the surface rhythm strongly suggests an arrangement of the sixteenths of the cello's pulse grid into twelve groups of three sixteenths each. This gives a distinctly waltz-like feel to cello's music. At the same time the 56 quintuplet sixteenths between flute pulsations are divided into eight groups of seven. In order to clarify these groupings, I have renotated the attacks of each instrument on single lines added above and below the score. In my annotations a quarter note equals one group, and the beat divisions represent the pulses of the pulse grid. Note that the quarter note value was chosen arbitrarily, and the two added lines move at different tempi.

There are some problems with my annotations: it is not hard to hear the D6 on the first flute pulsation as lasting through two groups, but more disruptive is the accented Eb6 two measures later which comes a quintuplet sixteenth "early." Nevertheless, it is possible to project onto each instrument's stream a kind of metric layering, as in figure 3.1.

Figure 3.1 - Metric layering the cello part in the excerpt from Enchanted Preludes (Example 3.6).



The top line of figure 3.1 represents the time between two pulsations of the cello's stream. The bottom line represents the pulses of the cello's pulse grid, here determined by a notated beat division of sixteenths. The middle line indicates that the pulses of the pulse grid are articulated in this particular musical context in groups of three. Interestingly, this number turns out to be a factor of the flute's pulsation total, 45 ($= 3^2 \times 5$). Likewise, the flute plays surface groupings of seven which is a factor of the cello's pulsation total 56 ($= 2^3 \times 7$). This creates a kind of mutual influence between the two streams of the polyrhythm: a stream's beat division and pulse grid are determined by its own pulsation total, but its surface groupings reflect the pulsation total of the other stream.

The division of the duration between pulsations into equal lengths is also a prominent feature of Carter's Oboe Concerto. A particularly interesting passage begins with the sudden cessation of the orchestra's agitated music in mm. 90-91, and the resumption in m. 92 of the oboe's tranquillo melodic line from the opening of the piece. Recall that the polyrhythm of the Oboe Concerto consists of two streams, one for the oboe and its concertino of four violas and percussion, and one for the orchestra. At the notated tempo, $\text{♩} = 70$, the numbers of beats between pulsations for each stream are as in figure 3.2.

Figure 3.2 - Beat division formulas for the Oboe Concerto polyrhythm at a tempo of $\text{♩} = 70$.

$$\text{Oboe and concertino: } B = \frac{T \times C}{P} = \frac{70 \times 18}{63} = 20$$

$$\text{Orchestra: } B = \frac{T \times C}{P} = \frac{70 \times 18}{80} = \frac{63}{4}$$

In the passage after m. 92, Carter follows his usual practice and writes the oboe's music using a beat division of three, which is a factor of the oboe's pulsation total, 63 (= $3^2 \times 7$). Similarly, the orchestra plays beat divisions that are multiples of two, a factor of its pulsation total 80 (= $2^4 \times 5$). These beat divisions establish pulse grids of triplet eighths for the oboe and concertino and sixteenths for the orchestra. As in the example from *Enchanted Preludes*, Carter arranges the pulses of each stream's pulse grid into larger groups that form an intermediate layer between the grids and the pulsations of the

underlying polyrhythm. The triplet eighths of the oboe and concertino's pulse grid are grouped in multiples of five (and occasionally subdivided, as during the viola trills in mm. 93-94 and 107, and the oboe's figuration in m. 111). The sixteenths of the orchestra's pulse grid are arranged in groups of 21 (and also occasionally subdivided). The pulse grid, groups, and pulsations together give each layer a three-tiered metric plan, as I have indicated in my renotation of the passage in example 3.7.

The top half of each system in example 3.7 is a reduction of the full score of the Oboe Concerto. The bottom half is my renotation. Both halves show the division of the texture into two instrumental layers (oboe plus concertino, and orchestra), each with its associated stream of the underlying polyrhythm. In my renotation, the pulses of the oboe and concertino's pulse grid are written as quintuplet sixteenths in order to show the groups at the level of the notated quarter-note beat. The pulses of the orchestra's pulse grid are written as septuplet sixteenths, so that each orchestral group lasts for one dotted half. As in the renotation of the *Enchanted Preludes* example, these note values were chosen arbitrarily, and each stream of the renotation is written at a different tempo. In both streams, a dashed bar line precedes each pulsation of the long-range polyrhythm.

The renotation in example 3.7 reveals that the rhythmic organization of each layer is much simpler than the notation in the score might suggest. The rhythm of the oboe line between pulsations fourteen and fifteen, for example, articulates the pattern  and the equidistant attacks in the orchestra articulate an even simpler pattern. The rhythmic complexity of the passage comes from the constantly changing resultant rhythm produced by the simultaneous presentation of the

Example 3.7 - Reduction and renotation of the Oboe Concerto, mm. 92-113.

The image displays a musical score for Example 3.7, which is a reduction and renotation of the Oboe Concerto, measures 92-113. The score is presented in two systems. The first system covers measures 92-110, and the second system covers measures 111-113. The score includes parts for Oboe, 4 Violins, Orchestra, and Cello. The Oboe part is marked with dynamics such as *p*, *pp*, and *ppp*, and includes a trill in measure 110. The Violin parts are marked with dynamics *p* and *pp*. The Cello part is marked with dynamics *p* and *ppp*. The score includes various musical notations such as slurs, ties, and dynamic markings.

This musical score page contains three systems of music for Oboe (Ob.), Violins (Vlas.), and Orchestra (Orch.).

- System 1 (Measures 98-110):** The Oboe part (Ob.) features a melodic line with triplets and dynamics ranging from *ppp* to *mp*. The Violins (Vlas.) play a rhythmic accompaniment with dynamics from *ppp* to *p*. The Orchestra (Orch.) part includes a section marked *ff* and *ppp*, with a dynamic change to *p* and *pp* indicated by a double-headed arrow.
- System 2 (Measures 111-115):** The Oboe part continues with a melodic line, marked *O15*. The Violins (Vlas.) play a rhythmic accompaniment, marked *ff* and *ppp*. The Orchestra (Orch.) part includes a section marked *ff* and *ppp*, with a dynamic change to *p* and *pp* indicated by a double-headed arrow.
- System 3 (Measures 116-118):** The Oboe part continues with a melodic line, marked *O15*. The Violins (Vlas.) play a rhythmic accompaniment, marked *ppp* and *p*. The Orchestra (Orch.) part includes a section marked *ppp* and *p*.

Additional markings include *X14* and *ff* above the Violins and Orchestra parts, and *ff* and *ppp* above the Oboe part. The score is written in a standard musical notation with stems and beams.

This musical score page contains two systems of music. The first system, measures 103-110, features three staves: Oboe (Ob.), Violas (Vlas.), and Orchestra (Orch.). The Oboe part begins at measure 103 with a dynamic of *pp* and includes a trill. The Violas part starts at measure 104 with a dynamic of *pp*. The Orchestra part includes strings and woodwinds, with dynamics ranging from *pp* to *p*. The second system, measures 111-118, continues the Oboe and Violas parts, with the Oboe part starting at measure 111 and the Violas part at measure 112. The Orchestra part continues with dynamics of *p* and *pp*. The score includes various musical notations such as trills, slurs, and dynamic markings.

This musical score page contains measures 108 through 117. The instruments and parts are as follows:

- Ob. (Oboe):** Measures 108-117, marked *pp*. Includes a trill in measure 108 and a triplet in measure 117.
- Vlas (Violins):** Measures 108-117, marked *p*. Includes a vibrato marking in measure 117.
- Orch. (Orchestra):** Measures 108-117, marked *pp*. Includes a section for *X₂₁ fl./m./bhn* in measures 108-110 and *vc./cb.* in measures 111-117.
- O₁₇ (Oboe 17):** Measures 108-117, marked *p*. Includes a triplet in measure 117.
- O₁₁ (Oboe 11):** Measures 108-117, marked *p*. Includes a triplet in measure 117.
- X₂₁ (Xylophone):** Measures 108-117, marked *pp*. Includes a triplet in measure 117.

The score features complex rhythmic patterns, including triplets and trills, and dynamic markings such as *pp* and *p*. A large bracket groups the Oboe parts across the measures.

simplified patterns, each at a different speed. The quarter notes in my notation of the oboe and concertino parts last five triplet eighths at the notated tempo $\text{♩} = 70$, which means their speed is $\frac{70 \times 3}{5}$ or MM 42. Similarly, the periodic attacks in the orchestra take place every 21 sixteenths at $\text{♩} = 70$, meaning their speed is $\frac{70 \times 4}{21}$ or MM $13\frac{1}{3}$. Of particular interest is the fact that the quasi-metric patterns formed by the pulsations, groups, and pulse grids, guide the rhythmic organization of their respective instrumental layers independent of the notated meter, and that the contrasting speeds of the two rhythmic patterns are both whole-number multiples of their respective polyrhythmic streams (see figure 3.3).

Figure 3.3 - Speeds in the Oboe Concerto.

$$\text{Oboe and concertino: } S = \frac{P}{C} = \frac{63}{18} = 3\frac{1}{2} \quad 42 = 3\frac{1}{2} \times 12$$

$$\text{Orchestra: } S = \frac{P}{C} = \frac{80}{18} = 4\frac{4}{9} \quad 13\frac{1}{3} = 4\frac{4}{9} \times 3$$

Beginning in m. 116 the oboe and its accompanying percussion veer away from the rhythmic plan established in the previous measures, leaving even the articulation of its pulsations to the violas alone. They take up a regular pattern of attacks every two groups until m. 123, then change to attacks every three groups beginning in m. 124. At the same time, the orchestra's music continues to divide the time between pulsations into three equal parts. (See example 3.8.)

Example 3.8 - Reduction and renotation of the Oboe Concerto, mm. 125 -142.

The musical score is presented in two systems. The first system covers measures 125 to 142, and the second system continues the music. The instruments and their parts are as follows:

- Oboe:** Measures 125-142. Includes dynamic markings *mf*, *p*, and *mf-p*. Performance instructions include *p secco* and *X24*. Fingerings and breath marks are indicated.
- Percussion:** Measures 125-142. Includes dynamic markings *mf*, *p*, and *mf-p*. Performance instructions include *p secco* and *X24*.
- 4 Violas:** Measures 125-142. Includes dynamic markings *mf-p*, *p*, and *mf-p*. Performance instructions include *X24*.
- Orchestra:** Measures 125-142. Includes dynamic markings *p* and *pp*. Performance instructions include *X24*.

The second system continues the music for the Oboe, Percussion, and 4 Violas. It includes dynamic markings *mf*, *p*, and *mf-p*. Performance instructions include *X24* and *5*. The score concludes with a final measure marked *p*.

This musical score page contains four staves. The top staff is for Oboe (Ob.), starting at measure 132, with dynamics *mf* and *f*. The second staff is for Percussion (Perc.), with dynamics *mf* and *f*. The third staff is for Violas (Vlas.), with dynamics *mf* and *f*, and includes markings for *O₂₀* and *X₂₅*. The bottom staff is for the Orchestra (Orch.), with dynamics *mf* and *sp*. The score continues with an Oboe part on the right side, including markings for *O₂₀* and *X₃₅*, and a string part with dynamics *p*.

In this passage the texture splits into three layers: the free rhythm of the oboe and its percussion is juxtaposed against the two, more regular metric designs played by the violas and the orchestra.

At m. 142, the tempo changes to $\text{♩} = 46 \frac{2}{3}$ and the orchestra begins an accelerando which leads to the return of its agitated music. The change of tempo brings new pulse grids to both streams of the polyrhythm. The pulse grid of the oboe and concertino's stream consists of 40 triplet eighths, which are arranged into eight groups of five by the attacks of the violas, rejoined by the oboe in m. 147. The equidistant attacks continue until just prior to the orchestral climax in mm. 156-157.

The entire passage from mm. 92-157 lasts more than two and one-half minutes, during which the contrast between rhythmic regularity and irregularity takes on the character of a dramatic confrontation. The oboe's irreverent departure after m. 110 from the regular patterns discussed above, and even from its own pulsations, is answered by the growing restlessness of the orchestra, heard in the string crescendi after m. 128 and the short horn and trombone solos in mm. 129-32. When the oboe begins its return to rhythmic regularity after m. 140, the orchestra accelerates into agitated irregularity. As in Carter's Brass Quintet, the instruments' attempts to play quiet music together are continually frustrated, here by the oboe's playfulness and the orchestra's impatience.

PULSATIONS AS FORMAL LANDMARKS

Even when the pulsations of a long-range polyrhythm seem far removed from the rhythmic surface of a composition, they can still mark important moments of transition or arrival. One of the most dramatic episodes in *Night Fantasies* involves the cross-cutting of a single line of rapid notes marked *scorrevole* with much slower, mainly chordal music. The *scorrevole* begins in m. 320, but is quickly interrupted by a loud chord on pulsation O_{131} , which initiates the first passage of slow chords (see example 3.9).

Example 3.9 - Night Fantasies, mm. 319-326.

The image displays a musical score for three systems of music, numbered 319, 321, and 323. The notation is written on grand staves (treble and bass clefs). The first system (319) begins with a tempo marking of *♩ = 90* and a dynamic of *mf*. It includes the instruction *legato leggero* and a *mp scordate* marking. The second system (321) starts with a tempo of *♩ = 90* and a dynamic of *mp*, featuring a *pp* dynamic marking. The third system (323) includes a *più f. espr.* marking. The score contains various musical notations such as slurs, ties, and dynamic hairpins. There are also some handwritten annotations and markings like *X₁₀₀*, *O₁₃₀*, and *X₁₀₀* scattered throughout the score.

The *scorrevole* music interrupts twice more in the following twenty-five measures. In m. 328 the interruption emphasizes pulsation X_{109} from the slow stream (see example 3.10).

Example 3.10 - *Night Fantasies*, mm. 327-328.

The image shows a musical score for two staves, likely piano and bass. The tempo is marked as $\text{♩} = 90$. The score begins at measure 327, marked with a piano (*p*) dynamic. The music features complex rhythmic patterns, including triplets and sixteenth notes. A dynamic change to mezzo-forte (*mf*) occurs in measure 328. The score includes various performance markings such as *pp*, *mf*, and *EP*. There are also annotations like O_{134} and X_{109} with arrows pointing to specific notes. The notation includes slurs, ties, and fingering numbers (e.g., 3, 7, 1).

In m. 336 the interruption emphasizes the near coincidence of pulsations O_{138} and X_{112} (see example 3.11).

Example 3.11 - *Night Fantasies*, mm. 333-338.

The image shows two systems of handwritten musical notation for piano, measures 333 through 338. The notation is in G major and 4/4 time. The first system (measures 333-335) features a treble clef with a melodic line and a bass clef with a supporting line. Annotations include X_{111} above measure 334, O_{37} above measure 335, and O_{138} below measure 335. Dynamics include *mp*, *p*, and *marc.*. The second system (measures 336-338) continues the piece. Annotations include X_{112} above measure 336, O_{139} above measure 338, and O_{138} below measure 338. Dynamics include *marc.*, *f*, *espr.*, and *p*. The notation includes various rhythmic values, accidentals, and articulation marks.

The most extended appearance of the *scorrevole* music comes in mm. 347-354, but this passage also proves to be a temporary interruption: in m. 352 the fast line swoops down into the bass clef then quickly scampers back up to the piano's highest register, leaving behind a wash of low notes (caught by the pedal) from which the slow chords once again emerge (see example 3.12).

This remarkable textural effect begins with the B2 in the left hand in m. 352, and continues as the slow chords are taken up again on the last attack of m. 354. These two events occur on pulsations O_{146} and O_{147} respectively. In the meantime the *scorrevole* has come to an end in m. 354 on a pianississimo C6 which occurs on pulsation X_{119} .

Throughout this extended passage significant turning points are marked by pulsations of the underlying polyrhythm. Further, there is a consistent connection between the *scorrevole* music and the pulsations of the slow stream on the one hand, and the slow chords and the pulsations of the fast stream on the other.

Example 3.12 - Night Fantasies, mm. 352-357.

The image displays three systems of musical notation for the piece 'Night Fantasies', measures 352 through 357. The first system, starting at measure 352, is marked with a tempo of $\text{♩} = 126$ and a key signature of one sharp (F#). It features a piano (*P*) dynamic with a crescendo (*cresc.*) and concludes with a *dim. molto* instruction. The second system, beginning at measure 353, includes dynamic markings of *P*, *[silenc]*, *dim.*, *ppp*, *mf*, and *estd.*. The third system, starting at measure 355, is marked with a tempo of $\text{♩} = 94.5$ and includes dynamic markings of *ppp*, *mf*, and *estd.*. The notation includes treble and bass clefs, various note values, rests, and performance markings such as *mf*, *ppp*, and *estd.*.

Carter also uses the pulsations of his long-range polyrhythms to delineate large-scale formal sections. Recall that the polyrhythm of String Quartet No. 4 has four streams, one for each of the four instruments, and that numerous partial coincidence points occur due to common factors among some, but not all of the pulsation totals. The pulsation totals of the polyrhythm, and their prime factorizations, are recalled in figure 3.4.

Figure 3.4 - Prime factorizations of the pulsation totals in String Quartet No. 4.

$$\begin{array}{ll} \text{Violin I: } P = 120 = 2^3 \times 3 \times 5 & \text{Violin II: } P = 126 = 2 \times 3^2 \times 7 \\ \text{Viola: } P = 175 = 5^2 \times 7 & \text{Cello: } P = 98 = 2 \times 7^2 \end{array}$$

In chapter 1 we found that if the pulsation totals of two or more streams share a greatest common factor of 'n', the streams will coincide 'n' times per cycle. A list of the greatest common factors among the pulsation totals of String Quartet No. 4 is given in figure 3.5, together with a diagram of the partial coincidence points that arise from the common factors.

Figure 3.5 - Greatest common factors among pulsation totals in String Quartet No. 4, and a diagram of partial coincidence points.

Vn I/VnII: GCF = 6 Vn I/Vla: GCF = 5
 Vn I/Vc: GCF = 2 Vn I/Vn II/Vc: GCF = 7
 Vn II/Vc: GCF = 14

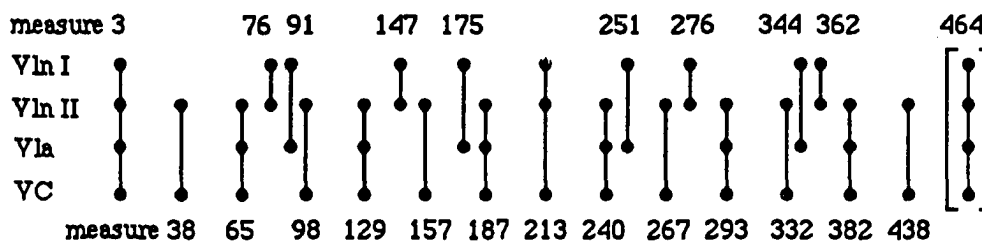

In his program note for the String Quartet No. 4, Carter remarks that "...the work is in one long, constantly changing movement. In the background, however, there is a suggestion of the traditional four-movement plan of the classical string quartet..."⁵⁶ The first of these "meta-movements," *Appassionato*, begins with the initial coincidence point of the polyrhythm, on the downbeat of m. 3. The second, *Scherzando*, is marked at m. 118, but actually begins a sixteenth earlier, on pulsation number 32 of the first violin, which, having dominated the first section of the piece, opens the second by insistently repeating the dyad B3-C#5 (see example 3.13).

⁵⁶Carter's program note to the score of String Quartet No. 4 (Boosey & Hawkes, HPS 1130).

The transition to the *Scherzando* is announced by the dramatic descent of the first violin in mm. 113-114. The low point of the descent — the dyad G3-A4 at the end of m. 114 — is the first violin's thirty-first pulsation, which occurs exactly one-fourth of the way through the polyrhythm.

As mentioned earlier, the third section of the piece, *Lento*, begins on the fourth beat of m. 213 with the partial coincidence point shared by the violins and cello. This attack marks the halfway point of the polyrhythm. The final section, *Presto*, is marked at m. 312, but the faster tempo is disguised by the long note values until the tumultuous outburst in mm. 316-19 (not shown).

The transition to the *Presto* is initiated by the second violin, which interrupts the *Lento* first at m. 272 with a series of tenuto notes followed by an emphatic gesture of three attacks at the beginning of m. 273 (not shown). Tenuto becomes staccato in m. 296, and the emphatic cadential gesture returns in m. 299, and again in mm. 304-305 to close the second violin's solo with two loud chords. (See example 3.14.)

Example 3.14 - String Quartet No. 4, mm. 303-315.

$\text{♩} = 63$

303 X_{90}

306 X_{11} X_{12} X_{13} X_{14} X_{15} X_{16} X_{17} X_{18} X_{19} X_{20}

311 $\text{♩} = 63$ *Presto* $\text{♩} = 94.5$ X_{21} X_{22}

The motive of staccato notes followed by a loud chord is taken up in mm. 305-306 by the violins and cello, led by the first violin which plays the accented Eb4-F4 dyad on its 91st pulsation — exactly three-fourths of the way through the polyrhythm. Thus, the four sections of the piece are of almost exactly equal length, with important transitional moments marked by symmetrically-located pulsations.

POLYRHYTHMS AND HARMONY

One of the most interesting aspects of Carter's recent music is the way the polyrhythmic designs of his pieces are coordinated with certain features of their harmony. Often such coordination gives a degree of harmonic and rhythmic continuity to fairly extended passages which exhibit a great deal of surface variety. One technique Carter uses is to repeat a particular pitch collection on successive pulsations. A familiar example is the repeated four-note chord (G1-Ab2-D5-C#6) near the end of *Night Fantasies* which tolls on every one of the last sixteen pulsations of the slow stream preceding the final coincidence point.¹ Another example, this one involving both streams of the polyrhythm, occurs in mm. 126-134, given as the last part of example 3.16.

⁵⁷This chord, along with the all-interval chords which include it, is a prominent feature of the analyses of Schiff, *The Music of Elliott Carter*, 316-318; Ciro Scotto, "Elliott Carter's *Night Fantasies*: The All-Interval Series as Registral Phenomenon," unpublished paper presented at the Society for Music Theory conference, Oakland, CA, November 1990; Warburton, "A Literary Approach;" and Andrew Mead, "Twelve-Tone Composition and the Music of Elliott Carter," in *Musical Pluralism: Aspects of Structure and Aesthetics in Music Since 1945*, ed. Elizabeth West Marvin and Richard Hermann, forthcoming.

Example 3.16 - *Night Fantasies*, mm. 105 -134.

105 *f* *mf* *X₄₁* *X₄₂*

109 *f* *mf* *one phrase to [123]* (*—*) *oss*

112 *oss*

115 *piú f* *oss* *X₄₄*

119 *X₄₅* *oss*

123 (♩ = 43)

p

126

p

mf leggero

129

p

♩ = 67.5

131

mf

p

mf

133

mf

p

mf

Example 3.17 is an analytical arrangement of some of the music in example 3.16. In the arrangement I have divided the texture into two layers and notated each on a separate grand staff. The arrangement begins with pulsation χ_{41} , on the downbeat of m. 105. The top staff of my arrangement corresponds to the fast stream, and the bottom grand staff corresponds to the slow stream. The assignment of musical events to streams was initially made on the basis of beat division: I have assumed that every event that occurs on a quintuplet beat division "belongs" to the slow stream, and every event that occurs on a sixteenth- or eighth-note beat division "belongs" to the fast stream. Events that occur on a beat of the notated meter are ambiguous, but, as we will see, the stream to which they "belong" can be determined by other means.

Once the texture has been partitioned in this way, one can observe that the pitch events associated with the slow stream are always either members of interval-class 4, or of three- or four-note set classes with a predominance of that interval class. Similarly, pitch events associated with the fast stream are always either members of interval-class 5, or of three- or four-note set classes featuring that interval class. For example, the chord on beat two of m. 108, F#3-C#7, is a member of interval-class 5, and thus belongs to the fast stream. Similarly, the chord on the downbeat of m. 113, Gb1-Bb1-D3, is a member of set class (048), arranged as a major third plus a major 10th. This chord clearly belongs to the interval-class 4 stream. Thus each polyrhythmic layer has its own distinct rhythmic groupings, and its own distinct harmonic content as well.

The harmonic connection between the two layers in this passage is made primarily through the use of set-class (0146), one of the two all-interval tetrachords and an old Carter favorite. This set class is consistently articulated

Example 3.17 - Analytical arrangement of *Night Fantasies*, mm. 105-124.

105 $\text{♩} = 94.5$

105

105

109

109

Annotations: $\text{♩} = 94.5$, O_{51} , X_{41} , X_{42} , 8^{va} , O_{52} , (0167) , (0146) , (0146) , (0268) , (0268) , (0257) , (0146) , (027) , (0146) , (0146) .

112 $(0158) = ic5 + ic5$

O_{53}

(0146) (0146)

112

X_{43}

(048) $(0158) = ic4 + ic4$ (048) (048)

(048)

115 O_{54}

(0146)

115 X_{44}

Musical score for measures 118-120. The score is written for piano in two systems. The first system (measures 118-120) features a treble clef staff with notes marked with fingering '5' and an ornament 'O₅₅'. The bass clef staff has notes with fingering '5' and a bracketed measure labeled '(0146)'. The second system (measures 118-120) features a treble clef staff with notes marked with fingering '5' and an ornament 'X₄₅'. The bass clef staff has notes with fingering '5'.

Musical score for measures 121-123. The score is written for piano in two systems. The first system (measures 121-123) features a treble clef staff with notes marked with fingering '5' and ornaments 'O₅₆' and 'O₅₇'. A bracketed measure is labeled '(0146)'. The bass clef staff has notes with fingering '5' and a bracketed measure labeled '(0146)'. The second system (measures 121-123) features a treble clef staff with notes marked with fingering '5' and an ornament 'X₄₆'. The bass clef staff has notes with fingering '5' and a bracketed measure labeled '(0146)'. A measure at the bottom left of the second system is marked with a '5'.

in the passage as a pair of dyads, one each from interval-class 4 and interval-class 5. Further connection is made by means of set-class (0158), the only tetrachord divisible into either a pair of interval class 4s or a pair of interval class 5s. The two instances of set class (0158) in m. 112 illustrate this point. The first occurs within the top stream, articulated as a pair of interval class 5s: Bb-F, and F#-C#. Then, immediately afterwards, set-class (0158) is reinterpreted by the lower stream as a pair of interval class 4s: E-C and B-G. This kind of reinterpretation of the interval content of a harmony is typical of Carter's harmonic practice.⁵⁸

The close coordination of harmony and polyrhythmic stream in this passage also provides a means of associating non-contiguous pitch events. Pulsation X_{46} , sounding the dyad Eb4-G4 on the downbeat of m. 123, is a clear moment of arrival in the music. The pulsation that immediately precedes it is O_{56} , two measures earlier in the other stream. Note that the harmony that occurs on this pulsation is the dyad F#1-C#2, and that together the two dyads form an instance of set-class (0146). Similarly, the pulsation that immediately follows the Eb-G dyad is O_{57} , which articulates the dyad A3-E4, again forming set-class (0146) with the Eb-G dyad.

Finally, note that pulsations X_{47} , X_{48} , and X_{49} all articulate the same dyad D4-Bb4, while pulsations O_{58} , O_{59} , and O_{60} all articulate the dyad Ab4-Db5. Since the pulsations of the two streams occur in fairly close proximity in these measures, the two repeated dyads are easily heard as members of a four-note chord (again a member of set class (0146)), the articulation of which changes as the D-Bb dyad first precedes then falls behind the Ab-Db dyad.

⁵⁸See for example Andrew Mead's discussion of the use of trichords in the *Piano Concerto* in "Twelve-Tone Composition."

These measures illustrate the continuing role of set class (0146) as a link between the two layers of the texture. First the set class is presented contiguously, as dyads from each layer alternate. Then the constituent dyads begin to move apart, slowing down eventually to the rate of the underlying pulsations as other events move in to occupy the faster rhythmic surface. This is also a clear example of how an understanding of long-range polyrhythms can be extremely helpful from a performance-practice standpoint. Carter has said about this passage "...it's very hard to get pianists to play that correctly. That whole passage is built on those two chords, with ornaments around them as I remember."⁵⁹

The harmonic stratifications in the preceding examples suggest ways of resolving the complex textures of Carter's recent music into distinct voices. As with most polyphonic music, an understanding of how these voices are constituted and combined can help to make the music more compelling for the listener.

ANOMALIES IN CARTER'S POLYRHYTHMIC PRACTICE

Although the pulsations of Carter's long-range polyrhythms usually make a vivid contribution to the aural experience of his compositions, there are also passages in which they are far removed from the musical surface. There are many cases in which striking moments of arrival occur without reference to the underlying polyrhythm, or in which the pulsations are subsumed by a flurry of surface activity (see example 3.15).

⁵⁹Interview with the author, 5/14/92.

Example 3.15 - *Night Fantasies*, mm. 413-415.

Musical score for Example 3.15, *Night Fantasies*, mm. 413-415. The score is written for piano and consists of two staves. It features a complex rhythmic pattern with many beamed notes and rests. The key signature has one flat (B-flat). The tempo is marked $\text{♩} = 94.5$. Dynamics include *f* (forte) and *ff* (fortissimo). There are also markings for *XIII* and *124*.

Similarly, the regularity of a stream's pulsations is sometimes concealed by long lines that accelerate or ritard very freely.⁶⁰ Ursula Oppens reports that when she asked Carter about the lack of rhythmic regularity in the slow chords after m. 355 in *Night Fantasies*, "he said he wanted it to sound rubato."⁶¹ As the composer puts it: "There are places where I've sort of obliterated, or covered [the polyrhythm] up. I remember that because I began to wonder whether this was a little bit too mechanical."⁶²

Carter has expressed little interest in being systematic for its own sake, and he has no qualms about departing from a rigorous adherence to any compositional plan if it does not produce the musical result he is after:

Now it's true that in writing my own works I sometimes try quasi-geometric things in order to cut myself off from habitual ways of thinking about particular technical problems.... Nonetheless, if what I come up with by these methods is unsatisfactory from the point of view of what I think is interesting to hear, I throw it out without a second thought.⁶³

Carter's concern with music before method occasionally results in anomalous situations in which individual pulsations of his polyrhythms are slightly displaced or omitted altogether, and in the case of at least two works — *Triple Duo*, and *Changes* — there are significant alterations to the fabric of the polyrhythm as a whole. As he worked out the final sections of *Triple Duo* Carter began to feel that the polyrhythm was too long for the music, and he

⁶⁰See, for example, the sweeping accelerando of the first violin in mm. 18-31 of String Quartet No. 4.

⁶¹Interview with the author, 6/5/92.

⁶²Interview with the author, 5/14/92.

⁶³Edwards, *Flawed Words and Stubborn Sounds*, 81.

made a cut.⁶⁴ Pulsations in the woodwind stream leave off after number 58 in m. 510, and the last pulsation in the strings is their number 50 in m. 515. The piano's stream continues nearly to the end, stopping at pulsation number 60 in m. 532, on the last attack before the enormous collision four measures from the end which marks the polyrhythm's final coincidence point.⁶⁵

In *Changes*, as in *Night Fantasies*, a polyrhythm of two streams is articulated by a single instrument. A brief cut in the polyrhythm probably came about because of revisions Carter made as he worked on the piece. He had originally sketched a much shorter work, but considerably expanded the final version at the request of guitarist David Starobin, who had commissioned it.⁶⁶ In the earlier version the dramatic chords beginning in m. 110 were much faster, but Carter rewrote the passage because Starobin felt the chords could not be negotiated effectively at the original tempo.⁶⁷ In the finished score, pulsations in both streams disappear after m. 102, and are taken up again in m. 115, about five beats behind schedule. A second anomaly is the absence of an initial coincidence point, which should occur on the second beat of the first measure. The initial 5/4 meter signature — which affects only the first bar — hints at the reason. Had the first measure been 4/4, like most of the rest of the piece, the coincidence point would have been on the downbeat.

⁶⁴Remarks made by Carter at the Centre Acanthes festival in Avignon, July, 1991. Also see Schiff, "Elliott Carter's Harvest Home," 2.

⁶⁵Cf. Schiff's remark that the cut in the polyrhythm occurs "at bar 442" ("Elliott Carter's Harvest Home," 2).

⁶⁶See Schiff, "Elliott Carter's Harvest Home," 4. Also see letters grouped with the sketches for *Changes* in the Elliott Carter Collection of the Paul Sacher Foundation.

⁶⁷Letters grouped with the sketches for *Changes* in the Elliott Carter Collection of the Paul Sacher Foundation.

It is as though the piece has burst its seams, perhaps another allusion to its formative growth.

Conclusions

The explanation of long-range polyrhythms that I have presented here has important ramifications, both for Carter scholarship and for broader issues in post-tonal theory. The polyrhythmic compositions I have described span a ten-year period of the composer's career and include most the major works of the 1980s. In the past three years he has completed at least two new polyrhythmic works — *Quintet for Piano and Wind Instruments* (1991) and *Partita* (1993) — and in interviews and private communications Carter has given every indication that long-range polyrhythms continue to play an important role in his rhythmic thinking.

In light of Carter's extraordinary productivity over the past thirteen years, the scholarly literature about his music is somewhat out of date. Carter's rhythmic practice evolves only to 1961 in Jonathan Bernard's 1988 analysis, at which time it reaches "a kind of culmination."⁶⁸ Similarly, for David Harvey (writing in 1986) Carter's "later music" extends no further than the *Concerto for Orchestra*.⁶⁹ While these authors can hardly be faulted for not predicting the future, some of their conclusions are in need of revision. Bernard, for example, charts Carter's career as a series of progressively better technical solutions to the problems posed by each new work. The consistency of method in Carter's recent works suggests a very different view for the period after 1980.

⁶⁸Bernard, "Elliott Carter's Rhythmic Practice," 197.

⁶⁹Harvey, *The Later Music of Elliott Carter*.

Carter's recent practice also raises questions about the connection between compositional method and expressive intent in his music. Carter has always maintained that his techniques and methods arise directly from the circumstances of a particular composition. He writes that he "has always prized a continuous exploration of musical means largely invented as various imaginative needs were felt."⁷⁰ The implication is that novel methods are required in order to realize the unique expressive world of a particular piece. As Schiff puts it, "...each new work would be a fresh start, a new crisis."⁷¹ But in the 1980s Carter wrote an astonishingly diverse assortment of pieces using materials that are quite similar. *A Celebration of Some 100 X 150 Notes* (1986), *Enchanted Preludes* (1988) and *Anniversary* (1989), for example, all use a 56:45 polyrhythm, but the three pieces are entirely different in character and mood. The underlying similarity of Carter's recent procedures is not a sign that his compositions have become stylistically uniform. Rather, his new approach facilitates the expression of a wide variety of musical conceptions in a language that no longer must be re-invented for every piece.

Finally, Carter's recent compositions have significant implications for more general issues in post-tonal music. The close relationship Carter has developed between the pulsations of a long-range polyrhythm and the pulse grids that guide a composition's faster rhythmic surface demonstrates how considerations of large-scale form can be systematically integrated with rhythmic patterning at the beat level. In the area of harmony, the periodic recurrence of particular pitch collections on successive pulsations provides a

⁷⁰Program note to the Nonesuch recording 79047 of Carter's Piano Sonata (1948) and *Night Fantasies* (1980), dated September 30, 1982.

⁷¹Schiff, *The Music of Elliott Carter*, 21.

clear and perceptible means of associating non-contiguous pitch events. Further study may suggest ways in which the quasi-metric layering of the *Enchanted Preludes* and Oboe Concerto examples can help to establish a similarly multi-layered approach to harmony.

Elliott Carter's recent compositions are among the most significant contributions to the repertoire of twentieth-century music. They embody a musical conception of unsurpassed vitality and charm, illuminated by the highest standards of compositional craft and an astonishing variety of rich and telling details. I hope the present work will help to clarify the relationship between technical means and expressive ends in Carter's recent works, and so contribute to our ongoing engagement with this remarkable music.

Appendix - Elliott Carter's Long-range Polyrhythmic Compositions, 1980-1989.

ABBREVIATIONS:

C = the cyclic duration of a polyrhythm.

P = the pulsation total of a polyrhythmic stream.

S = the speed of a polyrhythmic stream (measured in pulsations per minute).

T = the notated tempo.

B = the number of notated beats between pulsations.

NIGHT FANTASIES (12 Apr. 1980)

for piano

C = 20 minutes

P = 216 : 175

$S = 10\frac{4}{5} : 8\frac{3}{4}$

$B = \frac{5 \times T}{54} : \frac{4 \times T}{35}$

TRIPLE DUO (7 Feb. 1983)

for fl (+ picc), cl (+ eb cl, bs cl) / pno, perc / vn, vc

C = 20 minutes

P = 33 : 65 : 56

$S = 1\frac{13}{20} : 3\frac{1}{4} : 2\frac{4}{5}$

$B = \frac{20 \times T}{33} : \frac{4 \times T}{13} : \frac{5 \times T}{14}$

CHANGES (8 Sept. 1983)

for guitar

$$C = 6\frac{3}{10} \text{ minutes} \quad P = 75 : 56$$

$$S = 11\frac{19}{21} : 8\frac{8}{9} \quad B = \frac{21 \times T}{250} : \frac{9 \times T}{80}$$

ESPRIT RUDE/ESPRIT DOUX (2 Nov. 1984)

for fl, cl

$$C = 4\frac{2}{3} \text{ minutes} \quad P = 21 : 25$$

$$S = 4\frac{1}{2} : 5\frac{5}{14} \quad B = \frac{2 \times T}{9} : \frac{14 \times T}{75}$$

PENTHODE (9 June 1985)

for tpt, tb, hp, vn / fl, hn, perc, db / ob, tba, vn, vc / cl, bs cl, tpt, perc / bsn,
pno, perc, vla

$$C = 453,786\frac{2}{3} \text{ minutes (c. 315 days)}$$

$$P = 2,079,168 : 1,786,785 : 1,944,800 : 1,832,600 : 1,793,792$$

$$S = 4\frac{32}{55} : 3\frac{15}{16} : 4\frac{2}{7} : 4\frac{1}{26} : 3\frac{81}{85} \quad B = \frac{55 \times T}{252} : \frac{16 \times T}{63} : \frac{7 \times T}{30} : \frac{26 \times T}{105} : \frac{85 \times T}{336}$$

STRING QUARTET NO. 4 (June 1986)

for 2 vn, vla, vc

$$C = 23\frac{1}{3} \text{ minutes}$$

$$P = 120 : 126 : 175 : 98$$

$$S = 5\frac{1}{7} : 5\frac{2}{5} : 7\frac{1}{2} : 4\frac{1}{5}$$

$$B = \frac{7 \times T}{36} : \frac{5 \times T}{27} : \frac{2 \times T}{15} : \frac{5 \times T}{21}$$

A CELEBRATION OF SOME 100 X 150 NOTES (1986)

for orchestra

$$C = 2\frac{4}{5} \text{ minutes}$$

$$P = 56 : 45$$

$$S = 20 : 16\frac{1}{14}$$

$$B = \frac{T}{20} : \frac{14 \times T}{225}$$

OBOE CONCERTO (10 Oct. 1987)

for ob, orch

$$C = 18 \text{ minutes}$$

$$P = 63 : 80$$

$$S = 3\frac{1}{2} : 4\frac{4}{9}$$

$$B = \frac{2 \times T}{7} : \frac{9 \times T}{40}$$

ENCHANTED PRELUDES (13 Feb. 1988)

for fl, vc

$$C = 5 \text{ minutes}$$

$$P = 45 : 56$$

$$S = 9 : 11\frac{1}{5}$$

$$B = \frac{T}{9} : \frac{5 \times T}{56}$$

REMEMBRANCE (8 Mar. 1988)

for orchestra

$$C = 5 \text{ minutes}$$

$$P = 28 : 27$$

$$S = 5\frac{3}{5} : 5\frac{2}{5}$$

$$B = \frac{5 \times T}{28} : \frac{5 \times T}{27}$$

ANNIVERSARY (25 May 1989)

for orchestra

$$C = 6\frac{4}{11} \text{ minutes}$$

$$P = 56 : 45$$

$$S = 8\frac{4}{5} : 7\frac{1}{14}$$

$$B = \frac{5 \times T}{44} : \frac{14 \times T}{99}$$

List of Works Cited

- Bernard, Jonathan W. "The Evolution of Elliott Carter's Rhythmic Practice," *Perspectives of New Music* 26, no. 2 (1988): 164-203.
- Carter, Elliott. *The Writings of Elliott Carter*, ed. Else Stone and Kurt Stone. Bloomington & London: Indiana University Press, 1977.
- Derby, Richard. "Carter's *Duo for Violin and Piano*," *Perspectives of New Music* 20, nos. 1 and 2 (1981-82): 149-168.
- Edwards, Allen. *Flawed Words and Stubborn Sounds*. New York: Norton, 1971.
- Harvey, David. I. H. *The Later Music of Elliott Carter: A Study in Music Theory and Analysis*. New York and London: Garland, 1989.
- Mead, Andrew. "Twelve-Tone Composition and the Music of Elliott Carter." In *Musical Pluralism: Aspects of Structure and Aesthetics in Music Since 1945*, ed. Elizabeth West Marvin and Richard Hermann, forthcoming.
- Rahn, John. "On Pitch or Rhythm: Interpretations of Orderings Of and In Pitch and Time," *Perspectives of New Music* 13, no. 2 (1975): 182-198.
- Rosen, Charles. "The Musical Languages of Elliott Carter." In *The Musical Languages of Elliott Carter*. Washington: Library of Congress, 1984.
- Schiff, David. *The Music of Elliott Carter*. London: Eulenburg, and New York: Da Capo, 1983.
- _____. "In Sleep, In Thunder': Elliott Carter's Portrait of Robert Lowell," *Tempo* 142 (September 1982): 2-9.
- _____. "Elliott Carter's Harvest Home," *Tempo* 167 (December 1988): 2-13.
- _____. "First Performances: Carter's Violin Concerto," *Tempo* 174 (September 1990): 22-24.
- Scotto, Ciro. "Elliott Carter's *Night Fantasies*: The All-Interval Series as Registral Phenomenon." Unpublished paper presented at the Society for Music Theory conference, Oakland, CA, November 1990.

- Shreffler, Anne. "'Give the Music Room': On Elliott Carter's 'View of the Capitol from the Library of Congress' from *A Mirror on Which to Dwell*," unpublished English version of "'Give the Music Room': Elliott Carter's 'View of the Capitol from the Library of Congress' als *A Mirror on Which to Dwell*." In *Quellenstudien II*, trans. and ed. Felix Meyer (Winterthur: Amadeus, 1993): 255-283.
- Warburton, Thomas. "A Literary Approach to Carter's *Night Fantasies*," *The Music Review* 51, no. 3 (August 1990): 208-220.
- Weston, Craig Alan. "Inversion, Subversion, and Metaphor: Music and Text in Elliott Carter's *A Mirror on Which to Dwell*." D.M.A. diss., University of Washington, 1992.