

INFORMATION TO USERS

This was produced from a copy of a document sent to us for microfilming. While the most advanced technological means to photograph and reproduce this document have been used, the quality is heavily dependent upon the quality of the material submitted.

The following explanation of techniques is provided to help you understand markings or notations which may appear on this reproduction.

1. The sign or "target" for pages apparently lacking from the document photographed is "Missing Page(s)". If it was possible to obtain the missing page(s) or section, they are spliced into the film along with adjacent pages. This may have necessitated cutting through an image and duplicating adjacent pages to assure you of complete continuity.
2. When an image on the film is obliterated with a round black mark it is an indication that the film inspector noticed either blurred copy because of movement during exposure, or duplicate copy. Unless we meant to delete copyrighted materials that should not have been filmed, you will find a good image of the page in the adjacent frame. If copyrighted materials were deleted you will find a target note listing the pages in the adjacent frame.
3. When a map, drawing or chart, etc., is part of the material being photographed the photographer has followed a definite method in "sectioning" the material. It is customary to begin filming at the upper left hand corner of a large sheet and to continue from left to right in equal sections with small overlaps. If necessary, sectioning is continued again--beginning below the first row and continuing on until complete.
4. For any illustrations that cannot be reproduced satisfactorily by xerography, photographic prints can be purchased at additional cost and tipped into your xerographic copy. Requests can be made to our Dissertations Customer Services Department.
5. Some pages in any document may have indistinct print. In all cases we have filmed the best available copy.

University
Microfilms
International

300 N. ZEEB RD., ANN ARBOR, MI 48106

8212189

Elliott, W. Neil

GRAMMATICAL NUMBER

City University of New York

PH.D. 1982

**University
Microfilms
International** 300 N. Zeeb Road, Ann Arbor, MI 48106

Copyright 1981

by

Elliott, W. Neil

All Rights Reserved

Grammatical Number

by

W. Neil Elliott

A dissertation submitted to the
Graduate Faculty in Linguistics in
partial fulfillment of the require-
ments for the degree of Doctor of
Philosophy, The City University of
New York.

1981

© Copyright by
W. Neil Elliott
1981

This manuscript has been read and accepted for the Graduate Faculty in Linguistics in satisfaction of the dissertation requirement for the degree of Doctor of Philosophy.

1/28/82

Robert W. Fing Jr
Chairperson of Examining Committee

28 January 1982

Andrew Branski
Executive officer

D. Terence Langendoen

Edwin Williams
Supervisory Committee

The City University of New York

Acknowledgements

Acknowledgements offer the possibility of exposing to view the personal relations underlying the work that follows. They reveal, if only cryptically, a vitality well beyond the reaches of the work's form. It is the intellectual and emotional generosity of the people involved that have made the effort worthwhile to me. Towards them my gratitude is extended.

There is, first, the core of people most essentially responsible for the intellectual, physical and administrative completion of the dissertation, my committee, Robert Fiengo D. Terence Langendoen, and Edwin Williams. For what's good in what follows and the elimination of much that was worse than it is, these three deserve much thanks. Edwing has made influential contributions in suggestions for additional readings, provoking criticism and intriguing discussion of alternatives that would have never occurred to me. Terry has been a tireless reader of the reams that I produce, lending encouragement and critical support at every step. For Bob, I reserve a very special gratitude to which I will return.

Official responsibilities aside, I think it is indicative of the wealth and health of linguistics as a discipline that I count these people as friends as well as professional colleagues. And, of course, other friends with less official engagement also deserve thanks for playing many roles.

There are people who have put up with a lot. Two of

them are Robert May and Ken Safir. Robert May has helped me untangle confusions that would be opaque and inaccessible to someone less caring. In Ken Safir, I discovered someone who was willing to admit misgivings similar to my own when no one else would lay claim to them. In both, I find an emotional quality as touching as contact with their intellects is sharpening.

I learned at CUNY and MIT to rely on many people and I believe that reliance has been richly rewarded. Hagit Borer, Nina Hyams, Oswaldo Jaeggli, Carmen Picallo, and Timothy Stowell have taught me much about the free exchange of ideas involved in intellectual endeavor. They often had the patience to work against my own reticence. To the reader, the result of the exchange will only be partially evident in references, adoptions, borrowings, and influences. Without their criticisms, suggestions and ideas the work would have been impossible. I want it to be clear to these that my thanks is for something far more subtle than will ever appear on a page.

Josef Aoun, Ed Battistella, Adriana Belletti, Jan Edwards, Ann Farmer, Isabelle Haik, Jim Higginbotham, Shelley Lieber, David Pesetsky and Eric Wehrli have all provided significant help with many of the ideas herein. I thank each of them for their willingness to discuss with me their thoughts. To Ann, I owe a special debt for introducing me to the day-to-day functioning of the MIT department.

My experience with the Department of Linguistics and

Philosophy at MIT has been one of unstinting generosity. In particular, Professor S. Jay Keyser has used his considerable skills to smooth the way into linguistics for me. Professor Noam Chomsky has given his time, critical mind and teaching. It would be extremely difficult to repay what this department has freely given.

CUNY has taught me the value of an education and more than a few educational values, among them open admissions. The policies and staff of the Linguistics Department opened to me a life that would have been otherwise impossible.

The initiation into a life I wouldn't have thought possible brings me back to Bob Fiengo and links me also to thanks owed to persons in my past. I could have had no better first teacher than Bob. His energy in the classroom was inviting, propelling. I wanted to see the forms and he placed them on a chalkboard in trees. I was dazzled. Bob has to be thanked for less galvanizing performances as well. He has read it all, from the roughs of the first syntax paper through the drafts and final product of the dissertation. He has, in fact, read it several times. He has carefully criticized every bit. He has had his hand in at every level; he has been through every scene. I'm sure he's been tired of it and bored with it at least as many times as I have. I had, as a relief, the luxury of complaining to him. But he never grumbled to me and he never failed to be encouraging.

As for other charismatic personalities, there are the poets who first showed me the work to be done in language.

George Quasha, Charles Stein, Franz Kamin and Robert Kelly all pushed me to experiment with words, although I doubt they had in mind the scientist I became.

Heasun Kim, Michael Stevens, Fred Katz, Geoffrey Nunberg, and Amy Daiuta have my gratitude for contributions to my life which do not overtly appear here.

S. Peter Turner and Sharon Klein are my closest friends. Saying that reveals very little of the massive part they have played in my completion of graduate school. But then there is nothing else to say that would. Thanks is a far too miniscule word to express what I feel for their participation.

Marcia Lind has to be thanked for understanding the spiritual effort involved. She knows I went from holy roller to buddhist poet to transformational grammarian. She has the perceptiveness to realize it is all the same and the graciousness of not always saying so. She stuck it out, criticizing and caressing, cajoling and commending, through the best and worst of it. She taught me respect of the life of the intellect and engaged me in the life of emotions.

Finally, there are some remarkable members of the staff of the Broome Street Bar, Steve, Jeff, Jimmy, Susan, Kitty, John, Marty, Gwynne, Adrian, Lou, David and Kevin. They, on occassion, held up my head when I couldn't hold it up myself.

To all these, I express my deepest gratitude.

Table of Contents

Chapter I: An Introduction to Grammatical Number 1
Chapter II: Paradigm and Number 34
Chapter III: Number and Agreement 57
Chapter IV: Agreement and Interpretation 127
Bibliography 147

Chapter I

An Introduction to Grammatical Number

The expression of number in natural language is a rich source of data for research into the relationship between sound and meaning. Inflectional languages illustrate the point with the commonest of data. In the pair in (1), two facts stand out.

- 1)a The rock is heavy
 - *The rock are heavy
- b *The rocks is heavy
 - The rocks are heavy

First, the strings exhibit regular morphological alternations, *rock* ~ *rocks* and *is* ~ *are*. Second, the sentences contrast in meaning. The sentence in (1)a is true if and only if the predicate, "is heavy," applies to an individual rock. The same predicate in (1)b must denote a property of more than one rock if (1)b is true. Observing further, one discovers that the morphological alternations noted in (1) are regularly, although not unexceptionally, associated with the cited semantic contrast. Generalizing, English expresses differences in number by the device of morphological alternation in sentences.

The thesis which follows is an investigation into how the relation captured in the generalization above can best be expressed in a theory of transformational grammar.

The applicability of transformational/generative theory is evidenced by the fact that the expression of
- number in an inflectional language is subject to formal

constraints. For instance, a speaker of English knows that the plural form of a nominal is derived by the suffixation, but not the prefixation or infixation, of a plural marker. Among many others, Fiengo (1980) and Fiengo and Battistella (1980) observe that the generalization in (2) predicts the morphological properties of number inflection in English.

2) All inflectional affixation is suffixation

If (2) is correct and the further assumption that S-structure is the input of morphological rules is maintained, then the operation of the rule of suffixation expressing (2) is conditioned by the formal properties of S-structure.^{1,2} Because number inflection is a product of suffixation, it follows that syntactic properties condition the distribution of number inflection.

Other common examples attest to the syntactic nature of restrictions on the distribution of number inflection. Compare the examples in (3) with their counterparts in (1).

3)a *The rock are heavy

b *The rocks is heavy

The result of inflecting a verb for number in a way which does not agree with its subject NP is ungrammaticality. Evidence that the facts cited derive from properties of sound or meaning is lacking. For instance, Hale (1973) argues that in Warlpiri, where there is some evidence that agreement is a phonological copying rule, the cost to the grammar is prohibitive in comparison to a syntactic rule. As will be seen below, a semantic account of agreement can be given. But the semantic account fails for certain exceptional cases that

are otherwise regular with respect to agreement facts. I conclude that theories of sound or meaning do not predict the examples in question. At least part of what a speaker knows about the expression of number in English is represented in a theory of syntactic form. I will argue further that the theory of form is made explicit in an application of current syntactic theory in the framework of EST.

The facts demonstrate that a discussion of grammatical number requires attention to at least two components of a derivation under a transformational theory of linguistic form. In the segment of a derivation resulting in phonological outputs, grammatical number has a variety of inflectional reflexes. The alternations between "rock" and "rocks" and "is" and "are" give good examples. Elsewhere, in the interpretive component of a derivation, grammatical number determines semantic phenomena, as the contrast in meaning observed above shows. For ease of reference, I will call the subtypes of grammatical number inflectional number and semantic or interpretive number, respectively.

Consider the following account of the distribution and interpretation of number marking in inflectional languages. The syntactic feature, [α NUM(BER)], is generated in a base constrained under X-bar theory by the rules in (4).³

4) $XP \rightarrow \dots X \dots$; $X \rightarrow \dots X^{\circ} \dots$

The hierarchical framework determined by (4) is categorially specified by the lexical insertion of categorial and inflectional features, [$\pm N, \pm V, \pm NUM, \dots$], of items listed in the lexicon.⁴ Given that X° may be realized by any combination

of features, (4) predicts that number is a syntactic feature of every category. Let $\{\Delta', \Delta'', \dots\}$ be a set of phonological matrices of inflectional morphemes and " Δ " a cover symbol for any member of the set. Then (5) implies that the morphological distribution of number number inflection is determined by the feature, $[\alpha\text{NUM}]$, under the generalization in (2).

$$5) [\pm N, \pm V, \alpha\text{NUM}, \dots]^{\circ} \rightarrow \dots \Delta$$

Supposing that the domain of possible instantiations of α is "+" or "-"⁵ and that denotations fall into two subclasses, individuals or pluralities,⁶ (6) represents the rule of semantic interpretation, where $[\text{+IND}(\text{INDIVIDUAL})]$ is an individual and $[\text{-IND}]$ is a plurality.

$$6) [\alpha\text{NUM}] \rightarrow [-\alpha\text{IND}]$$

In the framework of EST, derivations exhibit the form illustrated in (7).

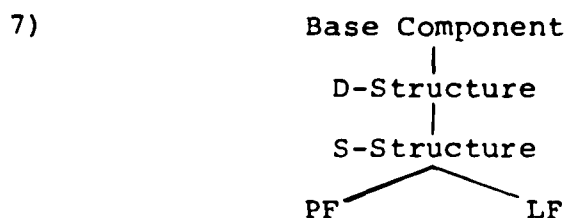

"PF" stands for some level or levels of phonological representation; similarly, LF, for Logical Form (in the technical sense of Chomsky (1975)). Under the conception of derivation shown, (4) will apply to derive D-structure phrasemarkers.

(5) will appear on the left in derivations to PF and (6) will apply on the right to yield semantic interpretations based on LF. In practice, the example in (1)a will be assigned the D-structure in (8), neglecting for a moment the details of lexical insertion.

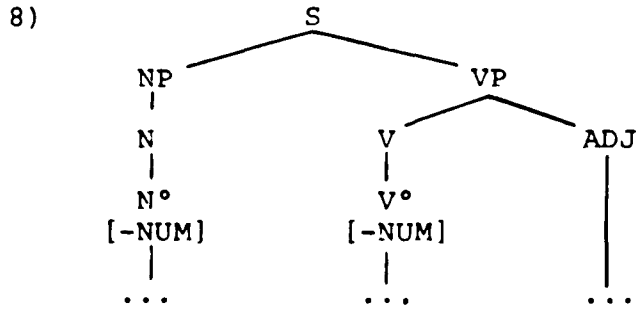

Assuming no rules apply between D-structure and S-structure, (8) will be the input to derivations to PF and LF. The derivation to PF, resulting from the application of (5), yields (9).

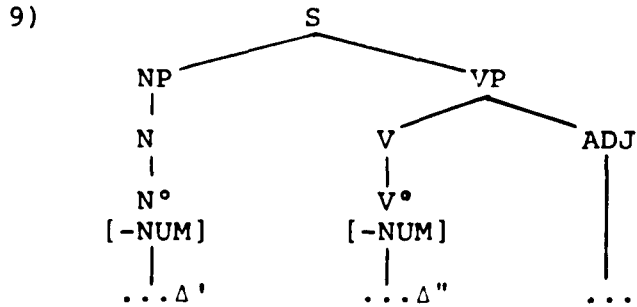

(8) is also the input to rule (6). The product is (10).

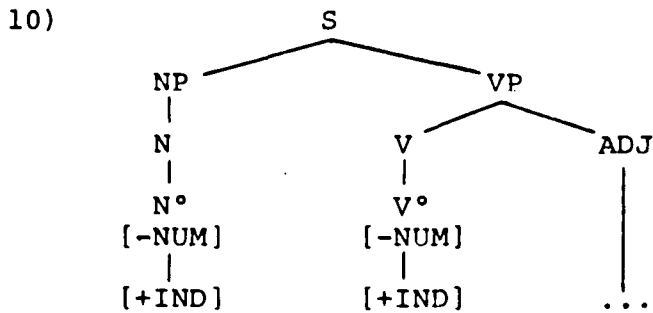

The structures in (9) and (10) will be associated with (1)a as its phonological representation and logical form respectively.

The unrestricted application of rules (4) through (6) raises one immediate problem and suggests a further question for investigation. The problem is the overgeneration of the structures in (11).

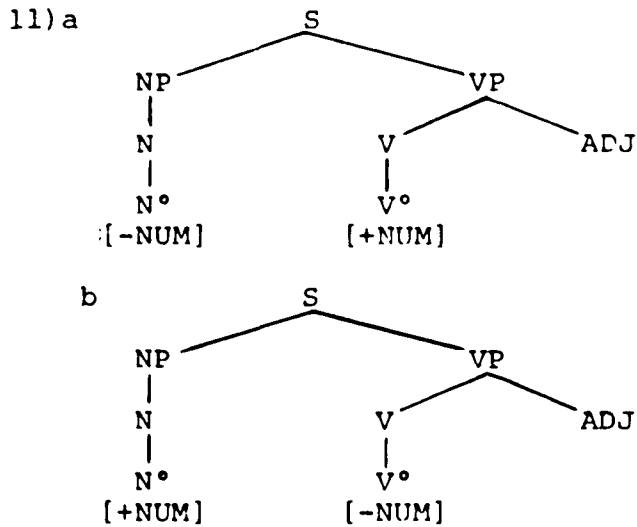

But the phrasemarkers in (11) permit the derivation of PF's and LF's for (3)a and b. Hence, if a syntactic account of the deviance of the examples is desired, (11)a and b must be ruled out by some further restriction to syntax.

Formally, the problem of overgeneration is not difficult to solve. A filter of the form in (12) is adequate to the task.

- 12) *... [_{N°} ...] ... [_{V°} ...] ...
 [_αNUM] [_{-α}NUM]

Of course, (12) is neither entirely explicit nor completely general in its formulation. For one thing, it does not apply to any arbitrary noun/verb pair. It applies only where the constituents mentioned bear a particular grammatical relation, at least in a nontechnical sense. The noun in (12) must be the subject of the verb or, more accurately, the subject of the sentence which contains [_{V°} ...] as the head of its verb phrase. (12) also fails to be sufficiently general. As Moravcsik (1978) observes, agreement occurs between nouns and almost every other kind of constituent including "definite

article, indefinite article, possessive adjective, quantifiers, numerals, descriptive adjectives, appositive adjectives, relative pronouns (all of these with their head noun); verb (with its subject and complements); anaphoric pronoun, reflexive pronoun, reciprocal pronoun (with their antecedents); possessed noun (with its possessor)" (pp. 364-365). Moravcsik's list includes constituents from every category described by the features, [$\pm N, \pm V$]. (13) is the appropriate revision of (12) with the proviso that X° need not be to the right of N° .

13) *... [N° ...] ... [X° ...] ...
 [αNUM] [- αNUM]

Nor can the application of (13) be determined only by grammatical relations like "subject-of." Some more general grammatical relationship(s) must be proposed to determine the elements of agreeing pairs. And as for the nominal term in (13), I restrict my investigation to constituents which agree with the head of a NP.⁷

The agreement filter raises a number of questions similar to the problem of the relation of the pair (N°, X°). Among them is the question of the level of application for (13). I have already briefly suggested that (13) is not a phonological filter; it does not depend on phonological identity. Perhaps (13) applies at LF or later. In fact, if agreement can be determined by semantic rule, (13) need not be stated in the syntax at all. The distribution of number inflection will then be determined by the highly restricted theory of syntax expressed in (4) through (6) and overgenerations will be discarded by the autonomous mechanism(s) of semantics.

It is tempting to view agreement as a formal reflex of predication. The phenomenon is commonplace between verbs (predicates) and (a subset of) their arguments. The account is obviously easy to extend to adjectives. And if Frege's (1950,1952) hypothesis that specification of quantity and definiteness is the result of a second-order predication is accepted, the possibility of extending the semantic account to articles, quantifiers and numerals is expected.

A semantic account of agreement requires me to be more explicit about what the structure in (10) represents and returns us naturally to the question raised earlier about the plausibility of interpreting [α NUM] in nonnominal contexts. The following sketch of an explication is the one which I will consider but other alternatives obviously exist.⁸

Suppose that at some cognitive level, grammatical or extragrammatical, NP's are decomposed into descriptions. In general, a description is a complex denoting term consisting of operators binding variables in the arguments of predicates. For example, the subject NP in (1)a, "the rock," is analyzed into the term in (14).

14) [_{NP} the x:x is a rock]

(15) gives a rough formalization (following Higginbotham and May (1978)) of the rule involved.

15) [_{NP} SPEC ... N° ...] [_{NP} SPEC x:x is a(n) N°]

Under an interpretation, the predicate is assigned a domain and the operator, "the x," requires that the entire description map onto a unique object, in this case, a unique rock,

if the proposition containing the description is to be true. Otherwise, the proposition expressed by (1)a will be false.

Given the theory of descriptions sketched, the semantic contribution of the feature, [α IND], can be described. I propose that [α IND] be interpreted as a condition on the domains of predicates. Consider a logical predicate, P. Under an interpretation, it is assigned as its extension a set of objects under no particular restrictions. P applies to each object in its domain and the quantities of those objects to which it applies are determined by other aspects of logical structure. My claim is that, by comparison, grammatical predicates contain more structure than P, which can be represented roughly as in (16).

16) [_{NP} the x:x is a [_{N^o} rock]]
 [+IND]

The presence of [+IND] restricts the domain of the predicate, "is a rock," to individuals. The subject of (1)b could be represented as (17) indicating the restriction of the domain to subsets containing more than one rock.

17) [_{NP} the x:x is a [_{N^o} rock]]
 [-IND]

In the system illustrated, the semantic contribution of [IND] can be characterized as an operation on the domain of a predicate which partitions the domain exclusively into individuals or pluralities. I will assume that the operation described is compositional. Thus, an NP marked for singular must denote individuals and a plurally-marked NP, pluralities.

Consider then the structure in (9). Given the unrestricted operation of the rules (4) through (6), the feature

[α IND] is assigned to both a nominal and a verbal construct. Again suppose that at some level of representation VP's are predicate expressions. If, as I have hypothesized, [α IND] represents an operation on the domain of a predicate, then nothing stands in the way of interpreting [α IND] in VP. The rule involved will see VP's logical structure as a predicate rather than its grammatical structure as a VP. For example, in (1)a the VP will contain the feature [+IND] as represented in (10). The semantic content represented by [+IND] combines with the predicate expression to indicate that the domain of "is heavy" is restricted to individuals.

So far, so good. The domain of the predicate expression "is heavy" is restricted to individuals and the subject expression, "the rock," picks out an individual in that domain if the proposition expressed by "the rock is heavy" is true. Furthermore, the deviance of the examples in (3) falls out as a consequence from one perspective. For instance, in (3)b, the inflectional marking of the VP, "is heavy," is interpreted as meaning that the domain of the predicate expressed by the VP consists only in individuals. But the subject picks out a plurality. A general and independently motivated semantic condition on the self-identity of arguments is violated. The structure of the predicate requires that its argument be an individual. But the denotation of the NP in the argument position is a plurality, i.e., a nonindividual. However, no argument may be both an individual and a nonindividual simultaneously without entailing a contradiction.

There are two major problems with the semantic theory

of agreement. The first is obvious asymmetries between predication relations and agreement relations, although how these asymmetries exhibit themselves is dependent on one's definition of predication. The second is the lack of one-to-one correspondence between the inflectional properties of number which determine agreement in natural language and the principles of numerical identity which govern relations between arguments and predicates.

While the existence of a predication relation between two agreeing constituents may be necessary for agreement to occur, it is certainly not sufficient. That is, agreeing pairs are only a subset of the pairs related by predication, under one definition of that relation. A plausible semantic theory implies that for some n -ary predicate ($n \geq 1$), each of n arguments is semantically related to the predicate by predication. For example, in "the man hit the ball," both "the man" and "the ball" are related to "hits" by predication. For English, the subject, but no verbal complement, agrees with the verb. The example demonstrates that only a subset of argument/predicate pairs in any sentence exhibiting nominal/verbal agreement show agreement relations.

Williams (1980a) theory of predication defines the relation more restrictively as the coindexing between a predicate and its external argument. While the identification of agreement and predication under Williams' definition makes the right predictions about subject/object asymmetries in agreement in English and other languages, as well as predicting subject/predicate nominal or adjectival agreement and

agreement in control contexts, it fails to account for object/verb agreement in others (e.g., Warlpiri). Thus, more restricted accounts of predication appear not to cover some obvious cases of agreement and the error observed above is reversed.

Returning to the empirical content of the second objection, many researchers have observed evidence contrary to the one-to-one hypothesis. I wish to make only limited observations of facts which falsify the thesis that [α NUM] and [α IND] are related by one-to-one correspondence.

Consider the examples in (18).

18)a The sand is wet

b The scissors are on the table

Taking (18)a first, on the semantic theory so far elaborated, the deviance of (18)a is predicted counter to intuition. The presence of [+IND] in the semantic representation of the predicate, "is wet," restricts its domain to individuals. However, "the sand" denotes no individual.⁹ The condition on identity of arguments is violated and presumably (18)a ought to be as bad as the examples in (3). The example in (18)b is simply ambiguous. The datum shows that [+NUM] in some syntactic structures maps onto either individuals or pluralities at semantic representation. If agreement features determined the identity of arguments as the theory under investigation suggests, it would be predicted that only plural arguments could be assigned to (18)b. Hence, the facts invalidate the hypothesis that inflectional number and semantic number are in one-to-one correspondence.

Because inflectional number does not map one-to-one onto semantic number and agreement requires inflectional identity, a theory which projected agreement in terms of semantic properties alone would still have to account for the distribution of inflectional number by other rules. I conclude that the semantic account of agreement is at best incomplete. The agreement filter is required in a theory of grammar. Note, however, that it cannot be concluded from my arguments that agreement is not a right-side rule.

The theory that agreement is a syntactic reflex of predication appears, from the facts cited, problematic. In fact, given the autonomy thesis, it could turn out that number inflection and the distribution of agreement pairs is arbitrary with respect to predication relations or even the abstract properties and relations like subject-of, direct-object-of, etc. However, such arguments would turn on the formalization of predication relations, as I have shown. Of course, some theory of predication may, in fact, determine exactly the core agreement facts for natural language. In short, the major problem is to discover a formalization of predication relations relevant to the theory of agreement.

Taking up the topic in more detail, two opposed views can be delineated and evidence advanced. The first, which I will designate the paradigmatic perspective, urges that the inflectional realization of agreement is arbitrary and unpredictable in terms of any particularly deep properties of core grammar, although a better understanding of the internal properties and relations of paradigms might make a contribu-

tion to our understanding of language. The second hypothesis I will call for convenience the global view. The global view attempts to relate the distribution of agreement pairs in specific languages and crosslinguistically to highly abstract properties of syntactic representation.

Jespersen (1965) is one proponent of the paradigmatic perspective. He supposes that adjuncts of nouns are, in general, subject to agreement, but that the occurrence of inflectional marking is governed not so much by agreement as by properties internal to a paradigm, properties such as the availability of morphemes realizing abstract features of paradigmatic classification, suppletion and affixational processes, categorial variation in inflection, etc. On this view, the occurrence of agreement pairs is largely accidental, determined on the one hand, by extragrammatical factors such as expressivity and, on the other, by observation of superficial morphological identities.

At first glance, the facts lend plausibility to Jespersen's position. Suppose the observation of agreement/predication asymmetry is extended to other languages. Variation is extreme. Warlpiri, unlike English, is observed by Hale (1973,ms.) to exhibit a verbal auxiliary which agrees with objects and indirect objects as well as subjects. At the other extreme, Korean shows no nominal/verbal agreement at all. French shows object agreement with past participles under very restricted circumstances. The Romance languages and English have other relevant differences. In French, Spanish, Italian, etc., adjectives agree with the nouns they

modify but in English they do not. Specifier systems in Romance show more inflectional evidence of agreement: in English, morphological alternation is restricted to demonstratives. Other examples are always at hand in this domain.

Jespersen (1965) proposes to account for the welter of linguistic variation by a functional principle. He assumes an ideal model of language under which language change neutralizes formal distinctions which do not contribute to the expression of meaning. His argument assumes the principle that inflection for number is meaningless outside of nominal paradigms. Accordingly, linguistic "progress" reduces number inflection outside of nominal categories. Asymmetries of agreement and predication within language and crosslinguistic differences in inventories of agreeing pairs are explained by the deterioration of inflectional paradigms due to a vague principle of linguistic change determined by semantic properties.

Internally Jespersen's view faces at least one problem. If an ideal language is one which neutralizes all non-expressive formal distinctions, the question must be asked why number inflection and a rule of concord came into existence at all in the Romance languages. One possible answer is teleological. It assumes, following Saussure (1959), that language emerges out of undifferentiated speech and moves towards ever more perfect reflections of itself, the most perfect being absolutely efficient in expressivity. On this view, inflection and concord are just early and bad experiments in primitive speech patterns having little to do with

the essential nature of the sound-meaning relation. Another answer is to assume that the protolanguage from which Romance languages evolved was based on principles of expressivity which entailed the meaningfulness of agreement, i.e., the protolanguage itself more closely approximated the ideal. But with time, the principles of expressivity changed and thus deterioration of inflection and progress towards the new ideal state began.

The existence of languages like Warlpiri can be cited as evidence for the latter point of view. In Warlpiri, it appears that agreement serves crucial interpretive functions. Hale (1973) cites the following facts about number related phenomena for the language. Basically, sentences contain a verbal auxiliary consisting of tense and agreement features. The auxiliary agrees with subjects, objects and indirect objects. The nominal paradigm is distinguished into one singular and three nonsingular classes. The three nonsingular cases are plural, dual, and paucal plural ("few"). The paradigm is realized by the presence of number inflection on the determiner. For example, there are the forms shown in (19).

- | | | |
|------|------------------|---------------------------------|
| 19)a | /njampu/ | "this singular," "these plural" |
| | b /njampu-tjara/ | "these dual" |
| | c /njampu-patu/ | "these few" |

Head nouns are only rarely inflected for number. Observing (19)a, it must be noted that the nominal paradigm does not distinguish between the singular and the regular plural. Yet sentences of Warlpiri containing an NP with the determiner in (19)a are not regularly ambiguous between singular and plural.

Agreement is the crucial factor. Hale observes that the auxiliary exhibits the inflection shown in (20) for the third person.

20)a	∅	singular
b	/-pala/	dual
c	/-lu/	plural

If a speaker wishes to express a plural idea in some argument place, then the auxiliary must bear the plural inflection in the position corresponding to that argument. In short, it is the agreement properties of the auxiliary inflection that determine semantic interpretation. What the evidence shows is that it is possible for agreement to have the expressive function which Jespersen presupposes.

Even granting the interpretation of the evidence from Warlpiri, it emerges that the thesis minimizes the facts as linguistic evidence. The difference between Warlpiri inflection and French inflection is that the former reflects an ideal expressive system that the other does not. The distinction is related to mysterious differences in expression. Assuming the autonomy thesis is correct, the explanation gives no insight into language whatsoever. I believe it is more likely that Hale's (ms.) view is correct. The relation of inflection to interpretation in Warlpiri is determined by deep syntactic properties of the language which Hale shows to be highly divergent from configurational languages like French.

More serious problems attend Jespersen's thought on language and expressivity. It is based on the Fregean perception of imperfection in the natural language. Frege (1952)

laments certain logical mistakes which "arise from an imperfection of language, from which even the symbolic language of mathematical analysis is not altogether free" (p. 70). Jespersen adds the suggestion that language is self-therapeutic rather than accepting the artificial revamping of conceptual notation which Frege counsels. The deep mistake here is the normative assumption that language, at least at some level of representation, ought to be in one-to-one correspondence with meaning.

I have already shown the one-to-one thesis to be empirically lacking. Now it seems that insisting on its normative truth leads to no very insightful conclusions about the properties of natural language.

Leaving off criticism of underlying assumptions involved in Jespersen's paradigmatic approach, I think the facts show it to be empirically deficient as well or at least permit an optimistic approach to a global hypothesis.

For instance, Moravcsik (1978) cites evidence that points beyond paradigmatic generalizations about number inflection. She observes that language internally number inflection in agreeing constituents varies not only with respect to categorial properties but is conditioned by other properties of syntactic representation. Evidence is given that agreement varies in terms of whether an agreeing constituent is internal or external to the NP whose head it agrees with.

An illustrative example can be given from French by extending Fauconnier's (1979) observation of the interaction of quantifier float and agreement. Compare the examples in

(21) and (22).

- 21)a *Les hommes sont intelligent
- b Les hommes sont intelligents
- 22)a *les hommes intelligent
- b les hommes intelligents

The parallel patterns of contrast between the pair in (21) and the one in (22) shows that agreement facts for predicate adjectives and NP-internal adjectives is the same for the examples. The pair in (23) is distinct from those in (21), (22) in lacking any contrast in grammaticality.

- 23)a Les hommes sont chacun intelligent
- b Les hommes sont chacun intelligents

The predicate adjective need not be inflected for number in relation to the subject which it modifies, as (23)a shows. Nor is it uninflected in (23)a; it is marked for singular agreement with the floated quantifier. Fauconnier goes on to analyze the derivational source of the sentences in (23) but I wish to make a different point. Consider the data in (24).

- 24)a *chacun des hommes intelligent
- b chacun des hommes intelligents

One explanation of the contrast between the pairs in (21) and (23) can be traced to a distinction in possible "antecedents" for adjectival agreement. In (21)a and b, there is a single source for the agreement features morphologically realized in the adjective, *viz.*, the subject NP. In the (23) examples, there are two possible antecedents to agreement, the subject NP and the floated quantifier. The examples in (24) show that it is not just the presence of two possible

antecedents in the construction which explains the lack of contrast between (23)a and b. (24)a and b contain similar possible antecedents, but contrast nonetheless. When the possible antecedents to agreement and the agreeing constituent are all NP-internal, the adjective must agree with the head noun of the construction and not the quantifier. But when the possible agreement antecedents and the agreeing constituent are contained in some other category, in this case, S, possibilities for agreement are less restricted. In general, the internal structure of NP places restrictions on agreement which go unobserved in NP-external contexts.

Moravcsik also points out a number of crosslinguistic regularities which she formalizes as descriptive universals. As examples, consider (25) and (26) (her (1),(2), p. 364).

- 25) There is no language which includes sentences where the verb agrees with a constituent distinct from the intransitive subject and which would not also include sentences where the verb agrees with the intransitive subject.
- 26) There is no language which includes sentences where the verb agrees with the dative complement but which includes no sentences where the verb agrees with the direct object complement.

(25) and (26) are generalizations which predict the occurrence of some classes of agreeing pairs from the existence of others within a language. Crucially, the classes of possibly agreeing pairs are determined by the grammatical relations of one member of the pair.

It is an open empirical question whether current theories of grammar can be elaborated to entail the descriptive universals suggested by Moravcsik. But an exclusively

paradigmatic approach cannot, in principle, be extended to cover such facts, if facts they are. While the paradigmatic theory can reveal useful principles of inflectional distribution in a particular category, it cannot describe the more abstract properties of the distribution of agreement pairs because it cannot express the notions of phrase boundary or grammatical relation.

Summarizing briefly, I have argued that any insightful analysis of number inflection and interpretation will have to set the parameters of investigation carefully. My sketchy review of the evidence indicates that the properties of core grammar determine the distribution of inflectional number. Trying to describe the distribution of inflectional number in a paradigmatic perspective alone fails to achieve coverage in an intriguing range of facts. Now I will sketch the possibility of an investigation based on a componential view of grammar which incorporates the autonomy thesis, the insights of the paradigmatic approach to number inflection and a global perspective on the properties conditioning the occurrence of agreement pairs in language.

From the perspective of elaborating more detailed theoretical possibilities in the framework of EST, it is interesting to focus on one of Jespersen's claims. He asserts that number inflection is meaningful only in nominal paradigms. Evidence for the claim is not lacking.

The data I now present show that both nominal and verbal paradigms have numerical properties at the level of semantic representation. But it also reveals that number

inflection is a determinant of those properties only in nominal categories. If inflectional number determines number interpretation in noun categories and number interpretation is independent of inflection in verbal categories, it follows that the grammatical number is interpreted only in NP's.

It is fair to say that at the level of semantic representation the properties of number interpretation are more various than the simple distinction between singular and plural. In Warlpiri, a language not unusual in the following respect, I have already cited a three-way contrast opposed to the singular: dual, paucal plural and plural. Moravcsik (1978) concludes from her observations in the area that

all number distinctions come down to distinctions between numerated and non-numerated plurals, duals, trials, and collectives--all opposed to singular (p. 349).

Other interesting properties of number have been identified in the literature and receive frequent comment. Among them are identity, the collective/distributive distinction and the mass/count distinction.

The actual semantic status and independence of each property mentioned has been thoroughly discussed in both the philosophic and linguistic traditions. I will examine some of the issues raised in more detail later on. For now, I wish only to make the point that the phenomena which the concepts above describe are exhibited in nonnominal as well as nominal categories.

Consider, for instance, the singular/plural opposition itself. The sentence in (27) may be more specifically paraphrased by (28)a or b.

27) Mary hit the ball

28)a Mary hit the ball once

b Mary hit the ball more than once

(28)a illustrates singularity in the verbal idea; (28)b, plurality. Fiengo (p.c.) remarks that, in general, the iterative interpretation of a verb can be considered its plural. That verbal meanings have identity criteria associated with number follows from the distinction between iterative and noniterative interpretations. Identity criteria for number are entailed by the singular/plural distinction; it is in principle impossible to distinguish one thing from more than one thing without criteria for identifying the thing. Or one action from another. Verbal ideas distribute as in (29).

29) John and Mary drove to Chicago

The sentence has two paraphrases shown in (30).

30)a John drove to Chicago and Mary drove to Chicago

b John and Mary drove to Chicago together

Or the meaning of a verb can be collective as in (31).

31) The men surrounded the house

Obviously, there is no distributive interpretation of (31) where each of the individual men surrounded the house. Finally, Pelletier (1979) observes, following Quine (1960), that the sortal/nonsortal distinction among properties closely parallels the mass/count distinction in nouns. In general, sortal properties individuate their domains while nonsortals do not. For example, consider the examples in (32) and (33).

32)a The ball is spherical

b The ball is red

33)a ?The Beaujolais is spherical

b The Beaujolais is red

(32)a is of lower acceptability than any of its companions. The contrast can be explained by supposing that the stuff denoted by "the Beaujolais" does not meet the conditions of individuation imposed by the predicate, "is spherical." The predicate, "is red," a typical nonsortal, individuates less rigidly, permitting its domain to contain things and stuff.

Although the independence of each of the phenomena exhibited is questionable, I think my initial claim that both nominal and verbal ideas contain parallel semantic structures for number is amply demonstrated. It is time to turn to the interaction of the properties displayed with inflectional number.

The demonstration that number inflection determines the number interpretation of just NP's for plurality, identity, distributivity, and countness/sortality is easily given. For instance, the examples in (34) alternate for inflectional number.

34)a The man chases the dog

b The men chase the dog

However, both sentences have the full range of paraphrases for number in the verbal idea. To clarify, (34)a expresses two propositions, one of which is true iff the man is presently chasing the dog, the one act reading. Or it is true iff there is an iteration of acts. The same is true of (34)b. However, the subject of (34)a is unambiguously singular: (34)b, univocally plural. The alternation in number

inflection determines an alternation in number interpretation for the subject but not the verb although the number properties available for semantic representation are the same in both categories.¹⁰

From the same examples the reader may, given my remarks on the relation of identity and plurality, construct an argument showing that number inflection determines the application of identity criteria only in nominals.

Nor are similar observations difficult to construct for distributivity and collectivity. (35) shows the requisite morphological alternation in noun and verb.

- 35)a The committee drives to Chicago on Tuesday
- b The members of the committee drive to Chicago on Tuesday

(35)a may be understood to mean each member of the committee drives to Chicago on Tuesday or the committee together drives to Chicago on Tuesday. Similarly for (35)b. But there is either a single committee or a plurality of committee members denoted by the subject noun dependent on inflection. The facts may be may be more completely grasped by comparing (36) and (37).

- 36)a ?The member surrounds the table
- b The members surround the table
- 37)a The committee surrounds the table
- b The committee surrounds the table

It is observed that (36)a is less acceptable than the other examples. The nondeviance of both members of the pair in (37) shows that "surround" is indifferent to the inflectional

number marking of its subject. The property of collectivity in its semantic structure requires a numerically appropriate subject uniformly throughout the examples thus accounting for the deviance of (36)a. While number inflection of the noun does determine its meaning in part, the numerical idea contained in the verb is unaltered.

Coming to the mass/count and sortality distinctions, I offer the sentences in (38) and (39).

- 38)a The rock is soft
- b The rocks are soft
- 39)a The mud is soft
- b ?The muds are soft

"Is soft" is a typical nonsortal predicate. it does not distinguish the individuating properties of the denotation of its subject. (39)b is deviant although, as has been frequently noted, the sentence can be assigned the paraphrase in (40).

- 40) Those kinds of mud are soft

In general, the application of plural inflection to a mass noun derives a plural kind term in semantic representation whether the noun is well-formed or not. Number inflection in the predicate "are soft" has no parallel consequences.

On the basis of the evidence, I conclude that inflectional number determines the semantic properties of interpretive number only in nominal categories. It remains only to formulate an expression of the generalization in the framework of EST.

In accord with the hypothesis that number marking is meaningful only in nominal categories, a more restricted

metatheory may be developed. Suppose that [NUM] is lexically specified only in the feature matrices of nouns. Lexical insertion into the phrasemarker underlying (1)a generates the structure in (41).

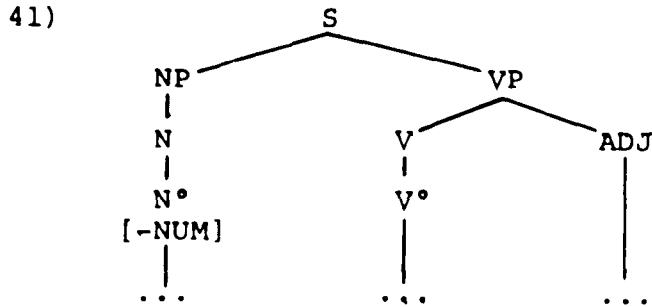

(41) underdetermines the distribution of inflectional number. The application of (5) to (41) derives (42).

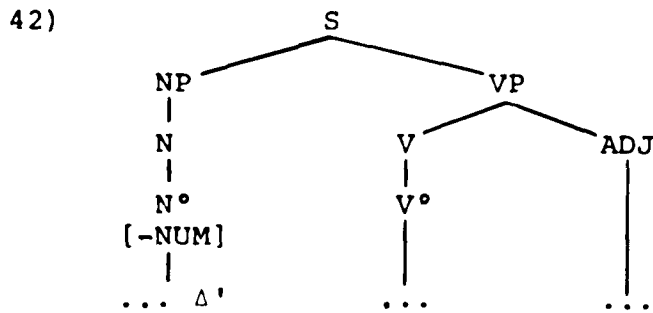

But (42) cannot underly (1)a since it entails that the verb will be uninflected for number. In a theory assuming lexical nouns as the source of base-generated grammatical number, the Agreement Filter must be revised to a copying transformation of the rough form in (43).

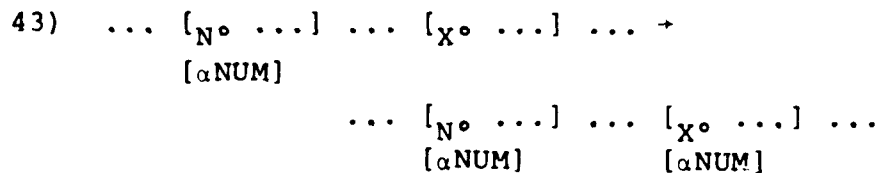

From (41), (43) yields the structure in (44).

that syntactic number determines semantic representation only in nominals can be expressed as a restriction of the level of application of the transformation. Recall the metatheoretical set-up in (7).

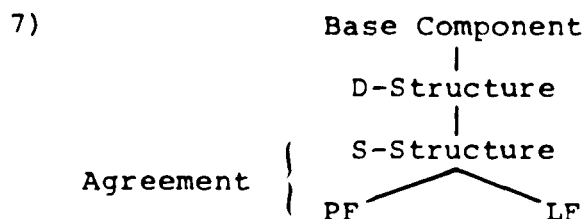

If it is supposed that Agreement applies in derivations from S-structure to PF, as shown, then it follows that inflectional number is invisible to interpretive rules operating on non-nominal structure. That is, (41) is the input to distinct derivations to PF and LF. No rule applies to (41) between S-structure and LF. Consequently, (41) determines the semantic representation of (1)a in accord with Jespersen's claim. Given that Agreement applies between S-structure and PF, the distribution of inflectional number is predicted correctly. The version of the autonomy thesis assumed (similar in most respects to that in Aoun (1979) and Fiengo (1980)) entails the relation of inflectional and interpretive number for which I have presented evidence.

One can imagine other metatheoretical possibilities. For instance, in recent expositions of EST under Government Binding Theory, renewed attention has been given to a collection of phenomena observed by Perlmutter (1972). In particular, discussion has focussed on the fact that Italian and Spanish permit phonologically null subjects while English or French require that subject NP's be nonnull. One line of

argument, e.g., Taraldsen (1978), claims that linguistic variation of the sort observed is a reflex of agreement phenomena.

If agreement is crucial to the description of the so-called PRO-Drop Parameter, a simple explanation of the difference between English and Italian follows from the form of derivations displayed in (7) and entailed by the assumptions discussed above. The agreement properties of Italian are such that interpretive principles applying at LF can read the inflection of the verb for nominal properties of the subject. Fitting a more formal description to the facts, suppose that agreement follows from the Agreement Transformation (43). Then the dissimilarity of English and Italian is entailed by a difference in the level of application of (43). In Italian, it is reasoned that the outputs of agreement must be available of LF. Contrastively, the products of (43) are inaccessible to rules operating at LF in English. If it is assumed that (43) is a rule applying between D-structure and S-structure in Italian and S-structure and PF in English, the distinction is a consequence of the form of grammar imposed by metatheory. Where S-structures are among the outputs of agreement, the required structures are available for interpretation and the language may have nonphonologically realized subjects. Where the outputs of Agreement are found exclusively at PF, rules of semantic interpretation cannot apply to verbal inflection (there is none to apply to) and null subjects are impossible. The grammar of English reflects the latter organization; Italian, the former.

Obviously, there are competing theories of the PRO-Drop parameter such as Jaeggli (1980) and others. I have shown, however, that EST permits formulations of the sound-meaning relation determined by a class of grammatical theories that are desirable in many respects. Evidence has been given that the distribution of both inflectional and semantic number is determined by the interaction of a number of abstract grammatical properties and relations expressible in EST. The metatheory admits of a parameterization which has been recently argued to be characteristic of explanatory linguistic theories. I conclude that EST is an apt representational idiom for the relation between sound and meaning expressed in grammatical number.

In succeeding chapters, I will discuss in more detail the issues touched on above. Chapter II will investigate the paradigmatic representation of number inflection, the morphological component and facts unaccounted for paradigmatic descriptions. Chapter III examines the principles determining agreement phenomena. A reprise consideration of the interpretation of number is contained in Chapter IV.

Footnotes

1. I follow current usage in distinguishing between surface structure and S-structure. Surface structure is some form of phonetic representation with labelled bracketing, i.e., phonological representation or PF. S-structure is the level of syntax, following Fiengo (1980) and others, determined by the interface of components mapping from D-structure to S-structure and from S-structure to PF or Logical Form.

2. Given the usual distinction between inflectional and derivational morphology, it should be pointed out that S-structures may be the input only to a subset of morphological rules, viz., rules of inflection.

3. I assume the general X-bar principle in (i) with two restrictions.

$$i) \quad X^n \rightarrow \dots X^{n-1} \dots$$

The first is that $0 \leq n \leq 2$. The second is that the material represented by "... " is either SPEC or the maximal projection of some category if nonnull where a maximal projection is X^2 . For orthographic convenience, I adopt for the remainder of the thesis the conventions in (ii).

$$ii) \quad X^2 = XP, \quad X^1 = X, \quad X^0 = X^{\circ}$$

4. Following Farmer (1980), Lieber (1980).

5. Coefficients of inflectional features may also be specified by integers in order to account for languages exhibiting more complex number distinctions such as duals, trials, etc. Cf. Chomsky (1965).

6. Cf. Higginbotham (1979b) for further comment on pluralities. I will make no argument as to the exact character of [-IND], assuming that it might include denotations of mass nouns as well as pluralities. Cf. Cartwright (1970,1975) for further comment.

7. Although Moravcsik (1978) comments that adverbs may agree with the constituents they modify, she cites no examples. Hence, it is impossible to determine from her work whether there are any cases of agreement where both members of an agreeing pair are nonnominal and neither is related by agreement to some nominal.

8. Cf. Lapointe (1980) for an extensive treatment of several kinds of agreement as conditions on well-formedness of logical form. To minimize terminological confusion, the reader should note that Lapointe treats case marking, subject/verb agreement, cliticization, and noun/modifier concord under the rubric of agreement. I treat a more restricted

set of cases as will be seen. However, his theory is not immune to the criticisms of the hypothetical sketch I provide above since he translates inflectional number directly into singular and plural variable types.

9. I am assuming, although controversially perhaps, a distinction between things and stuff which is reflected in semantic representations. But cf. references of fn. 6 for further comment.

10. Terry Langendoen (p.c.) observes that the examples in (34) need not be analyzed as being ambiguous under the paraphrases given in (i).

- i)a The man chases the dog at least once
- b The men chase the dog at least once

Presumably, the readings in (i) are simply vague between a single action and habitual action. My point, I believe, still stands. The verbal inflection does not determine verbal number.

Langendoen (p.c.) does, however, note a case in which inflection can be said to govern number interpretation of the verb. Consider (ii).

- ii)a We go to market Saturday
- b We go to market Saturdays

(ii)a has the paraphrases in (iii).

- iii)a We are going to market this Saturday
- b We habitually go to market on Saturday

(ii)b has only the paraphrase in (iii)b. Thus, the presence of plural inflection in the time adverb restricts the readings available to (ii)b. I have little to say about these cases other than to point out that while "Saturdays" functions as an adverb it may remain categorially a nominal. The facts are then consistent with my thesis.

Chapter II

Paradigm and Number

Overt expressions of number occur in two distinct contexts, nominal and nonnominal. In the chapter which follows, I examine in detail the differences in number expression in the two categories. From my observations will emerge some general facts. Within noun phrases, the distribution of inflectional number, [α NUM], is very complex. I will show that in NP's inflectional number has many properties exhibited in cooccurrence restrictions with other number-related characteristics of NP's like definiteness and quantification as well as agreement. The phenomena I have in mind are unlikely to be described as purely morphological or, more narrowly, inflectional and seem thoroughly interpretive in some respects. Contrasting nonnominal contexts, the distribution of inflectional number can be predicted by agreement with some related nominal and, more specifically in verbs, by interaction with closely related inflectional features like tense.

Before proceeding with an investigation of verbal number inflection, I would like to establish some theoretical parameters in which to embed observations. Rules of inflectional morphology are classically distinguished from rules of syntax such as Move α and rules of derivational morphology. In the case of the former distinction, rules of inflection account for syntactically conditioned properties of word formation exhibited in affixation. Rules of syntax, on the other hand,

account for the displacement of base-generated constituents. If affixes undergo similar displacement, as has been argued for Affix-Hopping, Subject/Auxiliary Inversion, etc., it can be hypothesized (as in Fiengo (1980)) that the displacement rule involved is formally distinct from Move α .¹ Chomsky (1970) gives the classical arguments for distinguishing inflectional from derivational morphology. The classical interpretations of the Lexicalist Hypothesis places derivational morphology in the lexicon and inflectional morphology in post-S-structure derivations to PR.

Others, for example, Williams (1981) and Lieber (1980), have argued that inflectional and derivational morphology should be collapsed into a single component. To recapitulate the specifics of Lieber's (1980) theory briefly, word formation is treated as a component of the grammar operating in the lexicon. Word formation derives from rules providing branching structures at word level representing hierarchical relations between stems or roots and affixes, insertion of lexical items into said hierarchical structures, and percolation of features controlled by several conventions.

To give a more concrete example, consider the inflection of a word from category C, where C represents a feature complex of at least $[\pm N, \pm V]$. Suppose the lexical listing for a word is (1).

1) $[\Delta, [+C, \dots], \Sigma]$

" Δ " is a phonological matrix; " Σ ," a semantic representation.

" $+C$ " represents a specification of the categorial features.

Following Lieber's theory, an inflectional affix has the form

in (2).

2) [Δ' , [$+$]_C___]_C, α NUM, ...], Σ']

In general, the reader will see that I have made standard assumptions (e.g., following Chomsky (1965)) about the schemata for lexical items. Δ and Δ' are phonological matrices; Σ , Σ' semantic representations (if any, a reasonable doubt in (2)). The second member of the triplets in (1),(2) is a matrix of syntactic features. The schemata show that stems and roots, (1), may be formally distinguished from affixes, i.e., affixes may subcategorize for position and categorial features of the stem to which they attach while stems do not subcategorize for properties of affixes.

Word formation for inflection occurs as follows. The hierarchical rules generate an unlabelled branching structure as in (3)a.

3)a

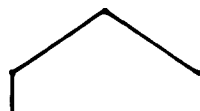

b

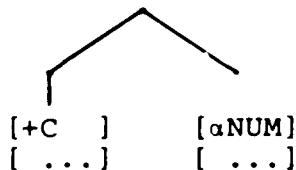

Insertion of lexical items results in (3)b. Percolation yields (4).

4)

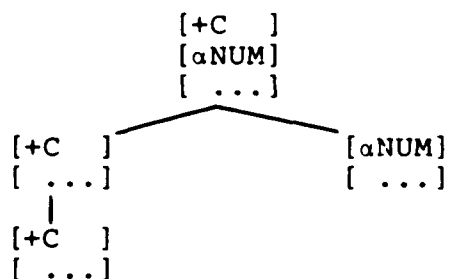

Because the entire process sketched in (3),(4) occurs in the lexicon, (4) is an output of the lexicon and like any other

lexical item is inserted into phrasemarkers by Lexical Insertion.

The theory sketched claims two advantages, one empirical and the other theoretical. Lieber (1980) shows that certain properties of derivational morphology depend on the inflectional character of the stems to which derivational morphemes are affixed. Hence, some statement of inflection must occur in the lexicon. Second, the theory eliminates the redundancy of feature specification between the hierarchical rules of the phrasestructure component and the syntactic feature matrices of lexical items. Farmer (1980), followed in great detail by Stowell (1981), proposes a categorially-neutral base component with rules of the form in (5).²

5) $XP \rightarrow \dots X \dots, X \rightarrow \dots X^{\circ} \dots$

As noted in Chapter I, the hierarchical rules in (5) are restricted under reasonably standard X-bar theory assumptions. Lexical Insertion is context-free. All features including [$\pm N, \pm V$] have their source in the lexicon. Lexical Insertion plus Percolation from the feature matrix of the head of a phrase determines the categorial signature of a hierarchical structure at XP and all levels intermediate between the phrasal and lexical levels.

Let us consider the inflection of verbs in more detail. Under the assumptions above, the only sense in which inflectional number is inherent in any lexical category is via affixation of an inflectional morpheme. For example, (6) shows the inflection of a regular verb, present tense.

6)a He/she walks

b They walk

"Walk" may be assigned the lexical listing (7)a; the inflectional affixes are given in (7)b and c.

7)a [walk, [+V,...], ...]

b [s, [+]_{V^o___}]_{V^o,}-NUM,...], ...]

c [∅, [+]_{V^o___}]_{V^o,}+NUM,...], ...]³

Given the lexical listings in (7) along with the process of word formation described in (3),(4), the third person singular form of the verb "walk" can be generated by the derivation in (8).

8)a

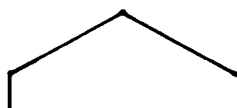

b

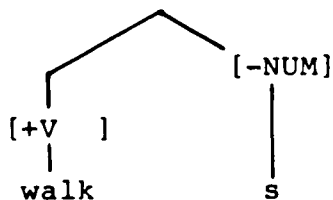

c

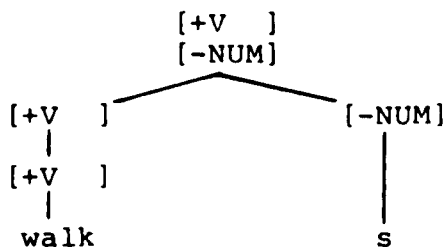

(8a) represents the operation of the hierarchical component; (8)b, the insertion of lexical material; and (8)c, the operation of the percolation rules according to conventions which I will describe in greater detail later in the chapter.

English offers a particularly limited perspective on inflection in verbal paradigms. To expand further on the view offered here, a consideration of Romance languages is in order. In French and Italian, for example, a subset of

of verbal participles are marked for number inflection in agreement with their subjects.

The first remark I want to make is that the participles concerned, in French, those associated with "etre" and for Italian, participial adjuncts of "essere," reveal nothing exceptional about morphological processes *per se*. In respect to morphological alternation itself, it is easy to lump "etre/essere" participles with adjectives.⁴ Inflectional processes for adjectives may be accounted for by the mechanisms I have already discussed. All that is necessary is to propose lexical listings for affixes as in (9).

9) a [-∅, [+]_{ADJ}____] _{ADJ}, -NUM, ...], ∅]

b [-s, [+]_{ADJ}____] _{ADJ}, +NUM, ...], ∅]

I use the notation "-s" as a symbol to distinguish (9) a and b orthographically. The orthographic "-s" is, in most phonological environments, realized as a null phonological matrix in French and Italian.

The forms in (9) do bring up one point. Like English, French and Italian verb paradigms show person and number marking for tensed verbs. For adjectives, however, marking is for number and gender but not person. Participles mark analogously to adjectives, not verbs. The trick is to ensure that participles inflect like adjectives while avoiding the appearance of adjectival marking on tensed verbs.

I propose the following. The lexical matrices in (10) offer a partial account of the facts.

10) a [+]_[-N]____] _[-N], +TNS, αNUM, βPER, ...]
 [+V] [+V]

10) b $[+]_{[+V] \text{---}}]_{[+V], \alpha \text{NUM}, \beta \text{GEN}, \dots]}$

Assume that verbal stems occur in the lexicon as $[-N, +V]$. Adjectival stems appear as $[+N, +V]$. Given the subcategorization frames of the matrices in (10), (10)a will be able to affix only to verbal stems. (10)b, on the other hand, will affix to any stem specifying a $[+V]$ categorial feature. Since both verbs and adjectives contain $[+V]$, (10)b will occur as an affix appropriate to both classes of words. Hence, the inflection of verbal participles with affixes parallel to adjectives can be described.

The account offered here is sufficient to account for the morphological properties of adjectives, participles and tensed verbs. I will defer until the next chapter an account of their distribution in phrasemarkers.

Having given an account of verbal inflection, a similar explanation can be given for the morphology of regular nouns. For instance, the contrast in (11) can be explained assuming the lexical listings in (12).

11) a dog

b dogs

12) a $[\text{dog}, [+N, \dots], \dots]$

b $[\emptyset, [+N]_{N^0 \text{---}}]_{N^0, -\text{NUM}, \dots}, \dots]$

c $[\text{s}, [+N]_{N^0 \text{---}}]_{N^0, +\text{NUM}, \dots}, \dots]$

(13) exemplifies the derivation for (11)b.

13) a

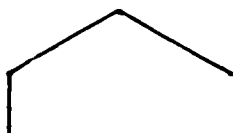

b

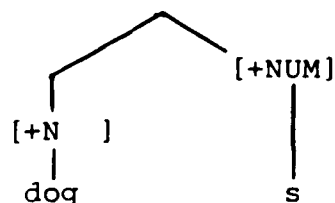

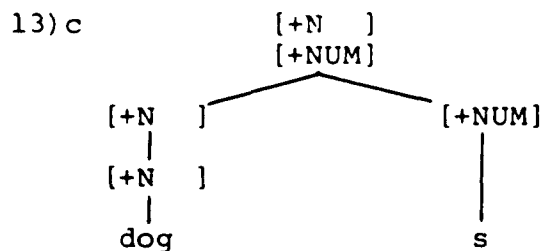

(13)a shows the application of the hierarchical rules; (13)b, insertion of lexical material and (16)c, percolation.

English does exhibit some irregular noun classes which require extensions and revisions of the theory proposed. The facts are given in (14), (15).

14)a The fish is smelly

b The fish are smelly

15)a *The scissors is sharp

b The scissors are sharp

In (14), the verb shows regular alternation for number marking, although the subject NP does not. In (15), there is a contrast in grammaticality although the alternation for number in subject noun and verb is completely regular. (15)a is ungrammatical due to the fact that there is no singularly inflected noun, "scissor" (or, for that matter, "scissors"). The examples in (14) are representative of a class of nouns having morphologically unmarked plurals; those in (15), of *pluralia tantum*.

The agreement properties of nouns like "fish" can be best explained if it is assumed, not that they are uninflected, but that the features representing inflection are sufficiently abstract to permit zero-allomorphs. Thus, along with the phonologically realized plural morpheme in (15)b,

there is the zero-allomorph in (16).

16) [\emptyset , [+]_{N°}___]_{N°}, +NUM, ...], ...]

Because there is no apparent syntactic regularity governing selection of the zero plural marker, the noun class taking the allomorph in (16) must be stipulated, member-by-member, in the lexicon.

To account for *pluralia tantum*, another kind of revision is required. First, it is necessary to consider the feature percolation conventions proposed in Lieber (1980) and recorded here as (17).

- 17)a Convention I: A stem morpheme (i.e., a morpheme lacking a subcategorization frame) labels the first nonbranching node dominating it.
- b Convention II: An affix node labels the first branching node dominating it.
- c Convention III: If a branching node fails to obtain features by Convention II, features from the next lower labeled node are automatically percolated up to the unlabeled branching node.

The problem is to rule out the word in (18)a while permitting (18)b, given the free application of lexical insertion.

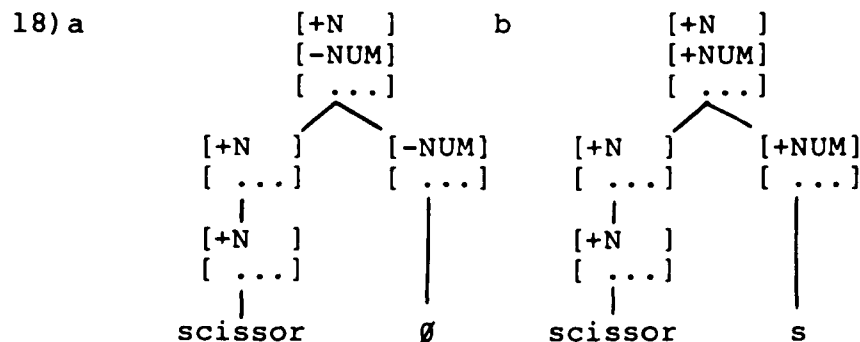

One might reasonably assume that (18)a can be ruled out by proposing the lexical listing in (19) for "scissor."

19) [scissor, [+N,+NUM,...], ...]

But Lieber interprets the conventions in (17) as permitting the form in (20).

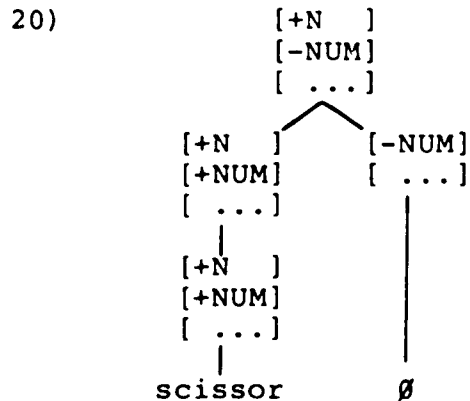

Lieber observes that

the entire feature content of a morpheme is percolated up a tree along with the category features of the morpheme. That is, derived words as a whole characteristically adopt all values of their outermost morphemes, and not only the category of outside morphemes (p. 84).

She states further that there is no *a priori* reason why some inner morpheme should not control the (inflectional) properties of a word, but that she knows of no such cases. The conventions in (17) are, hence, constructed to eliminate such a possibility. Observe, however, that the case of *pluralia tantum* can be explained if the inflectional number feature assigned to the stem in (19) is permitted to identify the inflectional properties of the noun, "scissors." In short, a [-NUM] affix cannot be assigned to a [+NUM] stem or vice versa.

Williams (1981) Righthand Head Rule (RHR) fares no better with these facts than Lieber's (1980) Percolation Conventions. The RHR is stated in (21).

21) The head of a morphologically complex word is the righthand member of that word

in (26) and (27).

- 26)a The sportscaster is annoying
*The sportscaster are annoying
b *The sportscasters is annoying
The sportscasters are annoying
- 27)a The cowboy is tough
*The cowboys is tough
b *The cowboys is tough
The cowboys are tough

The pattern of contrasts in (26), (27) shows that agreement of verbs with complex subject nouns is controlled by the righthand member of the complex nominal. If the inflectional as well as the categorial character of a word is determined by the word's head, then Williams' Righthand Head Rule makes the correct predictions in this range of cases.

Now let me reconsider the *pluralia tantum* cases in light of the RHR and my comments on its relation to inflection. The first question is whether simple nouns with inflection are morphologically complex. The second is whether *pluralia tantum* are. Williams (1981) suggests that any word is morphologically complex which undergoes one of the rules in (28) (his (1)).

- 28) $X \rightarrow X \widehat{af}$ or $X \rightarrow af \widehat{X}$

Given that he argues that inflectional and derivational morphology are not distinguished, I assume that (26) is the schema for both. It follows that inflected words are morphologically complex. Under the RHR, then, inflection may count as the head of a word. Given the formalization I

have adopted (cf., in particular, (2)), the consequences of counting the inflectional morpheme as head and permitting the head of a word to determine its categorial and inflectional features are borne out. An inflectional affix determines a word's inflectional properties via Percolation, its categorial character via subcategorization. However, as I have shown, Percolation and subcategorization do not account for the properties of *pluralia tantum* under the RHR if, in fact, such cases are morphologically complex.⁵

I assume, then, that *pluralia tantum* are morphologically simple (noncomplex) in a way to be described below. To the extent that my hypothesis is correct it confirms Lieber's view that stems must be inflectionally marked in the lexicon.

I propose to take advantage here of a slight deviation in my theory from Lieber's. Lieber assumes that inflectional affixes are generally of the form in (29).

29) [Δ , [+X,+]_{Y°}___]_{Y°},+Z,...], ...]

X represents a categorial feature (complex), Y°, the category of a stem which the affix subcategorizes and Z, an inflectional feature. In effect, (29) opens the possibility that an inflectional morpheme for a feature Z may subcategorize for a stem of category Y° where the word resulting will be of category X°, X° distinct from Y°. I believe it is a commonplace observation that inflectional affixes do not determine the categorial status of words to which they are affixed, at least not in the same sense as derivational affixes. On the other hand, observation of English shows

that the class of inflectional affixes for verbs is distinct from that for nouns. The latter fact can be adequately accounted for by the subcategorization feature in (29). Inflectional morphemes for verbs subcategorize verbal stems; inflectional morphemes for nouns, nominal stems. There is no need for any inflectional marker to carry with it a categorial feature so long as it may subcategorize the stem to which it is affixed. Since the elimination of the categorial feature, +X, from (29) reduces redundancy in the categorial specification of words, it is theoretically preferred so long as it correctly predicts the facts.

It follows that words bearing inflection receive their inflectional features under Convention II and their categorial features under Conventions I and II. If Percolation and immediate dominance are the only relations that obtain between X and the head of X, it is also true that inflected words are doubly headed in the sense that they have an inflectional head and a categorial head. Suppose, however, that morphologically simple words have a unique head. What I will show now is that *pluralia tantum* have a unique head, the form proposed in (30).

30) [Δ , [+N,+NUM,...], ...]

To begin, suppose that the morpheme determining the categorial status of a word may identify its inflectional properties. The proposal can be formalized as follows. Assume that [+N] actually represents a complex of features, viz., [α NUM, β PER, γ GEN] (among others, perhaps). Ordinarily, the values of said features are specified by regular processes

of inflection. However, they also have the opportunity of being inherently specified. In *pluralia tantum*, the number feature is inherently specified [+NUM]. When the Percolation Conventions apply to promote the categorial feature [+N], it follows that they actually promote a feature complex containing a number feature, specified or unspecified. In the case where the number feature is unspecified, the affixation of an inflectional affix suffices to provide the required feature. Now take the case of a number feature specified in [+N]. Consider the alternative on which an inflectional affix with distinct features is inserted in the word tree as shown in (31).

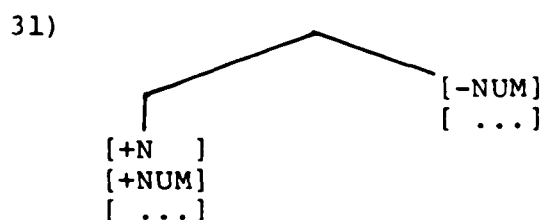

Two results are possible from Percolation, both given in (32).

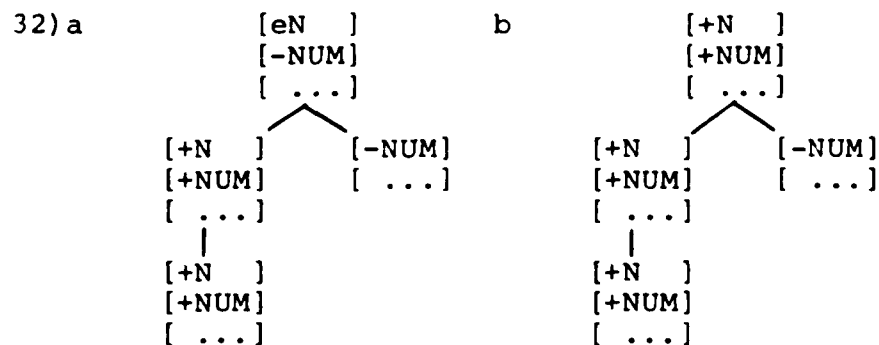

(32)a follows from the application of Conventions I and II. I assume that the presence of inflectional features is necessary for a well-formed noun, but not sufficient. That is, [+N] is a complex of features of which inflectional features are only a subset. Hence, (32)a is ruled out. If Convention III applies the result is (32)b. [+N] may not percolate inde-

pedently of [+NUM] to derive (33) because [+NUM] is part of [+N]'s identity.

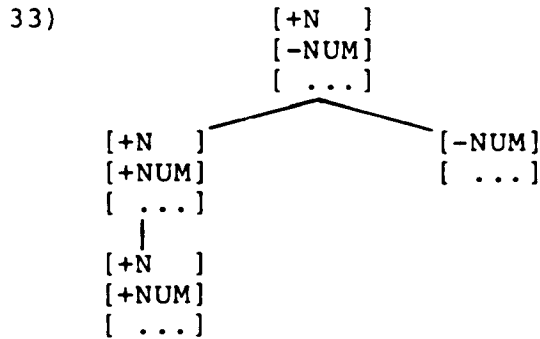

Further assume that Percolation is obligatory. Then (32)b is ruled out because [-NUM] and [+NUM] percolate onto a single node. But no node may be both [-NUM] and [+NUM] at the same time.

So far I have considered alternation for inflection in nouns to be a regular and productive process. However, the facts show that number inflection in English nominals is regular in only a subclass of nouns. Consider the facts in (34).

- 34)a mud, *muds
- b water, *waters
- c snow, *snows

Many grammarians cite the contrasts in (33) as evidence that mass nouns have no regular inflection for the plural. Presumably agreement facts like (35) show that mass nouns are marked for singular in English.

- 35) The mud is deep
- *The mud are deep

Hence, it appears that number inflection in nouns must be sensitive to the count/mass distinction.

It is possible to take advantage of the subcategorization frames associated with affixes to express the generalization about the distribution of number inflection in mass nouns. First, I assume nouns are divided into two lexical classes by the binary feature, [\pm C(OU)NT]. The lexical listing of the plural affix can be revised accordingly as in (36).

- 36) [s, [\pm]_{N^o} ____]_{N^o}, +NUM, ...], ...]
 [+CNT]

Given (36), pluralization will occur only in count nouns.

The generalization that mass nouns do not take plural inflection does not appear to be without its exceptions.

Consider first the pairs in (37), (38).

- 37)a The metal is heavy
 b The metals are heavy
38)a The oatmeal is on the table
 b The oatmeals are on the table

In (37)a and (38)a, the subject NP is assigned a mass denotation. By contrast the b members of the pairs in (37), (38) are assigned the interpretations in (39)a and b, respectively.

- 39)a Those kinds of metal are heavy
 b Those kinds of oatmeal are on the table
 Those portions of oatmeal are on the table

In the cases under observation, the affixation of the plural marker to a mass noun stem is not unacceptable. On the other hand, the pluralities denoted by (37)b and (38)b are not pluralities of individuals but pluralities of kinds or portions.

The contrast between unacceptably pluralized mass

nouns like "gold," "mud," "snow," etc., and acceptably pluralized nouns like "metal" and "oatmeal" can be explained if it is assumed that the latter have two lexical listings, e.g., like (40) for "metal."

40)a [metal, [+N,-CNT,...], ...]

b [metal, [+N,+CNT,...], ...]

(40)a is the ordinary mass noun. But since "metal" also has the lexical listing in (40)b, it has a stem form which meets all the subcategorizational requirements of (36). The former examples, however, lack a dual listing like (38); specifically they lack the form analogous to (40)b. Thus, affixation of the plural marker can go forward with the stem in (40)b in a completely regular fashion and the "metal," "oatmeal," etc., are predictably acceptable. But where there is no [+CNT] stem, the subcategorization feature in (36) is violated and the unacceptability of "muds," "snows," etc., results.⁶

There is a small residue of exceptional cases cited by Cartwright (1975) and others. Consider the facts in (41), (42).

41)a The bean is on your plate

b The beans are on your plate

42)a *The entrail is all over the floor

b The entrails are all over the floor

Unlike the previous examples (37), (38), the mass denotation of the nouns is not associated with the singular form in the a examples. In (41)a, the subject NP denotes an individual only; (42)a is simply unacceptable. The mass denotation is associated with the plurally marked stem. (41)b has, in

addition to the mass interpretation, the readings associated with an ordinary plural count noun.

I propose to treat the mass interpretations of (41)b and (40)b on the pattern of *pluralia tantum*. That is, the nouns in those examples will be listed as (43)a and b, respectively.

43)a [beans, [+N,-CNT,+NUM,...], ...]

b [entrails, [+N,-CNT,+NUM,...], ...]

"Beans" and "entrails" will differ in that "bean" has the additional lexical listing in (44).

44) [bean, [+N,+CNT,...], ...]

(44) will be available for the regular affixation of singular and plural markers and underly the individuating denotations of that word.

I have left one generalization unaccounted for. When a mass noun like "mud," "snow," "metal," "oatmeal," etc., are pluralized, the NP's of which they are constituents denote kinds or portions.

It is a commonplace observation that count nouns may be used to refer to individuals or kinds. For example, count nouns regularly occur in generic contexts like (45).

45) The crow is a black bird

Men are rational bipeds

The subject NP's in (45) refer not to individuals but to classes of individuals or kinds. Cartwright (1975) argues that some of the distributional similarities of singular mass nouns and plural counts might originate in a lack of distinction between the stuff denoted by "some water" or "some gold"

and the classes denoted by plurals of, say, man or lion. Carlson (1977) extends the line of reasoning to argue that bare plurals like the subject NP in "Dogs are running down the street" are singular terms denoting kinds. However, the observations of Cartwright and Carlson offer only the beginning of an account of the facts I observe.

It must be noted that the denotations of the subject NP's in (37)b, (38)b are more restricted than those of regular count nouns. That is, "the metals" and "the oatmeals" never denote pluralities of individuals as the plurally marked count noun may. The subjects in those cases denote only kinds or portions. I can only speculate as to the source of the restriction.

Suppose that the only respect in which (40)a and b differ is in the representations of their syntactic matrices. More specifically, the semantic representation of (40)a and b is identical. The hypothesis is consistent with Katz's (1972) argument that [α CNT] is a feature determining the syntactic distribution of nouns with their determiners rather than semantic interpretation. Further suppose that the lexically listed plural marker has semantic properties which permit it to individuate the extensions assigned to the noun stems to which it is affixed. Count nouns (in an informal sense of "count" here) express predicates which permit individuation of their extensions into individuals and kinds. Mass nouns (again, in an informal sense) possess semantic representations sufficient only to the individuation of kinds or portions in the presence of individuating apparatus contained in number

markers or specifiers. Consider in this light (46).

46)a *A gold was smelted here

b *Golds were smelted here

While both examples in (44) are unacceptable,⁷ intuitively they may be assigned the paraphrases in (47)a and b, respectively.

47)a That kind of gold was smelted here

b Those kinds of gold were smelted here

By hypothesis, "gold" has only a [-CNT] lexical representation. The supposition is sufficient to account for the unacceptability of both examples in (46). I will discuss the mechanics of the account for (46)a in the next chapter. Since "Gold was smelted here" does not mean "A kind of gold was smelted here" it is plausible to assume that the semantic representation associated with the lexical listing of "gold" contains only the semantic representation associated with mass readings. The observations are predicted if my hypothesis concerning the individuating properties of the plural marker and the interaction of those properties with the semantic representation of mass nouns is correct.

In conclusion, I would like to reiterate some of the results obtained in this chapter. In my observations of nonnominal inflection, the distribution of number affixes appears to depend only on other inflectional properties of the constituent involved. A case in point is verbal inflection. Number is spelled out only in [+TNS] contexts. By way of contrast, the distribution of number marking in nominals is marked by interactions between inflectional

features and other syntactic, noninflectional features of noun stems like [α CNT]. Also, number marking appears to interact with the semantic reflexes of the syntactic count feature in a way that determines interpretation. Such is not true of the interaction between number inflection and tense. Furthermore, no verbs are represented in the lexicon with an inflectional feature in their syntactic matrices. Some nouns are. I believe that the evidence points to the truth of Jespersen's observation that number features are inherently nominal and appear in other categories only as reflexes of agreement.

Footnotes

1. Chomsky (1981) and others argue that Affix-Hopping is simply the reflex of Move α in derivations from S-structure to PF in the same way May's (1977) Quantifier Rule is the reflex of Move α in derivations to LF. Deciding between the alternatives is beyond the scope of my dissertation which ultimately selects a hypothesis on which Affix-Hopping is not required.
 2. Cf. Chap. I, fn. 4.
 3. I assume "... " to contain appropriate features for person, gender, and tense.
 4. Cf. Hyams (1980) for arguments to the contrary based on the affixing properties of adjectives in Italian.
 5. Lieber (1980) rejects the Righthand Head Rule in favor of a fourth Percolation Convention given in (i).
 - i) Convention IV: In compound words in English features from the righthand stem are percolated up to the branching node dominating the stems
- She argues that while the RHR is universal and predicts that no feature ever percolates up from a lefthand constituent, there are language-specific cases of percolation from the left. Cf. Lieber (1980), pp. 92-102 for further discussion.
6. Fiengo (p.c.) suggests that most if not all nouns have a count and mass lexical listing. The observation is similar to that argued for in Pelletier (1979).
 7. Intuitions vary widely on these cases. Fiengo (p.c.), for example, notes that for him cases with "gold" are perfectly acceptable with the readings given.

Chapter III
Number and Agreement

The present chapter investigates the description of agreement pairs. I define "agreement pairs" tentatively as (1).

- 1) For any pair of constituents (δ, ϵ) such that δ, ϵ occur in $\sigma (\dots [\sigma \dots \delta \dots \epsilon \dots] \dots)$, (δ, ϵ) is an *agreement pair* iff:

i) δ is [+N, -V]

and ii) ϵ is inflectionally identical to δ

By "inflectionally identical" I mean that δ and ϵ contain the feature matrix, $[\alpha\text{NUM}, \beta\text{PER}, \gamma\text{GEN}]$, and the specification of the featural coefficients of the matrix are exactly the same for δ and ϵ . I will, of course, be concentrating almost exclusively on $[\alpha\text{NUM}]$. Examples will show that the order of δ and ϵ is not crucial; ϵ may precede δ if appropriate conditions are met. (1) captures two conditions on agreement relations observed in Moravcsik (1978). She concludes that all agreeing constituents "refer back" to some nominal, clause (i), and the inflectional identity clause, (ii), captures her description of the "meaning-related properties" on which agreement is based. The values of σ are intentionally unidentified. Intuitively, the variable corresponds to the domain in which agreement relations occur. Most of the remainder of this dissertation is devoted to the investigation of values for σ . In this chapter I will argue that the notion of case domain plays an important role in determining those values.

I will begin by examining the interaction of agreement and other syntactic processes, specifically tense placement in finite clauses. There are two theories I want to discuss. The essential distinction is represented by the (approximate) phrasestructure rules in (2).¹

2)a S → NP INFL VP

b S → NP VP

(2)a is the classic S-expansion rule (neglecting for the moment bar-structure). Part of the justification of (2)a is the account it yields for the distribution of tensed verbal forms in English. INFL is affixed to an adjacent verb in VP by Affix-Hopping, a transformation with morphological reflexes. Affix-Hopping is independently justified by the account it offers for the distribution of progressive and perfective aspects in English. More recent research (e.g., Chomsky (1981), Stowell (to appear)) have provided additional arguments for (2)a. (2)b represents a proposal for an "INFL-less" base found in Fiengo and Battistella (1980) and Battistella (1980). Its major claim is the achievement of a unified morphology for inflection under conventions for percolation and rules of affixation. Before moving on to the latter theory, I would like to examine for a moment the theory of an inflection-headed S.

Two options are here available. On one, the base rule for expanding INFL into a complex symbol will be (5)a.

3)a INFL → [\pm TENSE]; [+TENSE] → [α PRO]

b INFL → [\pm TENSE]

()b is consistent with my own theory of the base generation

of [α NUM].^{2,3}

The alternatives exhibited permit the construction of the phrasemarkers in (4)a and b, respectively.⁴

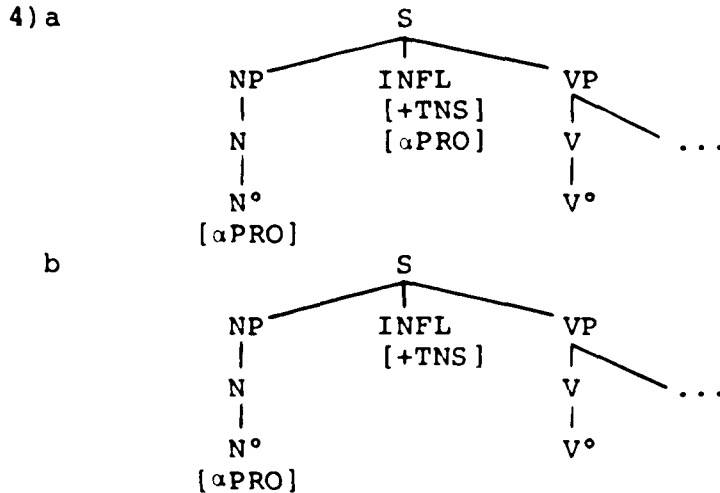

Given the rules in (3)a, the base also generates the form in (5), parallel to (4)a in every respect except one.

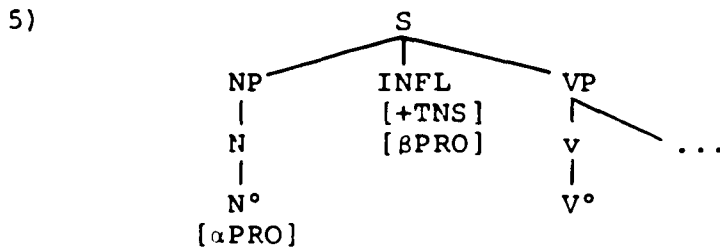

Assuming that $\alpha \neq \beta$, (5) will underly such unacceptable examples as "The rock are heavy" and must be ruled out by the Agreement Filter. On the other hand, (4)b offers an alternative on which the application of some copy rule like the Agreement Transformation of Chapter I must be forced. If the expansion of the base rules is fully free, (4)b as well as (4)a will be generated by the rules in (3)a. The Agreement Filter will, accordingly, have to be stated on conditions of strict syntactic identity rather than nondistinctness. Both theories will require some morphological rule

similar to Affix-Hopping, perhaps Fiengo's (1980) Hop C, to embed INFL in the verbal structure where it is phonologically realized. It is not obvious whether the rule leaves a trace of the usual sort. At least in government theory, the trace of INFL need not be properly governed as other empty categories, in particular, trace, must be.⁵ Safir (to appear) argues extensively for the Head Uniqueness Principle in (6).

6) \bar{S} must have a unique governed head.

(6) forces INFL to move into a position in which it can be governed while requiring that the trace of INFL be ungoverned; the phonologically realized INFL must be the only governed head of \bar{S} . Fiengo (1980) suggests that traces of Hop C are subject to exactly the same left-side constraints as any trace, viz., the Priority Filter which in his theoretical framework subsumes superiority and subjacency violations. I leave these questions open here.

From my brief description of a base component containing an inflectionally-headed S, I think it is clear that no choice between alternatives is possible on the grounds of restrictiveness with respect to principles so far developed. Either is equally costly in terms of mechanisms required for description. It follows that any choice will be empirical short of the postulation and investigation of further meta-theoretical constraints which might turn out to be expressed in a less costly fashion in one theory rather than the other. But the prior question of a rationale for any theory of an inflectionally headed S is the one I want to address at the moment.⁶

From the point of view of Government Theory, I see two related reasons for adopting the theory of an inflectionally headed S, the properties of nominative [+NOM] case assignment and the explanation of the PRO-Drop parameter. Under the theory of case assignment ordinarily associated with Government Theory, subjects cannot obtain case by subcategorization. It follows that nominative case must be assigned by structural configuration, e.g., following (7), or INFL must be included among the set of possible governors and case assigners.

7) Assign [+NOM] to any NP in the configuration [NP,S]
The adoption of (7) leads to immediate problems with examples like (8).

8)a John expected him to leave

b *John tried he to leave

(cf. John tried to leave)

(7) predicts the acceptability of (8)b and the unacceptability of (8)a. Other problems are occasioned by subject inversion processes in Romance languages where [+NOM] is assigned to NP's which are not daughters of S.⁷ Given the obvious relation between the assignment of [+NOM] and the presence of [+TNS], the usual technique is to assume that INFL is a constituent in the class of governors. It then follows that, given INFL's government relation to subject NP, [+TNS] may assign [+NOM] to [NP,S] under the usual assumptions about case assignment via government. The absence of INFL in the base as an immediate constituent of S precludes any such solution of nominative case assignment. No inflectional element embedded under VP

is in a position to govern subject NP's given the definition of government in (9) (from Chomsky (1981)).

9) α governs β in a structure, $[\gamma \dots \beta \dots \alpha \dots \beta \dots]$,

iff:

i) $\alpha = X^\circ$

and ii) if ϕ is a maximal projection, ϕ dominates

α iff ϕ dominates β

I will follow Safir (to appear) in defining "maximal projection" by (10)b although, for my purposes, no empirical consequences will follow from the distinction made between maximal and base-maximal projection.⁸

10)a X^n is the *base-maximal projection* of X° if n is the highest value for the category X in the base

b A *maximal projection* of X is the highest projection of X° , X^n , where X^n is base-maximal.

It follows from (9) that VP is a barrier to government. Thus, INFL embedded in VP cannot govern a subject NP. So with respect to maintaining a reasonably uniform and empirically adequate theory of case assignment in Government Theory, it is necessary to hypothesize an inflectionally headed S.

If Chomsky's (fall lectures, 1980) recent analysis of phenomena surrounding the residue of the Nominative Island Constraint (RESNIC) is in the vicinity of truth, then another argument for the constituent INFL can be constructed. Briefly, the line of reasoning follows.

Rizzi's (ms.) research, followed by Jaeggli (1980) and others, suggests that $[_{NP} e]$ (where $[_{NP} e]$ represents the trace of movement but not PRO) is not permitted in subject

position of tensed S's of any language regardless of whether that language permits PRO-Drop (phonologically null subjects) or not. He presents evidence that Quantifier Raising (QR) appears not to operate out of subject position in French or Italian. The lack of contrast is not predicted by any theory which permits AGR (the INFL realization of PRO) to be a proper governor in the sense of (11) in order to explain why some languages have empty subject positions in tensed S's.

11) α properly governs β iff:

i) α governs β

and ii) a α is lexical ($N^\circ, V^\circ, A^\circ$)

b α is coindexed with β

INFL is a proper governor by virtue of being coindexed to its agreement source, [NP,S]. In PRO-Drop languages, it would follow that agreement coindexing is sufficient to properly govern subjects permitting [NP e] to appear in that position. But if AGR is a proper governor, it follows that QR ought not to violate the Empty Category Principle (12) in such languages.

12) [NP e] must be properly governed

The result is contrary to the evidence, if it is assumed that the scope phenomena examined by Rizzi and Jaeggli are a reflex of (12). That is, only narrow scope readings are permitted in embedded clauses of tensed S's because "long" movement by QR for wide scope readings would violate (12). Hence, AGR cannot be a proper governor.

Chomsky suggests that the ECP be revised to (13).

13) [NP e] must be lexically governed

While INFL may serve as a governor, it is not a lexical category (X^0). Although AGR must be coindexed with its agreement source, it cannot serve as a proper governor in the sense required by the revised ECP. It follows that trace may never appear in subject position. But since some subjects are null as in (14), some phonologically null NP must be in subject position given that there is no source of bare VP.⁹

14) Lo mangia

"He/she ate it"

The only option is PRO. But an essential property of PRO is that it must be ungoverned.¹⁰ However, the initial assumptions about nominative case assignment for sentences containing phonologically realized subject NP's require INFL to be a governor. The problem is resolved by assuming that the rule affixing INFL to V may be either syntactic or morphological. To generate subjectless NP's, it is assumed that INFL is embedded in V in derivations to S-structure. It follows that subjects can be ungoverned at S-structure, apparently because trace of INFL is nonexistent or cannot govern. Where the embedding of INFL is morphological, subject position is governed at S-structure and hence cannot be PRO. The difference between null subject and nonnull subject languages is expressed as a constraint on the movement of inflection. Nonnull subject languages like English have only a morphological rule of INFL embedding. Languages like Italian permit both syntactic and morphological applications of INFL embedding. Observe that it is crucial to this solution of the PRO-Drop parameter that INFL be, at some level of the

grammar, an independent constituent. Hence, insofar as the account of empty subjects in tensed sentences is correct, there is evidence that INFL must be generated in the base as the head of S.

If the assertion of the locality governing agreement expressed in (15) is correct, a third argument for an inflectionally headed S can be constructed.

- 15) Every agreement pair (δ, ϵ) is such that δ governs ϵ
or ϵ governs δ

Under the theory of the INFL-less base, the phrasemarker underlying (16)a is (16)b.

16)a He walks

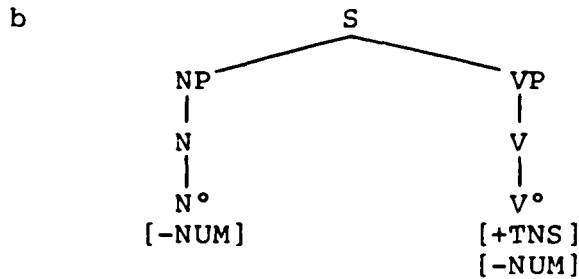

The agreement target does not govern the agreement source in (16)b. Hence, (N°, V°) is not a possible agreement pair. The theory would predict that subject/verb agreement is marked. Otherwise, some other theory of the base must be proposed. An inflectionally headed S fits the bill. Agreement must apply prior to Affix Hopping, but consistent with (1), INFL does occur at some point in the derivation as a constituent governing its agreement source.

Given the distribution of agreement pairs in terms of categories, (15) is reasonably accurate, predicting that INFL agrees with subject NP's; verbs and prepositions with

their objects. If it is assumed that agreement pairs are indifferent with respect to whether the agreement target is the governor or governee, then nominal/specifier and nominal/adjectival pairs can be added to the list. More surprising, the agreement-like properties of partitives like "a pile of" and "a group of" can be explained. The exceptionally nouny character of partitive specifiers in English permits them to govern N° as their complements, the *of*-phrases. If agreement pairs are not so indifferent then the difference between NP-internal and NP-external agreement observed in Moravcsik (1978) can be traced to a predicted asymmetry. In NP-internal examples, agreement sources are governors. Furthermore, it is predicted that subject/participle, subject/predicate adjective and subject/predicate nominal agreement pairs are marked instances of agreement. The same goes for agreement of anaphoric pronouns with their antecedents, unless, of course, the agreement of anaphor pairs is simply a property of such relations irrespective of agreement domains. Also, the distribution of quantifiers in Quantifier Floating structures either has a source where the floated quantifier is in a government relation to its agreement source or similar remarks obtain as were made in the case of anaphoric agreement. Finally, because agreement in such a theory is dependent upon configurational properties of the syntax, it is possible that the agreement properties of nonconfigurational languages such as Warlpiri are not at all like those I have been investigating.

Putting aside Government Theory, I turn to the problem of describing the distribution of agreement pairs in an INFL-

less base. Fiengo and Battistella (1980) and Battistella (1981) investigate the properties of a theory of case assignment embedded in a linguistic theory containing no inflection node. The immediate implication of such a theory is that case assigning relations are not (necessarily) a subset of government relations. Given the close association of case and number inflection, it is perhaps possible using the notion of case evolved in Fiengo and Battistella's Case Dropping framework to describe a locality principle for agreement independent of government.

A reasonable point to begin discussion of the INFL-less base is the interaction of the phrasestructure rules and lexical insertion. In Chapters I and II, I stated that the framework which I was elaborating is compatible with an abstract phrasestructure component of the form in (17).

$$17) \quad x^n \rightarrow \dots x^{n-1} \dots$$

Given the constraints associated with (17), there will be generated forms like (18).

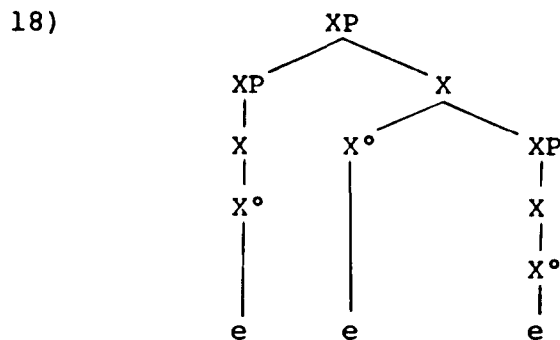

"e" represents the identity element and reserves positions in the terminal string for the insertion of lexical items. Stowell (to appear) argues that, given (18) and assuming that INFL is head of S, it follows that the notion of

subject of S generalizes across categories and the uniformity of categories predicted by the base rule in (17) is maximized. For English, lexical insertion will specify the structure in (18) as (19).

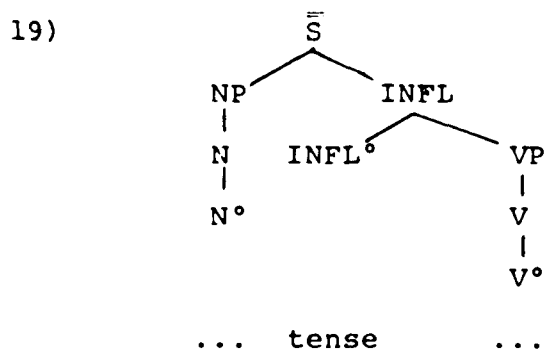

I assume that the insertion of tense also carries with it agreement and categorial features, the identity of which will be discussed below. In (19), INFL serves as the head of S. In essence, X-bar assumptions are preserved in terms of a specific cost, the marking of verbal inflection for tense and agreement by a transformation operating on inflectional features.

Adopting an abstract phrasestructure component to the theory of an INFL-less base requires the generation of hierarchical structures as in (20).

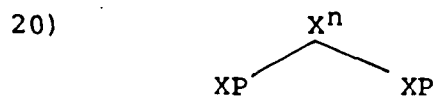

(20) is the structure abstracted from (21).

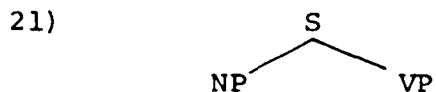

On this account, the node S violates X-bar constraints as a "headless" or exocentric category. Furthermore, it is unclear how S would derive its featural content via Percolation as

from some lexical category if the rule is defined, following Safir (to appear), as in (22).

- 22) If X^n is a maximal projection of X , and X^n has the feature, $[\alpha F]$, then for all SPEC of X^n and X^m , $m < n$, X^m and SPEC of X^n are also $[\alpha F]$

Because S in (21) is the maximal projection of no lexical category, it cannot be featurally specified under the rule in (22). Presumably, a categorially marked phrasestructure rule is required. But a trade-off is achieved; there is no need to propose the marking of morphological reflexes via transformational rules.

Williams (1981) proposes a base rule similar to that which would generate (21). He speculates that an appropriate syntactic definition of head would permit tense to be a head feature of S even when generated in VP . Another problem remains, the specification of the categorial features of S . Of course, there is no problem if S is merely a projection of VP as argued by Jackendoff (1977), Marantz (1979) and others. However, I believe a better account of the properties of S is derived from the assumption that it is categorially specified as $[-N, -V]$. For example, if S is $[-N]$, then the extraposition phenomena analyzed by Stowell (1981) follow from his Case Resistance Principle in (23).

- 23) Case may not be assigned to a category bearing a case assigning feature

Under standard assumptions, $[-N]$ is considered a case assigning feature. Then, following Kayne (MIT lecture), it might be supposed that $[-V]$ gives the distribution of possible

arguments. Observe that the phrasal constituents which appear in argument positions are NP, PP and S. NP and PP are assumed to be [-V] for independent reasons of distribution. Here, the generalization that NP, PP and S occur in argument position is syntactically encoded by specifying all of them as [-V]. Finally, as will be seen in detail below, if Fiengo and Battistella (1980) are correct in assuming that case assignment principles are restricted to inherent specification and subcategorization, then S must be [-N,-V]. While [-N] can be projected from VP, [-V] cannot. Similarly, [-N] cannot be projected from NP. Hence, it follows trivially that S is not a projection of VP and more generally that it is not a projection of either of the lexical categories explicitly exhibited in (21).

Now consider in more detail the internal structure of the categorial symbols, XP, X, X°. Under the theory I am assuming, categorial nodes have no existence independent of the features which compose them. The theory implies the structures made explicit in (24).

$$24) a \quad XP = [eN, eV]^2$$

$$b \quad X = [eN, eV]^1$$

$$c \quad X^\circ = [eN, eV]^0$$

In Chapter II, I argued that [α NUM] is an element of the featural identity of [+N]. Agreement facts show that number is also distributed in every other category. To reflect these facts, I propose that the general form of complex symbols include an inflectional matrix as in (25).

$$25) \quad [eN, eV, eNUM, ePER, eGEN, \dots]^n$$

The featural coefficients of complex symbols will be specified by lexical insertion and percolation.

My proposal leaves open the problem of S. I see two methods for solution. The first is to permit the specification of S via the insertion of features into SPEC of S, otherwise known as COMP. On this hypothesis, complementizers will have the general form in (26).

26) [Δ , [+COMP, -N, -V, ...], ...]

" Δ " will represent any of the allomorphs of complementizers including "that," "for," and a phonologically null element, the distribution of which is extensively discussed in Fiengo (1980). The second solution is to permit a redundancy rule of the form in (27).

27) [eF] \rightarrow [-F]

In effect, (27) says that any syntactic feature need be specified for a positive coefficient. From the paradigm of number agreement, there is some evidence for the proposal. Consider the sentences in (28).

28)a That the boy is sick is obvious

b That the boys are sick is obvious

When the "subject" of a sentence is a tensed clause, verbal agreement is singular in the matrix clause regardless of the number and agreement marking in the embedded clause. Suppose, in fact, that S's in general are not a possible source of inflectional features for agreement. Then the matrix verbs in (28) will not be specified for number inflection by agreement. However, the rule in (27) provides the appropriate feature specification. Other evidence is observed in

Battistella (1981). He notes that some sentences of Czech are tensed but regularly permit genitive subjects. Such constructions contrast with tensed sentences containing nominative subjects. The latter show subject/verb agreement for number; the former are always verbally marked for the first person singular regardless of the subject's inflection. Assuming that only nominative subjects are agreement sources, once again the rule in (27) comes into play to specify otherwise unspecified features. Deciding between the two proposals is beyond the scope of my discussion and I simply conclude that the featural specification of S will not be entirely symmetrical with respect to the specification of other lexical categories.

To exemplify the propagation of a typical phrasemaker, consider the example in (29).

29) The boys have been running

The PS rules in (30) will generate (31).

30)a $S \rightarrow XP \ XP$

b $XP \rightarrow \dots X \dots; X \rightarrow \dots X^\circ \dots$

31)

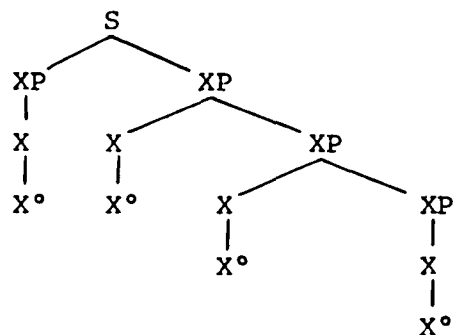

Given the description of the lexicon in Chapter II, we have at least the lexical items in (32).

- 32) a [N° [N° boy] [AFF s]]
 [+NUM] [+NUM]
- b [V° have]¹¹
 [+TNS]
 [+NUM]
- c [V° be]
- d [V° run]

The symbol "AFF" is assumed to be identical to the features explicitly listed; N° and V° have their usual content plus the listed feature(s). The partial lexicon in (32) must be developed further to account for the perfective and progressive forms of "be" and "run." Following Fiengo and Battistella, I will assume a class of verbal affixes based on the feature, [±PERFECTIVE] ([±PRF]). The addition to the lexicon of the representations in (33) will serve.

- 33) a [en, [+V°___]V°, +PRF, ...], ...]
- b [ing, [+V°___]V°, -PRF, ...], ...]

Given the morphological theory laid out in Chapter II, (33)a and b will be lexically affixed to (32)c and d respectively to yield "been" and "running."

Lexical insertion and percolation over the domain in (31) will result in (34).

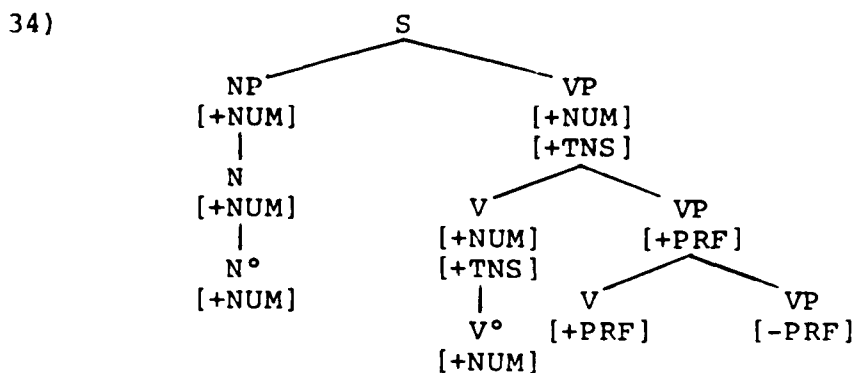

34)

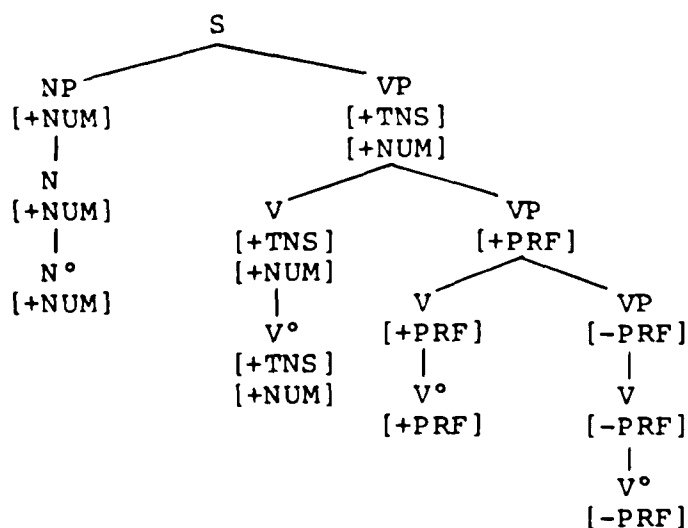

The boys have been running

The structure in (34) adequately describes the phrase-marker underlying (29) except for nominative casemarking. It also fails to give an account of the ordering of verbal sequences in English.

The occurrence of "have" and "be" as auxiliaries and the order of their string occurrences can be explained (partially) by the subcategorization rules in (35).

- 35)a VP → [+PRF]/ have ____
- b VP → [-PRF]/ be ____
- c VP → [+AUX]/ ____ VP

(35)c will identify any V node to the left of another verb as dominating an auxiliary. (35)a requires a VP to the right of "have" to be inflected for the perfective aspect; (35)b identifies a VP to the right of "be" as inflected for progressive aspect. In effect, auxiliaries subcategorize the inflectional features of other members of the verbal complexes in which they are contained. Fiengo and Battistella give a more detailed account of the rules in (35) and their

effects but the subject is orthogonal to my own hypothesis and I want to press onto the more central topic of case assignment.

Fiengo and Battistella argue that the theory of English inflection can be unified under the theory of case. To this end, they extend the Case Filter originally suggested in Vergnaud (1978) to (36).

- 36) Every node in a phrasemarker must have one and only one case feature

Observe that the structure in (34) fails to meet the condition in (36). Fiengo and Battistella's solution is to identify (at least some) inflectional features as reflexes of case assignment. In short, [\pm NOM(INACTIVE)], [+TNS], and [\pm PRF] represent reflexes of the assignment of case to constituents. Assuming that [+TNS] is identified with [+NOM], the marking of the subject and the tensed verb is accounted for. The perfective feature opposition represents marking for [-NOM]. However, the actual process of assignment remains unspecified.

Fiengo and Battistella hypothesize that case is inherent in [-N,-V] categories and elsewhere assigned by either Case Dropping, a process which I will formalize below, or subcategorization. Among [-N,-V] categories are S, PP and SPEC. Hence, I assume that among the features designating the category S is [+NOM]. Moreover, [-N,+V] categories may subcategorize their complements for [-NOM]. Thus, the rules in (35)a and b fall under the more general rule in (37).

- 37) VP \rightarrow [-NOM]/V ____

The system sketched generates trees of the form in (38).

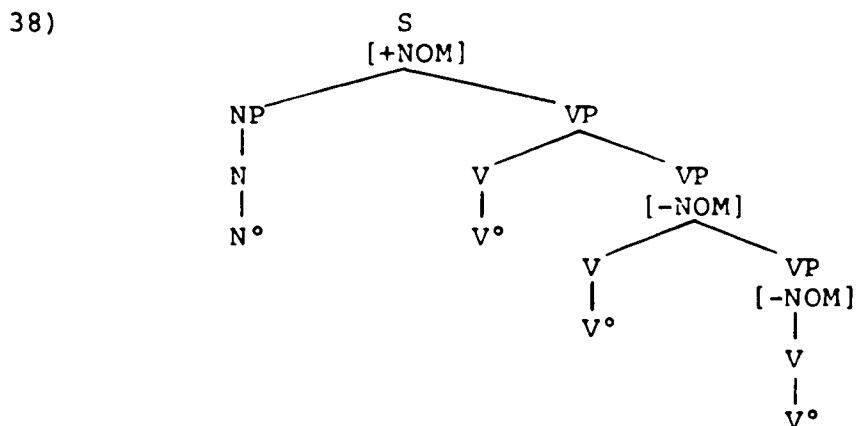

I ignore for the moment inflectional features propagated in the lexicon and percolated through the structure in (38). Fiengo and Battistella propose the rule in (39) to assign case to all the nodes in (38).

- 39) Given two nodes, A and B, where A immediately dominates B, assign the case specification of A to B

Application of (39) to (38) generates (40).

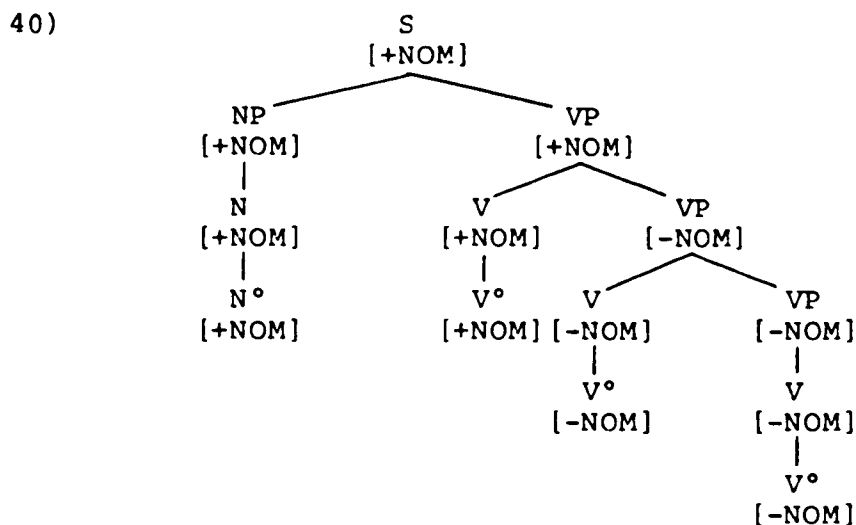

In the theory I am proposing there are two sources of case, categorial and lexical. That is, nodes may acquire

case by Dropping from some phrasal category or Percolation from some lexical category.¹² It follows that the conditions on the interaction of Dropping and Percolation will be crucial in ruling out cases like (41).

41) Them have been running

If Percolation and Dropping are optional, it is possible to generate an underlying structure, exhibited in (42), for (41).

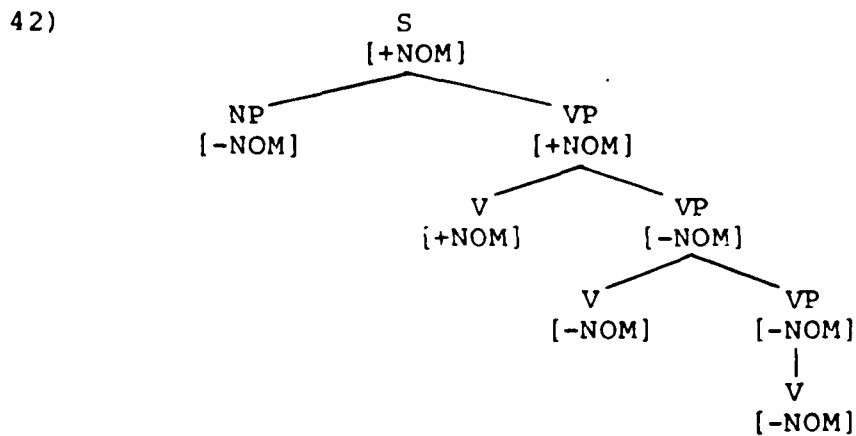

(42) is only one example of many possible misgenerations. Observe that nothing so far rules out (42); in particular, the structure passes the Case Filter (36). On the other hand, if Dropping and Percolation are obligatory, (43) will be generated as the underlying structure of (41).

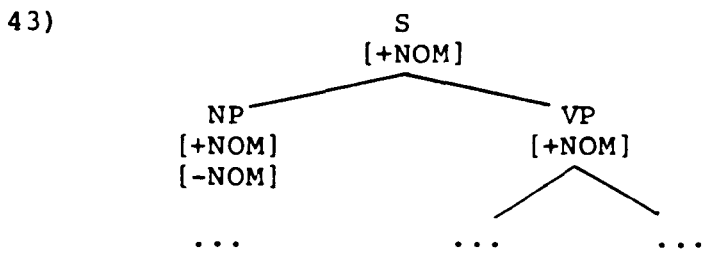

The NP node in (43) and any of the nodes it dominates violates (36); it contains more than one case feature. I will assume, accordingly, that Dropping and Percolation are obligatory so that (41) can be predicted by the Case Filter.

I have now outlined the theory of case assignment which will prove significant to my theory of agreement pairs. I turn to an explication of the latter immediately below.

Recall that the theory of agreement pairs that I offered at the outset of this chapter requires such pairs to be inflectionally identical. I propose that the rule of Percolation be extended to account for the property of inflectional identity in agreement pairs. To further my investigation of the proposal, it is necessary to change the definition of Percolation offered in (22).

Consider the rule Percolate α . Percolate α is an instantiation of a copying operation under the constraints in (44).

44)a Values of α are syntactic features

b Given two nodes, A,B, and a feature, [γ F], inscribed on A, [γ F] copies onto B iff A immediately dominates B or B immediately dominates A

(44) permits the Percolation of inflectional features out of the phrasal categories they head whereas (22) was implicitly interpreted as applying only as high as a maximal projection. Further observe that, on my formulation of Percolation, Dropping is a special case where A immediately dominates B.

Obviously the application of (44) to a phrasemarker overgenerates with respect to the distribution of inflectional features like [α NUM]. Consider again the structure underly "The boys have been running." Abstracting away from other inflectional features, Percolate α as formulated in (44) will derive (45)b from (45)a.

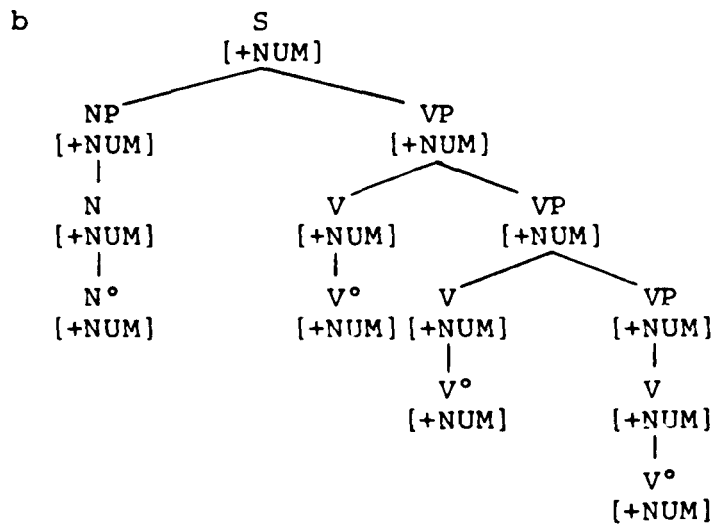
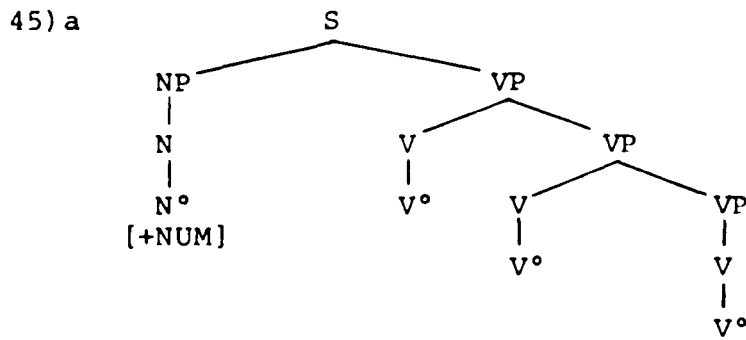

Intuitively, however, neither "been" nor "running" agree with subjects as (46) shows (for many "standard" dialects of English).

- 46) a *He been running
 *They been running
 b *He running
 *They running

It follows that (45)b ought to be ruled out by some principle of grammar.

I believe that a locality principle defined on case domains will supply the required strictures on (44). I define the notion of case domain in (47).

- 47) A *case domain* is the set of all nodes, C_1, \dots, C_n ,

such that some C_i , $1 \leq i \leq n$, contains inherent or subcategorized case and every other node, C_j , $i \neq j$, $1 \leq j \leq n$, is assigned case by C_i

Percolate α can be constrained by the locality principle in (48).

- 48) Two nodes, A and B, may receive a feature, $[\gamma F]$, from a node N iff A and B are in the same case domain.

To be explicit about the application of (48), reconsider the status of (45)b shown in (49) with the appropriate case features.

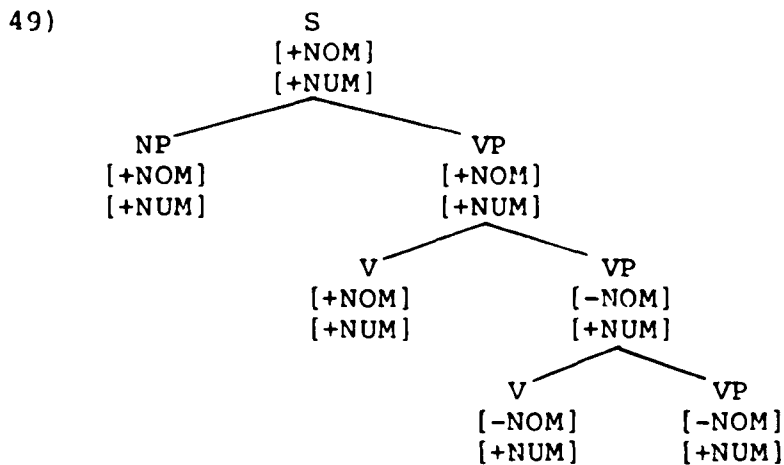

For purposes of exposition, I will call C_i in (47) a case assigning node. I will say that two nodes, A and B, are in the same case domain iff A is a case assigning node which assigns case to B or A and B are both assigned case by the same case assigning node. If two nodes are not in the same case domain, then they are in distinct case domains. In the case of (49), the crucial pair of nodes is the maximal VP and the VP it immediately dominates. The maximal VP is assigned case by Dropping from S. The dominated VP is assigned

case by subcategorization. It follows that the two VP's are not assigned case by the same case assigning node. Nor is one VP the case assigning node of the other. Since the nodes are not in the same case domain, they are, by definition, in distinct case domains. But (48) enjoins the inscription by Percolation of [+NUM] from the maximal VP onto the VP it immediately dominates if they are not in the same case domain. Hence, (49) cannot be generated although (50) can be.

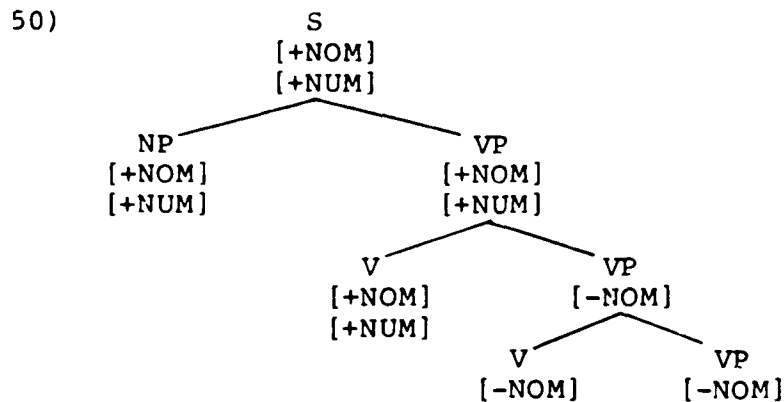

(50) is, of course, the intuitively desirable result for a phrasemarker underlying "The boys have been running."

Given the results above I conclude that the rule Percolate α formalized as (44) and constrained by the locality condition in (48) is, in fact, the rule of agreement.

The locality principle in (48) suggest a way to define values of σ in the definition of agreement pairs in (1). Suppose σ is a syntactic category. Then the notion of case domain given in (47) must be derived from the value of σ . Suppose σ is C_i in (47), that is, a case assigner. By application of Dropping, σ will assign case to every node it dominates assuming that it dominates no other case assigner, C_i' . If σ dominates some C_i' , then, by Dropping, σ assigns case to

every node it dominates except C_1' and the nodes dominated by C_1' . Given these observations, the notion of case domain can be structurally defined as in (51).

51) Given the structure, ... [σ ... ϵ ...] ..., ϵ is in the *case domain* of σ iff:

- i) σ is a case assigner
- and ii) there is no σ' such that σ' is a case assigner and σ' dominates ϵ but not σ

Two nodes will be in the same case domain if (52) holds.

52) Given the structure, [σ ... δ ... ϵ ...], δ, ϵ are in the same case domain iff:

- i) σ is a case assigner
- and ii) there is no σ' such that σ' is a case assigner and σ' dominates δ or ϵ but not both

Two nodes may be related by Percolation iff they meet the condition set in (52). If Percolation is the rule of agreement, then agreement pairs must meet the condition and σ in (1) will be determined to be any category which is [-N,-V] or assigned case by subcategorization.

To investigate further the properties of agreement pairs, I would like to examine the application of the hypotheses so far advanced to other instances of agreement in verbal constituents. For example, consider facts typical of Romance languages. Like English, French and Italian exhibit auxiliary plus main verb constructions. They follow the pattern of English in that a tensed verb must agree with its subject. However, they differ from English as well. While no

participle in English agrees with any nominal constituent, participles in French and Italian may, under predictable circumstances, agree with subjects and, in some cases, direct objects. The question is whether subject/participle and object/participle pairs fall under the definition of agreement pairs I have elaborated.

I will begin by analyzing the core facts of subject/participle agreement. Consider the examples in (53), (54).

- 53)a Il/elle est venu/venue
*Il/elle est venu/venue
b *Ils/elles sont venu/venue
Ils/elles sont venus/venues
- 54)a Il/elle a fini
*Il/elle a finis
b Ils/elles ont fini
*Ils/elles ont finis

I confine my discourse to French but I believe the analysis will extend to Italian in most cases. In (53), the pattern of contrasts shows that participle morphology must alternate identically to the subject for number (and gender). In (54), no morphological alternation is evident in the acceptable examples. (53) contrasts with (54) in that the participle in (53) is conjugated with "etre" while the one in (54) is conjugated with "avoir." The facts are covered by the generalizations in (55).

- 55)a "Etre" participles must agree with subjects
b "Avoir" participles never agree

The sentences in (56) show that agreement or lack of agreement

is not a property that is inherent in participles *per se*.

56)a Il a cassé les assiettes

b Les assiettes sont cassées

"Casser" ordinarily conjugates with "avoir" in *passé composé* constructions as (56)a demonstrates. It does not agree with its subject as (55)b predicts. However, (56)b shows that "casser" participles may agree with subjects in passive constructions where they are conjugated with "être." The generalization in (55)a extends to "avoir" verbs when they are conjugated with "être." In general, the agreement properties of a participle are predictable from the properties of the auxiliary with which it occurs.

The facts in (53), (54) can be predicted from my theory of agreement if "être" participles are in the case domain of the subject of the expression in which they occur but "avoir" participles are not. The difference can be formalized by assuming that "avoir" subcategorizes the case features of its participles while "être" does not. Consider the structures in (57), (58) underlying the acceptable b examples in (53) and (54), respectively.

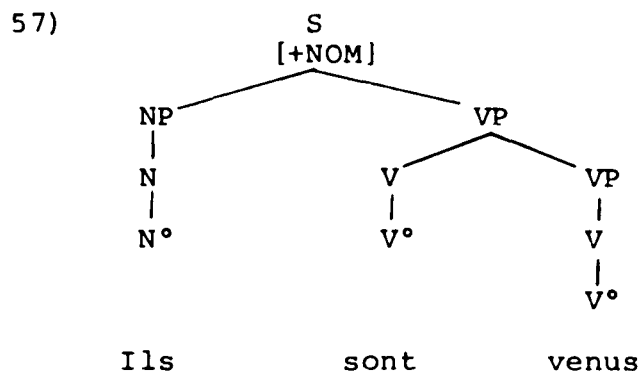

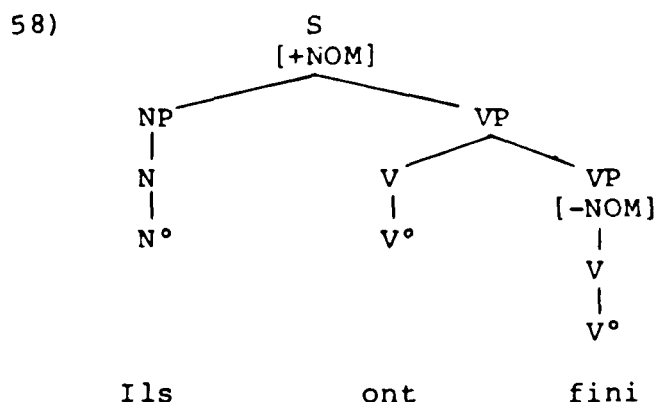

Applying the definition in (52) to (57), (58), δ will be the subject, ϵ will be the participle and σ will be S. In (57), there is no σ' which is a case assigner. The subject and participle are in the same case domain and may constitute an agreement pair if related by Percolation. (58), on the other hand, contains a σ' , the VP subcategorized for [-NOM] by the "avoir" auxiliary. Since the subcategorized VP dominates the participle but not the subject of (58), it follows that the subject and participle are in distinct case domains. Hence, they cannot be related by Percolation under (48) and they cannot be an agreement pair. Assuming then that the structures in (57), (58) are correct, my hypothesis predicts the occurrence of an agreement pair with "être" participles and its absence with "avoir."

The alert reader will have already constructed the principal counterexample to my theory; it is exhibited in (59).

- 59)a *Les assiettes ont été cassé
 b Les assiettes ont été cassées

The examples in (59) show a passé composé of a passive construction. In general, "être's" participle, "été," is conjugated with "avoir." According to theory, it ought not agree

with the subject parallel to the "avoir" participles above.

The unacceptability of (60) validates the entailment.

60) *Les assiettes ont étéées cassées

Taking the examples in structural detail, they have the underlying representation in (61).

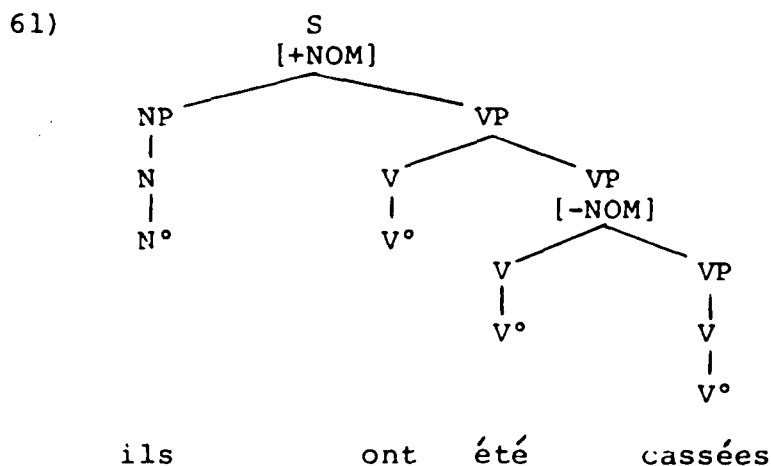

"Été's" lack of agreement properties is predicted because it is in the domain of a subcategorized case feature which the subject is not contained in. Applying (52), "les assiettes" will be δ , "ete" will be ϵ and σ is S. Since "été" is dominated by a case assigning node distinct from S, it follows that it will not agree with the subject. But the same line of reasoning applies to "cassées." Hence, the lack of an agreement pair in (59)a is predicted to be acceptable and (59)b should be ruled out, both counter to evidence.

The problem is solved by considering the D-structure associated with (61), viz., (62).

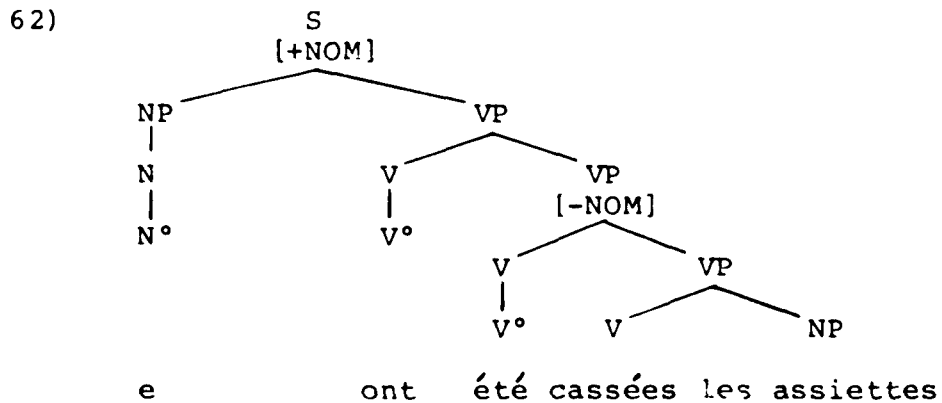

Assuming that (61) is derived from (62) by Move α , the agreement properties of (59)b can be explained. I assume, as is customary, that passive participles do not assign case to their NP complements. Setting δ as "cassées," ϵ as "les assiettes," and σ as VP[-NOM], (52) applies. There is no σ' in (62) such that σ' dominates the participle or the noun but not both. "Cassées" and "les assiettes" may be an agreement pair if Percolation applies prior to Move α .

The example also shows that some other constraints on Percolation must be recognized. "Été" occurs in the same case domain as "les assiettes" but nonetheless does and must not agree with the noun. The facts can be entailed by the theory if Percolation is confined to the c-command domain of the phrasal node in which the percolated feature originates.¹³ "Été" is not in the c-command domain of the direct object and, as a consequence, is inaccessible to Percolation and, hence, Agreement.

It is necessary to consider in more detail some of the properties of participles themselves. In general, participles in the correct context agree with nouns. They fail to assign case to nominal complements. Finally, the

the facts in (63) show that they have a distribution similar to adjectives.

- 63) a Les fleurs rouges
 Les fleurs fletries
- b Les fleurs est rouges
 Les fleurs est fletries
- c Les fleurs semblent rouges
 Les fleurs semblent fletries

The first member of each pair in (63) contains an adjective; the second, a participle. The a pair shows an adjective and a participle as the modifier of a noun in an NP. The b pair shows them in construction with "être." And in c both occur as complements to a raising verb. Generalizing, where an adjective may occur so may a participle. Adjectives also agree with the noun they modify and it is usually assumed, outside of some exceptional cases,¹⁴ that they do not assign case. Obviously, as many researchers like Chomsky (1981),¹⁵ Fiengo and Battistella (1980), etc., have concluded, the parallelism is accounted for if participles are categorially nondistinct from adjectives.

On the other hand, there is a distinction in the class of participles which must be respected. Consider again the case in (56)a.

- 56) a Il a cassé les assiettes

If "cassé" in (52)a were an adjective, two things would be predicted. First of all, it would be expected that (52)a should be ungrammatical parallel to (64).

- 64) *Il est cassé les assiettes

It is customary to rule out (64) on the Case Filter. The lexically realized object is not assigned case by the passive "adjective." Since (56)a is grammatical, its direct object must have some means of receiving case that is unavailable in (64). Second, (65) would be predicted to be a possible agreement structure.

65) *Il a cassées les assiettes

Consider the result in more detail as shown in (66).

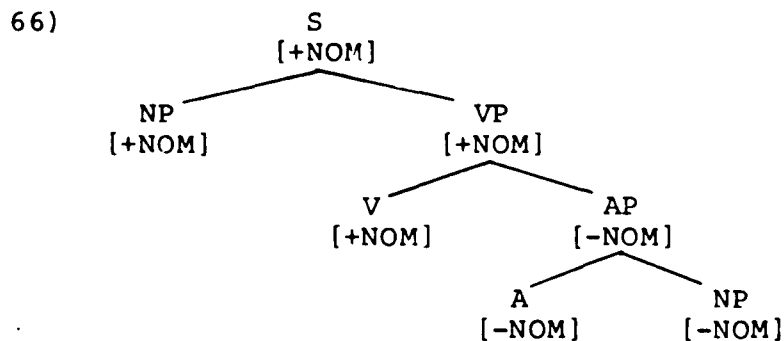

Il a cassées les assiettes

Assume, as is legitimate under the Dropping hypothesis that I have adopted, that the AP in (66) permits its subcategorization feature, [-NOM], to drop onto "les assiettes," thus avoiding the Case Filter. The participial adjective and the direct object occur in the same case domain. Conditions on c-command are met. There ought to be at least the possibility of agreement, but the unacceptability of (65) shows there is not.

The evidence demonstrates that "avoir" participles in conjugation with "avoir" only neither agree with nouns nor fail to assign case to their direct objects. There are some "avoir" participles which are exceptions to the latter generalization; they are intransitive. On the other hand, all

participles in a conjugation with any form of "être" agree with a nominal. Since some of the participles in conjugation with "être" are participles of "avoir" verbs, it follows that "avoir"-taking participles may optionally have agreement properties. I propose to formalize the distinction as (67).

67)a [être, [+___ [+N,+V],...], ...]

b [avoir, [+___ [-N,+V],...], ...]

The lexical representation of "être" shows that it subcategorizes only adjectival complements. Since adjectives agree with nouns, "être," in effect, subcategorizes its complements for agreement inflection. "Avoir," on the other hand, subcategorizes only verbal participles. Lexical insertion of the forms in (67) into a phrasemaker result in (68)a and b, respectively.

68)a

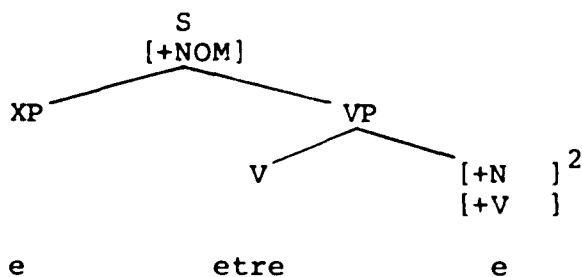

b

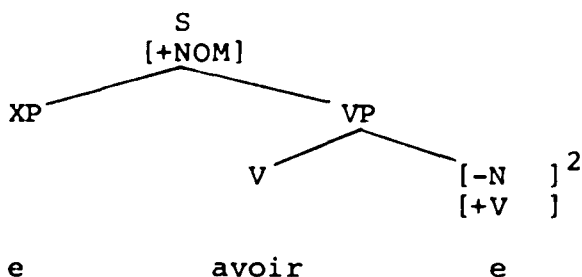

I assume that other applications of lexical insertion will further specify the trees in (68), e.g., nominal features will insert in the subject and direct object slots. Concentrating on the participle position, observe that in (68)a

only a lexical item nondistinct from the features [+N,+V] may insert. Lexical insertion of matrices nondistinct from [-N,+V] is permitted in (68)b. I assume that verbal participles retain case assigning properties. (68)b underlies (56)a and no underlying structure for (65) can be generated.

Consider now the lexical representations of participles and their inflectional parts. Suppose all participles of French have lexical listings of the form in (69).

69) [ϕ , [+V, ...], σ]

Observe that (69) is nondistinct for any nominal feature.

The lexicon also contains the affixes in (70).

70)a [\emptyset , [+] $\begin{bmatrix} [+N]0___ \\ [+V] \end{bmatrix}$ $\begin{bmatrix} [+N]0, -NUM, \dots \\ [+V] \end{bmatrix}$, ...]

b [s, [+] $\begin{bmatrix} [+N]0___ \\ [+V] \end{bmatrix}$ $\begin{bmatrix} [+N]0, +NUM, \dots \\ [+V] \end{bmatrix}$, ...]

c [\emptyset , [+] $\begin{bmatrix} [-N]0___ \\ [+V] \end{bmatrix}$ $\begin{bmatrix} [-N]0, \dots \\ [+V] \end{bmatrix}$, ...]

I assume that the subcategorization features of affixes may contribute categorial features to the syntactic matrices of the lexical items to which they affix. For example, the affixation of (70)c to (69) will yield (71).

71) $\begin{bmatrix} [-N]0 \\ [+V] \end{bmatrix}$ $\begin{bmatrix} [-N]0 \phi \\ [+V] \end{bmatrix}$ [AFF \emptyset]

(71) is a verbal participle without agreement features. The affixation of the forms in (70)a and b to (69) will be inserted into the phrasemarker in (68)a. (68)b will permit the insertion of a lexical form inflected with (70)c but not (70)a or b.

So far the proposal does not sufficiently restrict the distribution of participles. As it stands, it implies

that any participle ought to occur with any verb. But not all verbal forms which cooccur with "être" are found in distribution with "avoir." Since "avoir" requires [-N,+V] adjuncts, it is sufficient to assume that some participles, those which occur only with "être," are [+N,+V]. "Être" participles may be affixed with (70)a and b but not (70)c. "Avoir" participles on the other hand will take all of the affixes in (70) depending on their context.

Further examination of the evidence will show the approach above to be too restrictive. In limited contexts, participles in conjugation with "avoir" but no form of "être" have agreement properties with direct objects. I will turn immediately to consider some cases of direct object agreement with verbal constituents.

I have observed that the French and Italian cases of verbal agreement contain an additional twist, object agreement. While the phenomenon may be marginal for the Romance cases, it is well-attested for other languages. In general, verbs may agree with the direct and indirect objects which they subcategorize. It follows that some grammatical process must be developed for such cases, although, as I will show, it is sometimes questionable that object agreement cases are in fact agreement.

Consider the facts of Mbay as reported by Keegan (p.c.). With respect to number agreement Mbay requires alterations of my theory of subject/verb agreement similar to those for French and Italian "être" participles. Keegan reports forms such as (72) and gives the string analysis in (73).

72) Su a ade yaa keta Ngaba

Su FUT give something to Ngaba

73) NP PER-AUX-NUM PER-V-NUM NP P NP

Su \emptyset a \emptyset \emptyset ade \emptyset yaa keta Ngaba

It can be concluded from the analysis that auxiliaries and adjoined verbs agree with the subject of the clause in which they are contained. The facts can be accounted for if it is assumed that the future auxiliary does not subcategorize its verbal complement as [-NOM]. It follows that [+NOM] drops into (at least some) verbal participles in Mbay. Hence, auxiliaries and "participles" may agree in number and person with the subject.

Further examination of person agreement in Mbay reveals other parallels to the French and Italian cases. Keegan describes the sentences in (74) as having the analyses in (75).

74) Su a adea yaa

Su FUT give him something

75) NP PER-AUX-NUM PER-V-NUM-PER NP NP

Su \emptyset a \emptyset \emptyset ade \emptyset a PRO yaa

The verb in participle position agrees with its direct object when the direct object position contains an empty category.

(73) shows that when both objects are phonologically realized, there is no (phonologically realized) person agreement between object and participle.

Observe that the facts of Mbay imply a difficulty for my theory which does not arise in French and Italian. The participle is marked for subject and object agreement simul-

taneously. But the notion of case domain as presently constituted predicts that such examples should be ill-formed because no constituent appears in two case domains at the same time.

The problem can be resolved if the processes involved in the structure of object agreement in Mbay are not agreement at all. For instance, it can be hypothesized that the distinction between cliticization and agreement is not merely lexical. That is, the two processes are otherwise distinct than the fact that a clitic is a morpheme with distribution depending on syntactically defined properties like second position (cf. Edwards (1980)) while an agreement marker is a bound morpheme whose distribution is identical to the lexical complex of which it is a constituent. From the hypothesis it follows that object agreement in Mbay may be a reflex of cliticization rather than agreement.

There are facts which distinguish Mbay from French and Italian with respect to object agreement. The Romance cases require both a lexically realized pronominal form, a clitic, and agreement features on the participle along with an empty object position. The options in Mbay are more restricted. Either the object NP is empty and the verb marked for object agreement or the object NP is lexical and the verb unmarked for agreement. Other evidence for the distinction between agreement and cliticization is internal to the Romance languages. Consider *wh*-constructions. In French, for example, object/participle agreement may occur when a direct object is *wh*-moved into complementizer position to derive a question or

relative clause. Hence, object/participle agreement occurs in constructions where cliticization is not an issue and such agreement is, hence, independent of cliticization. Furthermore, the distribution of object clitics throughout Romance is quite regular with language-specific variations and French is no exception. However, Fiengo (p.c.) and others point out that object/participle agreement occurs as a historical relic.

Since the evidence appears to show that object agreement in French must be treated as a process distinct from cliticization, I will consider the French facts in more detail. (76) shows the relevant cases.

76)a Il les a cassées

b Les assiettes qu'il a cassées sont sur la table

The examples show that, in general, when the direct object of a verb conjugated only with "avoir" appears on the left of the participle through cliticization or *wh*-Movement, the participle may agree with the direct object.

If the *Port Royale Grammar* treats direct object/participle agreement correctly as Fiengo (p.c.) suggests, then the agreement properties of the participles in (76) must be traced to their adjectival status. It follows that my previous characterization of constructions containing only "avoir" with some participle is too restrictive. I assumed that the lexical representation in (67)b prevented "avoir" from taking adjectival complements.

67)b [avoir, [+___[-N,+V],...], ...]

I deemed the hypothesis necessary to prevent the occurrence

of "être" participles with "avoir."

To make the necessary adjustment to the theory, I will reinterpret the contribution that subcategorization features make to phrasemarkers. The insertion of "avoir" specifies a tree as in (77); the reader may wish to compare (77) to (68)b.

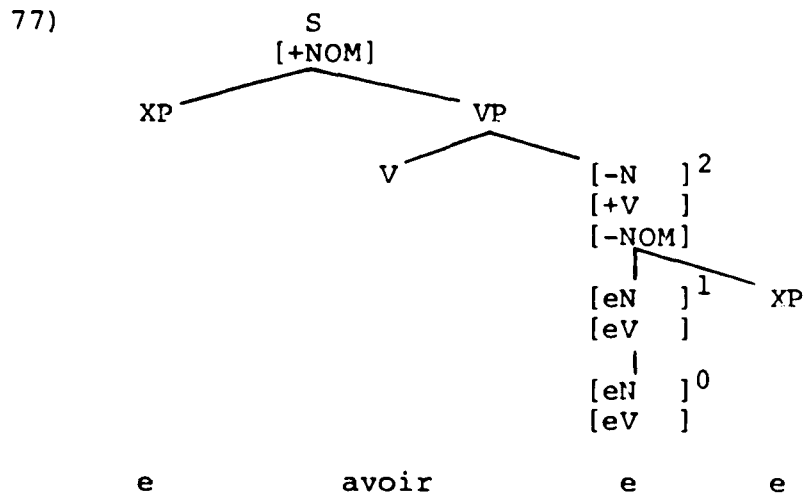

In brief, subcategorization specifies features only at the phrasal level. Categorical specification at other levels occurs by Dropping from the phrasal level or Percolation from the lexical level.

Given the lexical representation of participles and their affixes, any "avoir" participle will take either adjectival affixes (the agreement features, (70)a and b) or the verbal affix, (70)c. Thus, depending on inflectional processes, lexical insertion of a participle plus Percolation will specify (77) as (78)a or b, where "AGR" stands for agreement features and "∅" represents the verbal affix.

78) a

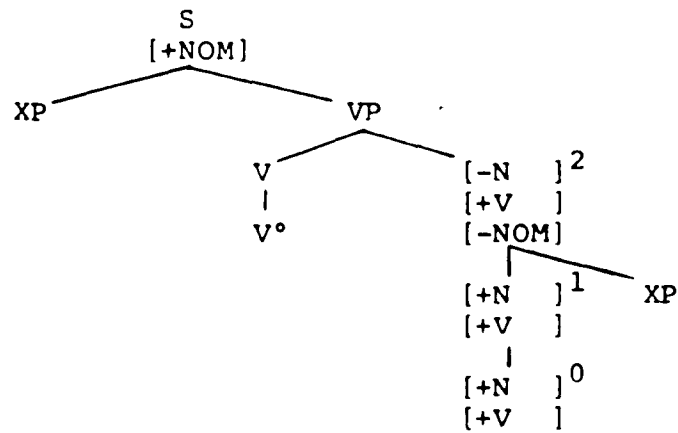

e avoir participle+AGR e

b

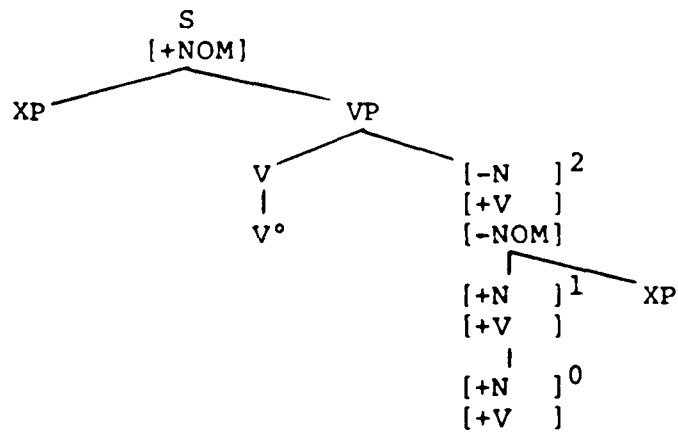

e avoir participle+∅ e

Two problems arise with my revision of the analysis. First, a problem previously observed: what prevents (78)a from underlying the unacceptable (65)?

65) Il a cassées les assiettes

Second, what prevents an "être" participle from inserting in (77) and cooccurring with "avoir."

As was hypothesized previously, (65) can be ruled out by the Case Filter if "les assiettes" fails to receive case. Since adjectival constituents typically do not assign case, the hypothesis for ruling out (65) as a reflex of the Case Filter is plausible. Fiengo and Battistella (1980) propose

that adjectival participles assign the feature [-CASE] to their NP complements to formalize lack of case assignment. Assuming that their formalization can be extended to the construction in (78)a, (78)a's explicit form will be (79).

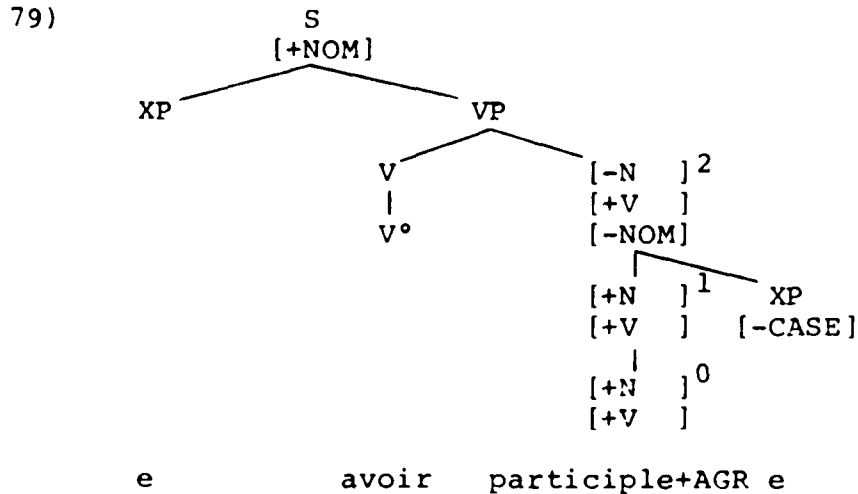

Should "les assiettes" insert in (79) as a direct object complement, the structure will be ruled out by the Case Filter.

Observe that the direct object in (79) cannot be NP-moved to subject position to receive nominative case as it can in passive constructions. Borer (1980) derives the thematic constraint on movement given in (80) from her application of the Thematic Criterion in (81).

80) NP Movement may occur only from a thematic position to a nonthematic position

81)a Each thematic position is assigned a referential expression

b Each referential expression is assigned a thematic role

c Only referential expressions are assigned to thematic positions

The notion "assigned to" in (81) is explicated in (82).

82) A referential expression, α , is assigned to a thematic position, Π , iff:

- i) α has no trace and occupies Π
- or ii) α has a trace which occupies Π

"Les assiettes" is an R-expression. By (81)b, it must receive a θ -role; (81)a guarantees it will be assigned to some θ -position. (79) contains two θ -positions, [NP,S] and [NP,VP]. I assume transitive participles in adjectival form retain the property of assigning two θ -roles. "Les assiettes" will obtain one of those roles and may occur in one of the thematic positions as shown in (83).

83)a [NP e] ont cassées les assiettes

b Les assiettes ont cassées [NP e]

(83)a is ruled out because [NP,S] is a θ -position containing no R-expression and "les assiettes" is [-CASE] in violation of the Case Filter. (83)b is ruled out in a number of ways. If [NP e] is trace, it fails to be bound as required by the Binding Conditions given in (84).

84)a An anaphor is bound in its governing category¹⁶

b A pronominal is free in its governing category

c An R-expression is free

Since NP-trace is an anaphor, it must be bound under (84)a. If it is bound, then it is the trace of "les assiettes." But if it is the trace of "les assiettes," then "les assiettes" is the R-expression assigned to [NP,VP] under (82)ii. As a consequence, [NP,S] fails to be assigned an R-expression as (81)a requires. Hence, (83)b is predicted to be ungrammatical

if [_{NP} e] is trace.

It might be supposed that [_{NP} e] in (83) is PRO. PRO is an R-expression and can be inserted in a thematic position to fulfill (81)a. In (83)a, PRO will be excluded under the theoretical principles which predict the generalization that French (English, etc.) must have phonologically realized subjects. However, no similar principle(s) rule out PRO in [NP,VP]. In fact, Jaeggli's (1980) analysis of clitics depends on the possibility for inserting PRO in [NP,VP].

Before dealing with the problem of ruling out PRO in [NP,VP] in (83)b, consider a related problem. Recall the distribution of object/participle agreement in the frame, [_{VP} ... participle+AGR NP ...], for various values of NP. The pattern of contrast is shown in (85).

- 85)a *... participle+AGR NP ... (where NP is lexical)
- b ... participle+AGR PRO ...
- c ... participle+AGR x ...
- d ... participle+AGR [_{NP} e] ...

(85)a is ruled out on the analysis I have been discussing. Assuming Jaeggli's analysis of clitics, (85)b is associated with (76)a as well as the case I want to rule out. (85)c has a variable in [NP,VP] and underlies (76)b, the *wh*-Movement case. (85)d is associated with passive constructions. While the adjectival analysis permits (85)b and d as desired, it predicts that (85)c ought to be as unacceptable as (85)a. On standard assumptions about *wh*-Movement, if the variable is not assigned case, there is no way for its lexically realized antecedent to get case and constructions containing (85)c

would fail the Case Filter.

Jaeggli's (1980) explanation of clitic generation entails that clitics are the result of case assignment to a nonargument position. Suppose then the distribution of agreement in clitic constructions falls under the generalization in (86).

- 86) Agreement in participles is a reflex of case assignment to some nonargument position.

The assertion in (86) can be extended to cover *wh*-constructions. The position, [COMP, \bar{S}], is generally assumed to be a nonargument position. I hypothesize that the presence of agreement is directly implicated in case assignment to nonargument positions by (87).

- 87) An agreement target may assign case to its source antecedent if its antecedent is in a nonargument position

From (87), it follows that either of the structures in (88) may underly *wh*-Movement cases of participle agreement.

- 88)a ... [COMP wh_i]...[VP...participle+AGR_i PRO_i ...]...
b ... [COMP wh_i]...[...participle+AGR_i e_i ...]...

Because the *wh*-element in COMP receives case directly from agreement by (87), there is no reason for the trace of *wh*-Movement to be cased. The result is consistent with Borer's (1980) argument that variables ought not to be distinguished from trace or PRO by casemarking. So it can be maintained without any problem that participles do not assign case to objects in their complements when they bear agreement markers.

Given Jaeggli's (1980) analysis of complex subject

inversion in French there is independent evidence that coindexing with agreement permits the transmission of case in specified environments. I will not go into detail here.

Observe further that another generalization derives from the forms in (85). In all the acceptable cases of participle agreement, (85)b through d, the nominal with which the nonnominal agrees occurs to the left of the nominal. Baltin (1978) proposes a hypothesis from which the generalization might derive. He assumes the schema in (89) for the construal of modifiers discontinuous from their heads.

89) NP - X - Modifier

That is, at the level of construal, I assume LF, the nominal modified must be to the left of the modifier. I assume that adjectivals modify the nouns with which they agree. Given the adjectival properties of the participles I am investigating, it follows that they modify their direct objects. In short, they fall under the construal schema in (89).

I have already suggested that agreeing participles are coindexed with *wh*-elements in COMP. Suppose then indexing of agreeing participles is extended to all the cases in (85)b through d to give (90).

90)a ... participle+AGR_i PRO_i ...

b ... participle+AGR_i x_i ...

c ... participle+AGR_i e_i ...

I formalize the construal schema in (89) as approximately (91).

91) A modifier must be coindexed with a constituent to
its left

All of the forms in (90) meet the condition in (91) as (92)

shows.

- 92) ... clitic_i ... participle+AGR_i PRO_i ...
... wh_i ... participle+AGR_i x_i ...
... NP_i ... participle+AGR_i e_i ...

In every case, the element coindexed to and modified by the participle appears to the left.

Recall now the form of (83)b. Assuming that the construal of modifiers is marked by coindexing and that adjectival transitive participles modify direct objects, (83)b will have the indexed form in (93).

- 93) Les assiettes ont cassées_i PRO_i

But (93) contains no constituent to the left with which the participle can be coindexed to meet (91). If the subject is coindexed with the participle, (94) is the resulting form.

- 94) Les assiettes_i ont cassees_i PRO_i

In (94), PRO ends up coindexed with "les assiettes." If PRO is pronominal, as seems plausible, then it is bound in contravention to clause (b) of the Binding Conditions.¹⁷

One comment on the solution is necessary. The execution I have employed tacitly assumes that agreement indices and referential indices are identical. The assumption is controversial as an examination of Chomsky (1981), Jaeggli (1980), Hyams (1980) and others would show. I will give an explicit formalization of agreement indexing in Chapter IV and defend the assumption of identity with referential indices there.

Before returning to the problem of "être" participles, I would like to consider in detail the application of (52)

to clitics and traces of movement. Consider the forms in (95).

95) a

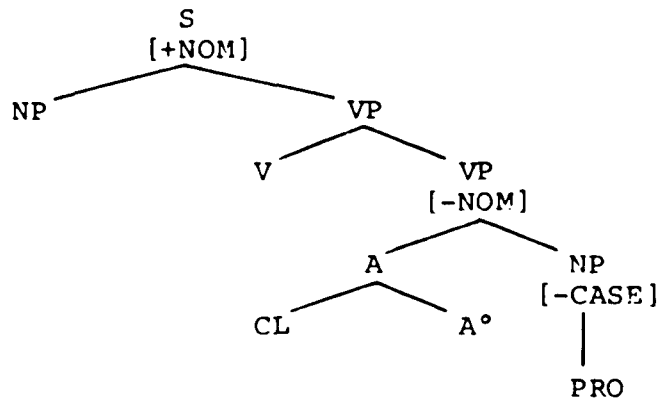

b

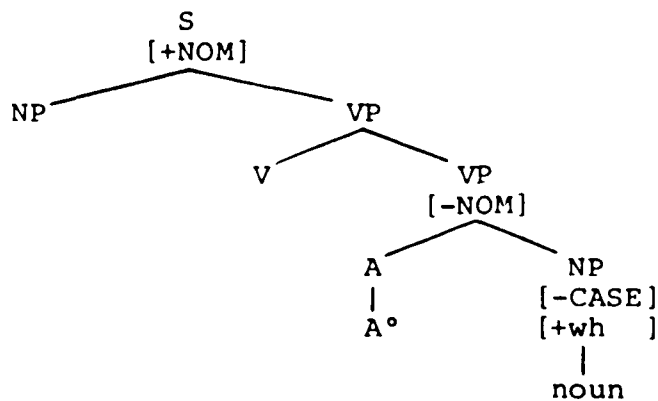

The clitic form in (95)a is unproblematic. Take the clitic as δ in (52), the participle as ϵ and VP[-NOM] as σ . VP[-NOM] is a case assigner and there is no σ' as (52)ii requires. Thus clitic/A° may be an agreement pair if they are related by Percolation.

(95)b shows the pre-Movement form for a *wh*-construction. The problem I see also extends to passive constructions so I am discussing (95)b as an illustration. Consider the question of whether NP[-CASE] constitutes a σ' to VP[-NOM] in the sense specified by (52). If lack of case were simply the failure of any case specification as is usually assumed by Chomsky (1981) *et al.*, the application of (52) would be clear. [-CASE], on the other hand, has the properties of a

feature distinct from other case features. First, it blocks Dropping. If [-CASE] were nondistinct from other case features, Dropping would be permitted into [-CASE] nodes as if they were unspecified for case. Hence, it might be argued to dominate a case domain distinct from the domain containing A° in (95)b. I will simply stipulate here that a node marked for [-CASE] does not constitute a case assigner like inherently cased nodes or nodes subcategorized for case. Thus, NP[-CASE] will not count as a σ' for (52)ii. It follows that A° and the direct object in (95)b are in the same case domain by (52) and may agree if related by Percolation prior to Move α .

The problem of excluding "etre" participles from the context of "avoir" as shown in (77) is still outstanding. I will adopt and adapt the solution proposed by Hyams (1980). She argues that, in Italian, "essere" participles cannot occur with "avere" due to the thematic properties of the verbal elements involved. I will alter the hypothesis to suit French and the version of Thematic Theory I have assumed.

Hyams asserts that as an auxiliary "avere" retains at least one of its transitive thematic properties. It assigns a θ -role to subject position. She then observes that "essere" assigns no θ -role to subject. I will carry these assumptions over to the French verbs by saying that "avoir" takes subject as a θ -position while "être" does not.¹⁸

I then assume that "être" participles, being intransitive, have one θ -role to assign. I will further assume that they must subcategorize their θ -position. The latter stipulation forces "être" participles to insert in either of

the frames in (96).

96)a [_{XP} NP [_A ...]]

b [_{XP} [_A ...] NP]

XP will be a maximal projection of [-N,+V] or [+N,+V] depending on context. "Etre" constructions will have a raising form as argued for by Stowell (to appear) and shown in (97).

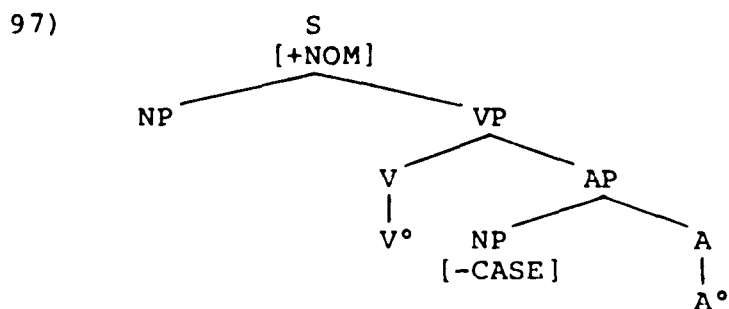

The θ -position at [NP,AP] in (97) must be assigned an R-expression to meet (81)a. But no R-expression may obtain case at [NP,AP]. However, an R-expression is accessible to [+NOM] in [NP,S]. Move α will move the R-expression from [NP,AP] to [NP,S] leaving a trace. By (82)ii, then, the θ -position will be assigned an R-expression satisfying (81)a and the Case Filter will be circumvented.

By way of contrast, "avoir" participles will have one or more thematic roles to assign depending on whether they are intransitive or not. Furthermore, they do not necessarily select θ -positions by subcategorization. Consider the case of an "avoir" intransitive. One of the properties of "avoir" is that it takes subjects as a θ -position. Thus, in an "avoir" construction, the subject must contain an R-expression. The intransitive participle will assign its single thematic role to the R-expression in [NP,S].

Consider now the insertion of an "être" participle in an "avoir" construction like (77). The result will be (98).

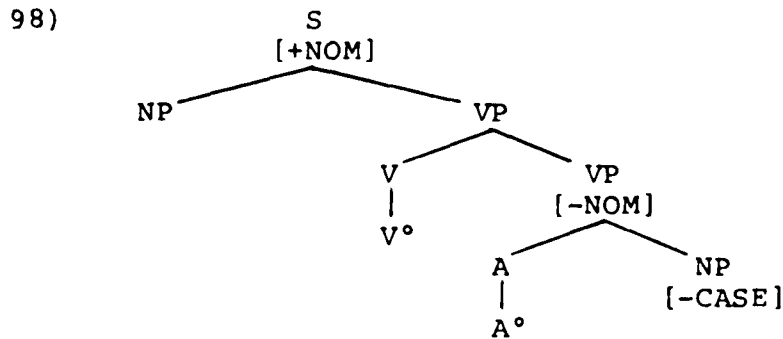

avoir participle

By hypothesis, (98) will contain two thematic positions, one selected by "avoir," the other subcategorized by the "être" participle. By (81)a, both must contain an R-expression. (81)b requires each R-expression to be assigned a θ -role. However, the intransitive "être" participle has only one θ -role to assign. So either (98) must contain two R-expressions only one of which is assigned a thematic role in contravention to (81)b or it will have one R-expression with a θ -role and fail to satisfy (81)a. (98) is ruled out; "être" participles cannot occur in conjugation with "avoir" only.¹⁸

I have now concluded my investigation of the agreement properties of French participles.

Putting aside agreement with objects in VP, I will take up in more detail the agreement of subjects with other constituents of VP. Consider, for example, the agreement of subjects with constituents in predicative constructions as in (99), (100).

99)a L'homme est tres intelligent

*L'homme est tres intelligents

- b *Les hommes sont tres intelligent
Les hommes sont tres intelligents
- 100)a The woman is a good lawyer
*The woman is good lawyers
- b *The women are a good lawyer
The women are good lawyers

Two questions will emerge with respect to predicative constructions. The first is whether such structures, in general, can be brought under the Percolation account of agreement. The second is whether the account which covers predicate adjectives such as exemplified in (99) can be extended to the predicate nominals shown in (100).

In my previous consideration of "être" participles, I supposed that "être" has two properties. It strictly subcategorizes adjectivals but fails to subcategorize case. Because adjectivals may be inflectionally identical to the constituents they modify, as evidenced by NP-internal adjectives modifying the head nouns of NP's in which they occur, they may occur as members of agreement pairs. The case pass-along property of "être" permits its participles to occur in the same case domain as the subjects of the sentences containing them. Hence, Percolate α may relate subjects to participles in an agreement pair. Since the analysis in part depends on the adjectival properties of verbal "être" complements, it should extend straightforwardly to nonverbal adjectives.

The problem is that the analysis of "être" so far proposed fails to give an account of subject/predicate adjective

agreement in passe compose constructions like (101).

- 101)a L'homme a été tres intelligent
 *L'homme a été tres intelligents
- b *Les hommes ont été tres intelligent
 Les hommes ont été tres intelligents

The problem parallels that discussed with passive participles in compose constructions. "Avoir," unlike "être," does subcategorize case features for its participles. As expected, "été" does not agree with the subjects of the examples in (101). However, the adjective does.

On the analysis I have proposed, the agreement of predicate adjectives with subjects is unexpected. Observe (102), a possible underlying structure for (101)b.

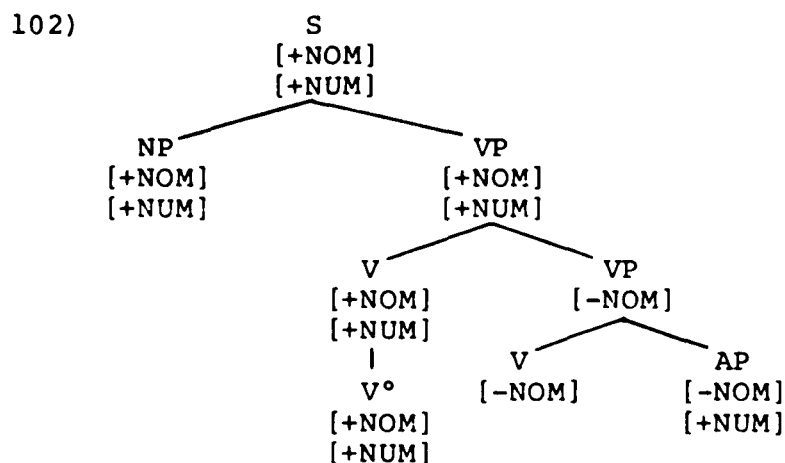

Les hommes ont été tres intelligents

Given the constraint on Percolation in (48), [+NUM] cannot copy from the maximal VP in (102) onto the VP it dominates. But if [+NUM] cannot copy onto the dominated VP, then there is no percolation source for [+NUM] in the AP which the dominated VP immediately dominates. Hence, Percolation does not account for the agreement relation in expressions con-

taining predicate adjectivals if the structure in (102) is correct.

Stowell (1978, to appear) offers a raising analysis of predicative constructions on which the consequences implied by (102) can be avoided. In Stowell (to appear), he argues extensively that all syntactic categories may have subjects. Given the subject hypothesis, (102) may be reanalyzed as (103), abstracting away from case assignment.

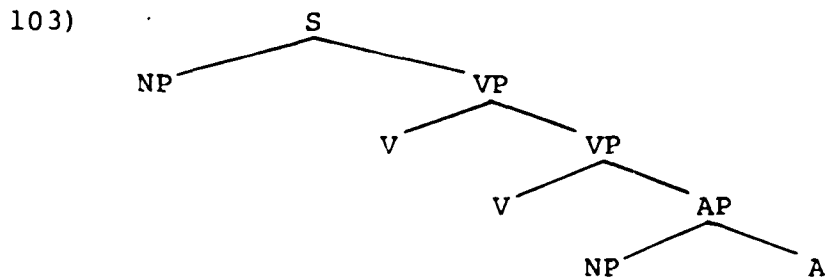

Les hommes_i ont été e_i tres intelligents

The D-structure associated with (103) is (104).

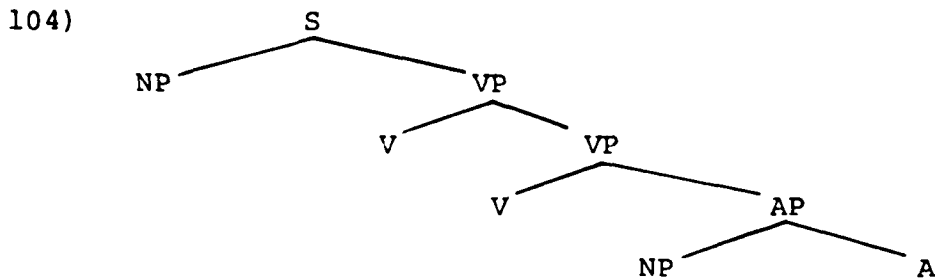

e ont été les hommes tres intelligents

If Percolation applies prior to Move α (as well as subsequently to explain subject/verb agreement) in (104), then, providing other conditions are met, agreement in predicate adjectivals can be subsumed under the theory I am proposing. The solution is essentially like the one proposed for passive participles above.

The crucial condition which must be met is that "les

hommes" and "intelligents" in (104) be in the same case domain. Case Dropping Theory predicts the case configuration in (105) is assigned to (104).

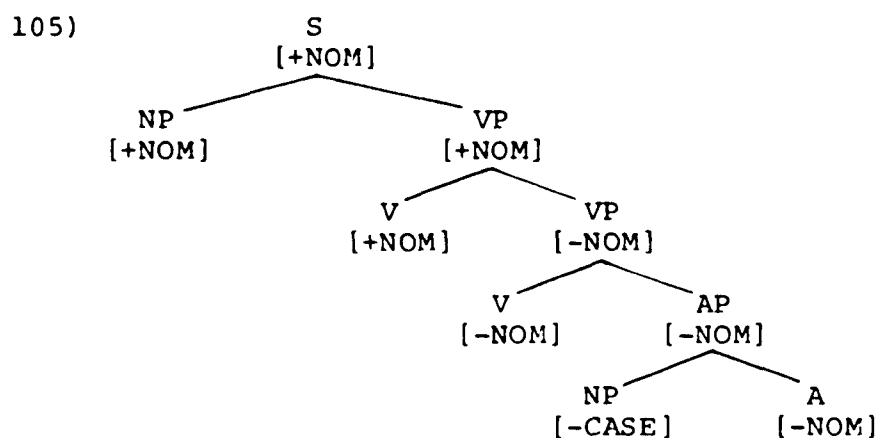

Given my stipulation that a node assigned [-CASE] does not count as a case assigning node, NP[-CASE] and the head of AP will be in the same case domain. Hence, Percolation may occur. Because case is not assigned to [NP,AP], any lexically realized NP generated there must be moved to a cased position such as subject of S in (105).

A problem arises where the subject position in (105) is filled by a nonreferential constituent as in existentials (in English) or presentational constructions (French). Since, the constituent in [NP,S] is nonreferential, it need not be assigned a θ -role. The post-verbal NP will be; one property of "to be" type verbs is the assignment of thematic marking to the complements but not the subjects of VP's in which they occur. It is commonly observed that post-verbal NP's are nominatively casemarked, contrary to the [-CASE] marking shown in (105). I assume, following a suggestion of Borer (1979), that case is assigned to such NP's by idiosyncratic

lexical marking. Following Aoun (ms.) such marking is to be distinguished from abstract case. Abstract case is the case assigned by the theory of Dropping I have assumed. It is abstract case that determines case domains. NP's in postverbal position will receive abstract case as shown in (105). Nominative casemarking will follow from other devices.

Having dealt with the particulars of predicate adjective constructions, I conclude that the percolation treatment can be suited to subject/predicate adjective pairs. The question is open as to whether the account can be extended to predicate nominals in English.

The extension of my treatment of predicate adjectives to predicate nominals can be accomplished by adopting a small clause analysis of the sort initially proposed in Williams (1975) and taken up by Chomsky (1981) and Stowell (1981). Consider the structure in (106) as underlying (100)b.

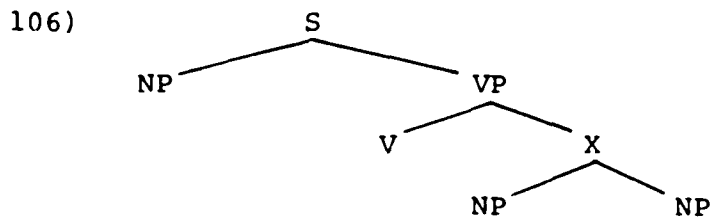

The women_i are e_i good lawyers

The small clause analysis takes advantage of the raising properties of copular verbs in the same way as did the analysis of predicate adjectives. Agreement occurs at at point where both constituents occur in the same case domain, i.e., prior to movement. In this case, the problem is to come to some conclusions about the properties of X.

Given my description of the subcategorization proper-

ties of copular verbs, X can be categorially specified as [+N,+V]. In this case, feature specification derives directly from subcategorization rather than Percolation from a lexical category. Second, it may be concluded that X is not the maximal projection of any category. Consider the effects of the ECP in (106). [_{NP} e] must be properly governed, either by the copular verb or the predicate nominal. But the head of the predicate nominal cannot properly govern the trace because by definition of government a maximal projection is an absolute boundary to government. NP cannot properly govern the trace because proper governance requires a lexical category. Hence, by process of elimination, [_{NP} e] must be properly governed by the copula. Accordingly, X cannot be a maximal projection of [+N,+V].

Other evidence supports the conclusion. Consider the sentences in (107).

- 107)a John considered the women good lawyers
- b John considered them good lawyers
- c *John considered they good lawyers

Chomsky (1981) and Stowell (1981) analyze "consider's" complement as a small clause. The acceptability of (107)a,b shows that subjects of small clauses may receive case by some device. The unacceptability of (107)c shows that case is [-NOM]. Given that "consider" is a verb which ordinarily assigns [-NOM] case to nominal complements as in "John considered them," it is plausible to believe that it assigns case to the subject of the small clause. Given that on the Government/Binding framework, case is assigned into verbal

complements by government, it follows that [-NOM] must be assigned to the subjects of small clauses by government. But government would be blocked if a small clause were the maximal projection of some category. They conclude small clauses are not maximal projections.

Consider Movement out of the complement of the "consider" construction. There is observed the contrast in (108).

108)a *They_i considered [_X e_i good lawyers]

b They_i were considered [_X e_i good lawyers]

Movement is ruled out in (108)a by the generalization in (80). But it is permitted in (108)b. Again, "consider" must be able to properly govern the trace in [NP,X] because "good lawyers" cannot. But if "consider" is the proper governor, X cannot be a maximal projection. I conclude that a small clause is not a maximal projection.

There is a problem occasioned by the small clause analysis for which I do not have a complete solution. Clearly, the sentences in (109) are unacceptable on the declarative reading.

109)a *Are the women good lawyers

b *Are women good lawyers

In some sense, the examples simply parallel the adjectival cases like "[_{NP} e] are the women tall." But in those cases, NP Movement was forced by subcategorization of [-CASE] at [NP,AP]. However, locality conditions on subcategorization prevent the same solution in the frame in (110).

110) [_X NP NP]

In short, insofar as the head of the predicate nominal cannot

govern the subject of the small clause it cannot subcategorize it either. Furthermore, the acceptability of (107)a,b shows that [-NOM] must be able to drop into subject position of small clauses on at least some occasions. One might be tempted to rule out (109) as instances of violations of the principle(s) preventing phonologically null subjects in English but it must be observed that (111) is no better.

111)a *There are the women good lawyers

b *There are women good lawyers

Some combination of the Definiteness and Predicate Restrictions observed by Milsark (1977) and others might rule out the examples in question, but it is not clear to me how. Further research is required.¹⁹

I will make one final point concerning predicate nominal constructions. Consider the cases in (112).

112)a The women are a fine group

b The women are fine groups

Although the subject in (112)a is plural, the predicate nominal is singular. However, it is a singular NP which in an argument position would denote what is arguably a plurality. Furthermore, the inflectional marking of the predicate nominal is not merely arbitrary with respect to interpretation. In (112)a, "the women" denotes a single plurality or one group. In (112)b, however, the predicate must individuate its subject into several groups. Thus, agreement in predicate nominals appears to be affected by semantic considerations. I will discuss this further in Chapter IV.

To conclude my investigation of the interaction of

Percolation and number inflection, I want to observe an obvious counterexample to the theory I am proposing. So far I have discussed cases of agreement between NP and some constituent external to NP. Now I want to look at the properties of some NP-internal constituents from the class of specifiers and NP.

Turning my attention to SPEC and nominal subjects, I will assume following Fiengo and Battistella (1980) that SPEC is [-N,-V] and inherently cased. The case dropped from SPEC is interpreted as genitive ([+GNT]). My concern is with the agreement properties of constituents in SPEC. As it is presently stated, the theory entails that SPEC and the head of NP are in distinct case domains. It follows that there ought no be agreement pairs like (SPEC of N°,N°).

English has clear counterexamples to the prediction.

(113) shows the relevant facts.

- | | | |
|-------|------------|-------------|
| 113)a | this cat | that cat |
| | *these cat | *those cat. |
| b | *this cats | *that cats |
| | these cats | those cats |

The contrast in grammaticality in the examples shows that the demonstrative specifiers have agreement properties counter to expectation under the complex of hypotheses I have assumed. French provides additional cases. Not only do demonstratives agree with the head of NP, so do definite and indefinite determiners, some quantifiers, and pronominal subjects as (114) shows.

- | | | |
|-------|-------------|--------------|
| 114)a | son livre | leur livre |
| | *ses livre | *leurs livre |
| b | *son livres | *leur livres |
| | ses livres | leurs livres |

The pronominal subjects are themselves marked for genitive, alternate identically to the head noun for number and exhibit an agreement morpheme. Because the pronouns are overtly marked for genitive, there is no doubt that the subject of the nominal and the nominal are in distinct case domains where the nominal serves as the subject or object of a clause.

In English, (nonnominal) specifiers fall informally into two broad categories, determiners and quantifiers. Determiners have one major subclassification, definite, [+DEF], and indefinite, [-DEF]. Among the definite determiners I include the list in (115); [-DEF] determiners are shown in (116).

115) the, this, these, that, those

116) a, sm, Ø

"The" occurs with any noun irrespective of inflectional marking for number. The demonstratives have agreement properties. The simplest way to explain the facts is to assume SPEC can be differentiated for [α NUM] as in (117).

117)a	... [SPEC ...] ...	b	... [SPEC ...] ...
	[+DEF]		[+DEF]
	[-NUM]		[+NUM]

Assuming that "the" has the lexical listing in (118) it will insert in (117)a or b.

118) [the, [+SPEC,+DEF,...], ...]

"This," "that" and "these," "those" will have the lexical representations in (119)a and b respectively.

- 119)a [this, [+SPEC,+DEF,-NUM,...], ...]
[that, [+SPEC,+DEF,-NUM,...], ...]
b [these, [+SPEC,+DEF,+NUM,...], ...]
[those, [+SPEC,+DEF,+NUM,...], ...]

(119)a will insert into (117)a; (119)b, into (117)b.

Now consider the distribution of [-DEF] determiners.

(120) gives the relevant facts.

- | | | | |
|-------|---------|---|----------|
| 120)a | a hat | b | *a hats |
| | *sm hat | | sm hats |
| | *∅ hat | | ∅ hats |
| c | *a mud | c | *a beans |
| | sm mud | | sm beans |
| | ∅ mud | | ∅ beans |

The pattern of contrasts shows that with respect to the distribution of [-DEF] determiners count plurals group with mass nouns. Furthermore, the lack of contrast between the c and d examples shows that the determiner system associated with mass nouns is indifferent to the inflectional marking of the head of the NP.

The other class of specifiers, the quantifiers, exhibit distributions similar to those of the determiners. Thus, there are singular quantifiers, plural quantifiers, and mass quantifiers as shown in (121).

121)a	every hat	b *many hat	c *much hat
	*every hats	many hats	*much hats
	*every mud	many mud	much mud
	*every beans	*many beans	much beans

The reader must be careful to consider only mass interpretations of "mud" and "beans" to assess correctly the judgments. Availing myself of the lexical features for nominals discussed in Chapter II, the quantifier classes observed in (121)a,b,c, can be represented by (122)a,b,c, respectively.

122)a	... [SPEC ...] ...	b	... [SPEC ...] ...
	[+Q]		[+Q]
	[+CNT]		[+CNT]
	[-NUM]		[+NUM]
c	... [SPEC ...] ...		
	[+Q]		
	[-CNT]		

If it is stipulated that SPEC must be nondistinct in number features from the head noun of the NP of which it is an immediate constituent, the pattern of grammaticality in (121) can be accounted for on the basis of formal representations. In general, the distribution of quantifiers can be determined by features associated with nouns by lexical listing or inflectional affixation.

Returning now to the distribution of [-DEF] specifiers, the facts I have observed are explained by assuming some interaction between count and number inflection features. While (123) captures the description of the singular indefinite article, "sm,∅" require the dual specification in (124).

at all and do not count as counterexamples to my definition of an agreement pair.

Returning briefly to a comparison of the French and English specificational systems, observe that both languages have "agreeing" articles. In French, there is extensive phonological realization of inflectional marking while English exhibits a more abstract morphological marking system. But both languages require inflectional marking of determiners and quantifiers to account for distributional properties of SPEC. The difference between French and English is more pronounced when the pronominal and nominal specifiers of NP are observed. English permits both pronominals and full nominals to appear as subjects of NP's. There is no relation between the inflectional marking of nominal and pronominal subjects in NP and the head of NP. The subject paradigm for NP's is, in French, more restricted. It exhibits only pronominal genitive subjects which are inflectionally identical to the head of the NP. Full nominal subjects are prohibited.

The difference might be explained by assuming that French permits no subject, nominal or pronominal, in the SPEC position of NP. The generalization can be entailed by hypothesizing that SPEC in French is not inherently [+GNT]. Thus an NP like (125) will be ruled out by the Case Filter.

125) *Jean livre

The question arises as to why (126) is acceptable.

126) son livre

I assume that the agreement properties of the pronominal indicate that it is in the same case domain as the head

noun and, in fact, receives case when it is dropped into the NP. In the contextual circumstances, the dropped case is interpreted as [+GNT]. The lexical NP in (125) cannot receive case via similar means due to another aspect of agreement already noted, coindexing. That is, agreement results in the indexing of the forms in (125), (126) as (127)a and b, respectively.

- 127)a Jean_i livre_i
b son_i livre_i

Suffice it to say here that the indexing in (127)a is forbidden by Williams (ms.) NP_i/NP_i constraint which will be discussed in more detail in Chapter IV. The reason that (127)a does not similarly violate the constraint is that "son" is not an NP. Genitive pronouns turn out to be possessive adjectives in analyses such as Langacker (1968) and in more classical grammars like Sandfeld (1970). More recently, Kayne (1975) has investigated their clitic-like properties.²⁰ Either way the point is that English has [+GEN] SPEC's while French does not.

To conclude this chapter, I would like to reconsider the effects of (15) as a constraint on agreement pairs and compare it with the theory I have proposed.

- 15) Every agreement pair (α, β) is such that α governs β
or β governs α

First, if agreement is constrained by (15) then it follows that some values of β are bound morphemes attached to no stem at some level of the grammar, viz., INFL. An additional rule is required to represent the lexical realization of INFL

as an inflectional affix to verbs. No other case of agreement covered by Government Theory requires the rule. My theory assumes that agreement is the outcome of a unified rule subject to (128).

128) Every agreement pair (α, β) is such α, β are
lexically realized

There is some evidence that (128) has its exceptions in PRO-Drop languages. But at least some analyses of PRO-Drop under Government Theory such as Hyams (1980) entail that PRO features be inserted lexically. Because predicate adjectivals and nominals do not govern their subjects, (15) excludes those cases of agreement. I have proposed, if in no great detail, an assimilation of predication cases to the framework of my hypotheses. Both theories adequately cover (object, verb), (preposition, prepositional object) and NP-internal (noun, adjective) pairs. (15) includes (SPEC(N°), N°) pairs while the conditions I have elaborated exclude them.

In the concluding chapter, I will return to the subject of agreement indexing and investigate what further constraints it places on the distribution of agreement pairs.

Footnotes

1. For the purposes of exposition, I use the classical notation for the phrasestructure rules. I will return to the theory of the categorially neutral base adopted in Chapter II below.
2. (3)b is consistent with my theory in the sense that [α NUM] is inherent only in nominal categories and elsewhere specified by agreement.
3. [α PRO] is here used as a cover symbol for the inflectional features of number, person and gender.
4. The use of the variable coefficient " α " is meant merely to show that the inflectional features associated with the subject NP and the tense morpheme are identical.
5. Cf. p. 63 below for a definition of proper government.
6. Williams (1981) offers an alternative on which S is headed by the feature [+TNS] from its position in the VP. My initial definition of Percolation, borrowed from Safir (to appear) rules out any such possibility.
7. Cf. Chomsky (1981), Safir (ms.) and others for extensive discussion.
8. Cf. Safir (to appear).
9. Cf. Chomsky (1981) as well as Koster and May (to appear) for extensive arguments as to the constituency of S.
10. The ungoverned property of PRO follows from the Binding Conditions discussed below if it is assumed that PRO is a pronominal anaphor.
11. I assume that the feature [+TNS] is added to the stem of the verb "have" by some lexical process other than affixation.
12. Case features will be affixed to lexical items in the lexicon by processes similar to those examined for other inflectional features in Chapter II.
13. Cf. Reinhardt (1976) for a definition of c-command domain.
14. Cf. Reimsdijk (1980).
15. Chomsky (1981) distinguishes between lexical and syntactic passives via categorially specifying the former as [+N,+V] and the latter as [+V]. I do not go into the matter

of the distinction but the reader will find that my theory of the lexical specification of participles consistent with Chomsky's.

16. I simply take the governing categories to be NP and S, although more abstract definitions are available in, for instance, Chomsky (1981).

17. Ken Safir (p.c.) points out that PRO may be excluded from the position indicated by government if PRO is assumed to be a pronominal anaphor. This solution assumes, however, that PRO in (94) is in a governed position. Given Stowell's (to appear) analysis of the predicative expressions in (i), it is not clear to me that A° does govern the position.

- i) a John left the room [_{AP} PRO [_A angry]]
- b John ate the meat [_{AP} PRO [_A raw]]

Thus, I will stick with the solution I have proposed, which rests only on the pronominal properties of PRO.

18. Ken Safir (p.c.) suggests a similar solution based on having "avoir" require participles with an external θ -role. "Être" participles have no such θ -role. I achieve the same results by stipulating the subcategorization feature of "être" participles. Neither of the solutions is very satisfactory when it considered that verbs corresponding to "être" participles appear to assign θ -roles to subjects when not in conjugation with "être." Hyams (1980) and others resolve this problem by claiming that "to be"-type intransitives assign their thematic role to a VP complement. When the NP appears in subject position rather than postverbally the structure has been derived by movement. Further note that none of these solutions, my own included, entails that "avoir" does not require a subject θ -position or an external θ -role when in construction with "été."

19. Cf. Stowell (1978) for some further discussion.

20. Cf. Elliott (ms.) where it is extensively argued that French possessive pronouns are clitics rather than adjectives.

Chapter IV
Agreement and Interpretation

Moravcsik (1978) reports that one generalization holds universally for agreement pairs: "... all constituents that agree with nominals ... are understood as including reference to the nominal" (p. 363). Examples are not difficult to come by in many languages as (1) shows.

- 1)a Ces fleurs, vous les trouverez fletries
 These flowers, you them will find wilted
- b Kurdu-jarra-rlu ka-pala maliki wajilipi-nyi
 child-DUAL-ERG PRES-DUAL dog chase-NONPAST
 wita-jarra-rlu
 small-DUAL-ERG

"The two small children chase the dog"

In both of the examples there is an adjectival constituent discontinuous from the noun which it modifies. In (1)a, "fletries" is construed with "ces fleurs;" in (1)b, a Walbiri case reported in Hale (ms.), "wita-jarra-rlu" with "kurdu-jarra-rlu."

It is customary to mark construal of discontinuous constituents with coindexing. For example, structures of English like (2), with coindexing between subject and object, are interpreted as underlying expressions of reciprocity or reflexivity.

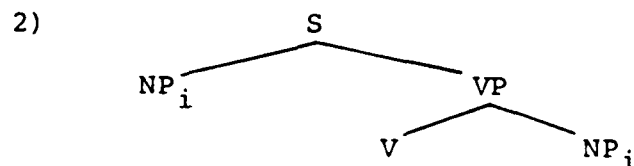

Assuming that the construal of the modification relations exhibited in (1) is syntactically formalized by coindexing, the examples of (1) will have the (approximate) forms in (3).

- 3) a Ces fleurs_i, vous les trouverez fletries_i
 b Kurdu-jarra-rlu_i ka-pala maliki wajilipi-nyi
 wita-jarra-rlu_i

In the discussion that follows I will investigate the interaction of agreement, the assignment of indices such as those in (3) and conditions on distribution of the coindexed pairs which result.

Consider in more detail the case in (1)a. It might be analyzed as an example of Topicalization following Chomsky (1977). The syntactic structure associated with (1)a on a Topicalization analysis is (4).

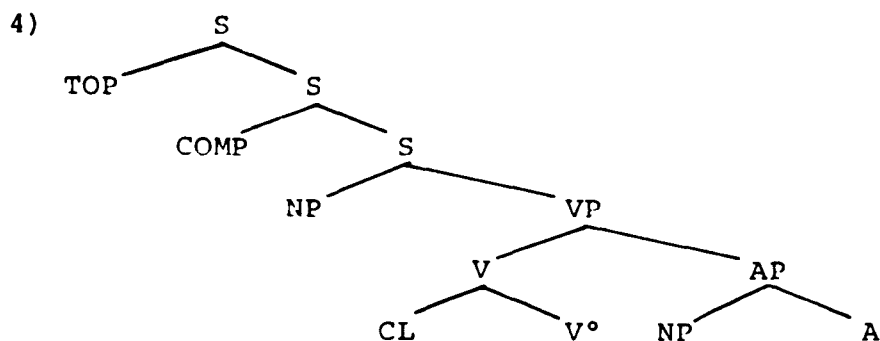

Ces fleurs wh_i vous les trouverez e_i fletries

Observe that I am assuming Stowell's (to appear) analysis of "small clauses," i.e., the bracketed constituent in (5).

- 5) Vous trouverez [les fleurs fletries]

You will find the flowers wilted

Assuming a movement analysis, (4) derives from (6).

- 6) Ces fleurs, [COMP e] vous les trouverez wh fletries
 I ignore for the moment the additional problems induced by

the presence of the clitic in (6).

Given (6) the coindexing of "fletries" can be derived by Percolation from the unmoved *wh*-element. First, as Jaeggli (1980) proposes, abstract *wh*-features are associated with inflectional features, a situation which I notate as "*wh*-PRO." (7) shows the effects of Percolation in AP prior to *wh*-Movement.

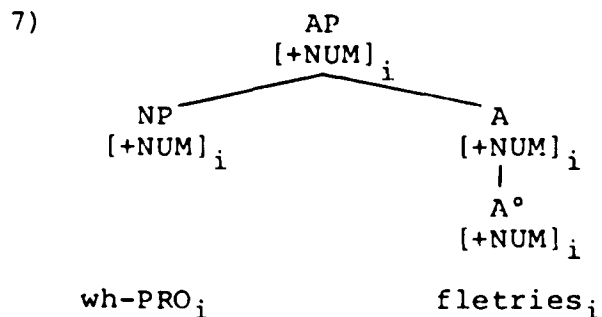

For the moment, I informally assume that to an inflection feature, [α F], there is assigned an alphabetic subscript, "i," "j," etc., for [α F]_i. Percolate α copies the index as well as the feature. Assume that a rule similar to that relating the heads of relative clauses to the *wh*-element in COMP of those clauses functions between TOP and COMP. An approximation is given in (8).

$$8) \quad [_{\text{TOP}} \text{NP}] [_{\text{COMP}} \text{wh}_i] \rightarrow [_{\text{TOP}} \text{NP}_i] [_{\text{COMP}} \text{wh}_i]$$

Given Percolation, Movement and (8), (4) will be indexed entirely as desired. (9) shows the yield informally.

$$9) \quad [_{\text{TOP}} \text{Ces fleurs}_i] [_{\text{COMP}} \text{wh-PRO}_i] \text{ vous les trouverez} \\ e_i \text{ fletries}_i$$

The adjectival constituent discontinuous from the topic ends up coindexed for the correct construal via agreement.

Jaeggli (1980) argues extensively that Movement may

not occur from positions related to a clitic. Thus, the analysis given above seems doomed. He does, however, report similar constructions in Spanish and analyzes them as Left Dislocations. The crucial difference between Topicalization and Left Dislocation is that there is no movement in the latter structures. The constituent in topic position is related directly to the clause modifying it by a rule of predication.

On the analysis of (1)a as a Left Dislocation, the clitic is treated as a resumptive pronoun. Assuming Jaeggli's (1980) analysis of clitics, (10) serves as an approximation of the structure of (1)a.

- 10) [_{TOP} Ces fleurs]_i [_{COMP} e] vous les trouverez
 [_{AP} PRO_i fletries]_i

Percolation yields (11).

- 11) [_{TOP} Ces fleurs]_i COMP vous les trouverez [_{AP_i} PRO_i
 fletries_i]_i

Construal requires further indexing. Suppose that the rule of predication picks up the agreement index of AP and assigns it to "ces fleurs" for (12).¹

- 12) Ces fleurs_i COMP vous les trouverez [_{AP_i} PRO_i
 fletries_i]_i

Jaeggli observes that the predication rule can operate only when agreement conditions are met. Thus, (13) is ill-formed.

- 13) *La fleur, vous les trouverez fletries

It follows from the observations that agreement has reflexes with respect to interpretation.

Investigating further the properties of (13), it might be assumed that all NP's receive an index under the Theory of Referential Indexing proposed in Chomsky (1980) and elsewhere. Ignoring for the moment the index of the subject, (13) could have either of the forms in (14).

14)a La fleur_i, vous les trouverez PRO_i fletries

b La fleur_i, vous les trouverez PRO_j fletries

Supposing that agreement indexing is identical to referential indexing, both (14)a and b must be ruled out along with (15).

15) Les fleurs_i, vous les trouverez PRO_i fletries

By hypothesis, the rule of predication which permits construal for such cases requires coindexing. Hence, (14)b and (15) are simply uninterpretable. The question, then, is what rules out (14)a.

Fiengo (p.c.) proposes to discard the indexing in (14)a with the constraint in (16).

16) An argument and a nonargument may bear identical referential indices iff they are an agreement pair
In (14)a, "la fleur" is in a nonargument position, TOPIC. It is coindexed with an argument position, PRO, which is the direct object of the verb. It follows from (16) that "la fleur" and "PRO" must be an agreement pair. By the definition of agreement pair given in Chapter III, the members of an agreement pair must be inflectionally identical. "La fleur" and PRO are not inflectionally identical and, hence, fail to be an agreement pair in contravention to (16). (14)a is ruled out as a consequence of (16).

Some adjustments to (16) are required unless the theory of agreement pairs is elsewhere revised. The reader will observe that (17) is also ruled out by (16).

17) Ces fleurs_i, vous les trouverez PRO_i fletries
Although "ces fleurs" and PRO are inflectionally identical they fail to be in the same case domain at any point in the derivation of (17). But two constituents may be an agreement pair if and only if they are in the same case domain; by definition, "ces fleurs" and PRO are not an agreement pair. (17) is ruled out by (16). The result is counterintuitive. (17) presumably underlies the grammatical (1)a. It is sufficient to weaken (16) to (18).

18) An argument and a nonargument may bear identical referential indices iff they are inflectionally identical

(18) will weed out (14)a as ill-formed but permit (17) as desired.

Observe that (18) and the notion of agreement pairs may still be theoretically related. In short, the inflectional identity clause of the agreement pair definition can be deduced from (18) if the definition given in Chapter III is revised to (19).

19) For any pair of constituents (δ, ϵ) such that δ, ϵ occur in $\sigma, \dots [\sigma \dots \delta \dots \epsilon \dots] \dots$, (δ, ϵ) is an agreement pair iff:

i) $\delta = [+N, -V]$

and ii) a σ is a case assigner and

- b there is no σ' such that σ' is a case assigner
and σ' dominates δ or ϵ but not both
and iii) ϵ is bound by δ

"Bound" is defined in (20).

20) δ binds ϵ iff:

- i) δ c-commands ϵ
and ii) δ is coindexed with ϵ

If a constituent is not bound, then it is free.

Reviewing briefly before examining in more detail my claim about the inflectional identity clause (deleted in (19), clause (ii) in (1), Chapter III), the reader will observe that the (a) and (b) subclauses of clause (ii) in (19) entail that (δ, ϵ) occur in the same case domain. Clause (19)i is identical to clause (1)i in Chapter III. Clause (19)iii represents the relevant revision of the definition.

The definition of binding has the consequence that an agreement pair must be coindexed. Given that $\mathcal{G} = [+N, -V]$ and that a subset of $[+N, -V]$ categories serve as arguments, viz., that subset of NP's which are assigned θ -roles, it is plausible to assume that δ might be restricted to arguments. What about ϵ ? Values of ϵ range over $[\pm N, \pm V]$. I assume that $[-N, +V]$ and $[+N, +V]$ never serve as arguments. $[+N, -V]$ and $[-N, -V]$ may serve as arguments but only under restricted conditions, say where they are NP and S respectively and occur in a position where they can be assigned a thematic role. Otherwise, $[+N, -V]$ and $[-N, -V]$ count as nonarguments, e.g., predicate nominals in the former case and specifiers and prepositions in the latter. Assume then that $[\pm N, \pm V]$

may be values of ϵ only when not assigned a Θ -role. Any category which is not assigned a Θ -role is a nonargument. It follows then that δ is an argument and ϵ is a nonargument in every agreement pair. By (18), coindexed arguments and nonarguments must be inflectionally identical. Hence, (18) and (19) together entail the inflectional identity clause in the original definition of agreement pair.

My assumption that agreement indexing is referential indexing has further theoretical implications. Government/Binding Theory provides a comprehensive theory of referential indexing. NP's or arguments are assigned arbitrary (alphabetic) indices. Naturally, not all distributions of indices are required or permitted in the description of natural languages under the interpretations of reference, coreference and disjoint reference associated with referential indexing. The Binding Conditions discussed in the last chapter and repeated here as (21) constrain possible patterns of indices.

- 21)a An anaphor is bound in its governing category
- b An pronominal is free in its governing category
- c An R-expression is free

"Bound" and "free" occur in (21) with the senses defined above. Observe for the moment that the BC's place restrictions on the distribution of referential indices with respect to classes of nominals. Traces and anaphors must be bound under (21). Under certain conditions, pronominals and PRO cannot be coindexed. And no referential NP (including proper names, definite and indefinite descriptions and variables) may be coindexed to any other argument.

Chomsky (1981) restricts the application of (21) to arguments. The line of reasoning follows. Observe, for instance, that the variables bound by Quantifier Raising as formalized in May (1977) are clearly c-commanded and coindexed in their governing categories on at least some occasions. Consider the sentence in (22)a with its associated LF, derived by QR, in (22)b.

22)a Every person is hungry

b [_S Every person_i [_S e_i is hungry]]

Take "e_i" in (22)b as an in relation to (21). "e_i" has [+NOM] case. Furthermore, "e_i" is \bar{A} -bound, i.e., bound by a constituent in a nonargument position. Hence, "e_i" is a variable under the definition in (23) and the contextual definitions of empty categories offered in Chomsky (1981).²

23) [_{NP} e] is a variable iff it has case

But inspection of "e_i" in (22)b shows that it is bound in the governing category S by the quantifier, "every person." But by (21)c, which counts variables as R-expressions, variables must be free. The dilemma is resolved by assuming that the Binding Conditions apply only to the relations of indices indexing arguments or A-binding relations. Hence, the indexing in (22)b does not violate the Binding Conditions.

It is precisely the restriction of the Binding Conditions argued for by Chomsky which permits the referential coindexing of "ces fleurs" and PRO in (17). By (21)b, PRO must be free in its governing category. No NP bracket intervenes between "ces fleurs" and PRO. I assume then that

the maximal S node dominating PRO is its governing category. TOP is dominated by the same maximal S node dominating PRO. "Ces fleurs" occurs in PRO's governing category. Because "ces fleurs" c-commands and is coindexed with PRO, it follows from my observations and (20) that PRO is bound in its governing category in contravention to (21). But the coindexing of TOP and PRO is permissible because TOP is a nonargument, the indices of which do not count for the Binding Conditions. For the purposes of the BC's, PRO is free as required.

I will formalize the result of distinguishing between arguments and nonarguments by assuming that values of δ in (20) are restricted to arguments. As a consequence of this stricture, no further stipulation on values of δ in (19) is required. By (19)iii, ϵ must be bound to δ in an agreement pair (δ, ϵ) . But δ can bind ϵ only if δ is an argument due to my restriction to (20). It might be argued that the syntactic restriction to [+N, -V] is required to exclude sentential subjects from agreement pairs. Recall that it was argued in Chapter III that the singular agreement of tensed verbs in matrix clauses with sentential subjects was not the result of agreement. Rather third person singular is simply the unmarked case for verbal inflection when there is no nominal source for number marking. Stowell (1981) observes that as a result of his Case Resistance Principle that sentences in subject position are forced to extrapose. A discussion of the categorial specification of the empty category left in [NP, S] is beyond the scope of my research

but it should be pointed out that it is an argument. Thus, the CRP does the work of excluding sentences from agreement pairs by forcing extraposition from a potential agreement source. The argument that remains need not be excluded at all. Hence, I conclude that the restriction to (20) is sufficient for my purposes and clause (i) of (19) can be dropped.

Although I have excluded nonarguments as values of δ in (20), it does not follow that they may be similarly excluded from values of ϵ . Nor does it follow that they may be excluded from the provisions of (21). That is, the restriction I have imposed on (20) voids the application of the Binding Conditions in cases like (22)b by assuming that nonarguments may not be binders for A-binding or the set of binding relations governed by (21).³ However, it does not follow that nonarguments are excluded from being the bindee of an argument under the Binding Conditions.

Consider again the case of (1)a. (24) provides an explicitly indexed underlying form for (1)a.

24) Ces fleurs_i, vous les trouverez PRO_i fletries_i
As I proposed previously, "ces fleurs" and PRO are coindexed as the output of a mechanism assigning referential indices to NP's. Assuming that referential indexing and the inflectional indexing that I previously supposed subject to Percolation are identical, Percolate α assigns the referential index of PRO to "fletries."

Since all of the indices in (24) are referential, they are subject to the Binding Conditions. Although PRO is c-commanded by and coindexed with "ces fleurs," "ces

fleurs" is not a value of δ in (20) and does not bind PRO. PRO is bound by no other argument. Therefore, PRO is free as required by the Binding Conditions. A similar line of deduction may be applied to the relation between "fletries" as binder and PRO as bindee. "Fletries" is a nonargument; hence, a nonbinder in (20) and again PRO is free. However, PRO is an argument and, thus, may serve as a binder for "fletries." In fact, if my definition of agreement pair is correct and PRO and "fletries" are an agreement pair, then "fletries" must be bound by PRO. Does the coindexing by which "fletries" is bound fall under the Binding Conditions?

The answer to the question depends on the properties of an agreeing constituent. Three characteristics of "fletries" are relevant. First, it is lexically realized. Second, it has case. And third, it contains pronominal features. Despite the pronominal features which it contains, "fletries" cannot be subsumed under (21)b of the Binding Conditions. By (21)b, pronominals or PRO must be free in their governing category. But "fletries" is, on any account of governing category with which I am familiar, bound to PRO in its governing category in contravention to (21)b. Since "fletries" has case, it must be a lexical anaphor or free in every governing category. By hypothesis, however, it is bound in some governing category. Therefore, the adjective must be a lexical anaphor. By (21)a, lexical anaphors must be bound in every governing category. Since "fletries" is bound to PRO in its governing category, it meets the proviso (21)a. I conclude that values of ϵ in (19) are lexical

anaphors.

In the theory I have proposed, it is easy to formalize the anaphoric status of agreeing elements. In Chapter II, I assumed the general lexical form of a number marker is (25).

25) [ϕ , [+]_{X^o___}]_{X^o, α NUM,...}], ...]

The result that one member of an agreement pair is anaphoric can be accounted for by distinguishing inflectional markers into two subcases, the one shown in (25) and the other in (26).

26) [ϕ , [+]_{X^o___}]_{X^o,+ANA(PHOR), α NUM}], ...]

In brief, (25) characterizes the lexical class of number markers for arguments. (26) gives the class of morphemes associated with nonarguments or agreement anaphors.

On the assumption that an agreeing constituent is a lexical anaphor, the effects of the Agreement Filter in Chapter I are immediately entailed and the less than optimal condition on Percolation, obligatoriness, proposed in Chapter III is removed. In Chapter III, had Percolation of inflectional features not been obligatory, forms like (27) would be derived.

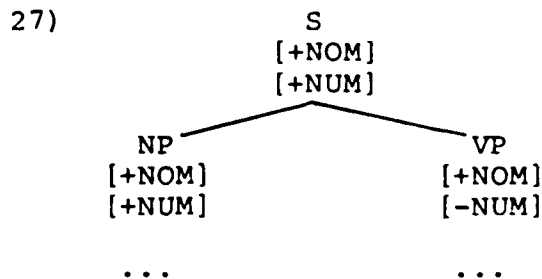

Obligatory Percolation results in the nodes dominated by VP being inflectionally marked for both [+NUM] and [-NUM].

(27) is ruled out by the conflict of number marking.

The assumption that the verb in (27) is marked as an anaphor by affixation of (26) as shown in (28) permits me to discard the less than optimal condition imposed on Percolation.

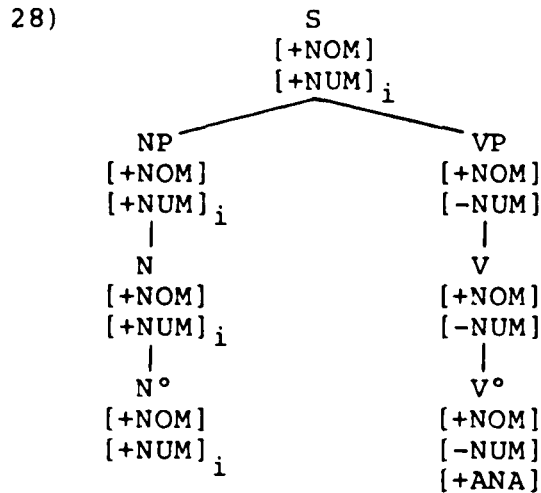

By the Binding Conditions, lexical anaphors like V° in (28) must be bound in their governing category. I assume that nonnominal nonarguments may obtain a referential index only by Percolation from some argument. Percolation has failed to apply into VP in (28). Thus, the lexical anaphor in (28) is free in its governing category and ruled out by the Binding Conditions. Suppose Percolation does apply. If only the referential index is Percolated, (28) is ruled out by (18). If the feature, [+NUM], plus the referential index is Percolated, (28) will contain nodes with conflicting number marking. Given the anaphoric status of the agreeing constituent in (28), there is no need to assume that Percolation is obligatory or further stipulate an Agreement Filter.

It will be useful to complete the thesis by reviewing in more detail the effects of the indexing proposal on the

the agreement phenomena I observed in the last chapter. So I will briefly consider its consequences for object/participle agreement, predicate agreement and specificational agreement in NP.

Take the case of object/participle agreement first. Assuming as I have that referential indexing and inflectional indexing are identical and that Percolation occurs prior to movement, the movement cases have the forms in (29).

- 29)a ... [COMP *wh*-NP_i] ... part+AGR_i x_i ...
b ... NP_i ... part+AGR_i e_i ...

In (29), agreement will be bound by either the trace of movement or the position to which movement occurs. Now consider the clitic case, (30).

- 30) ... CL_i ... part+AGR_i PRO_i ...

Again, the agreement anaphor may be bound either by PRO or the clitic. However, no further insight into the constraint that the agreement antecedent must be to the left is derived from my indexing hypothesis. On the whole, I don't see that the facts offer any difficulty for the hypothesis.

The same holds for the cases of predication that I have observed, at least in the case of predicate adjectives. Assuming as I have the raising hypothesis of copulars, predicate adjectivals will be indexed prior to movement and, as anaphors, bound either by the trace or by the surface subject. Difficulty is encountered with the examples like (31).

- 31) The women are a large group

On Williams' (1980) predication theory as well as my

Percolation hypothesis, (32) is expected.

32) The women_i are_i a large group_i

I assume indices may Percolate independently of their inflectional features. However, the indexing in (32) is ruled out by (18) since it involves an inflectionally distinct argument and nonargument. Note that it will not suffice here to say that (34) does not contain an agreement pair. (18) is, presumably, a more general condition from which some of the properties of agreement pairs follow. I am sorry to say that I remain puzzled at this result and only further investigation will lead to greater insight.

As it stands, the indexing system may be easily extended to agreement relations that do not involve agreement pairs in the technically restricted sense I have adopted. A case in point is the agreement properties of ~~specifiers~~. Suppose that specifiers may take as affixes forms such as (26). The structure underlying "these men" in the sentence "These men run" will be (33).

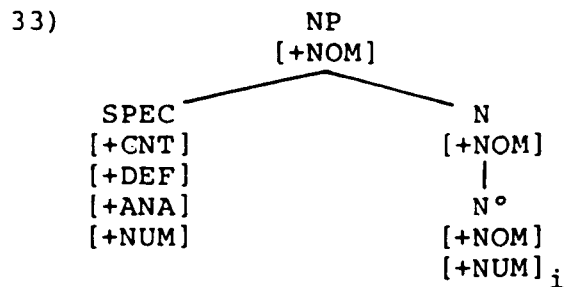

Assuming as I have that inflectional and other syntactic features may Percolate under the constraints imposed on subcategorization, indexing appropriate to the binding of the anaphor in (33) can be generated.

I believe it is fair to ask in the context of my

proposals what distinguishes (34)a from (34)b.

34)a John saw those_i friends_i

b *John saw each other's_i friends_i

*John saw their own_i friends_i

Under my assumptions about referential indexing, the subject slot of NP may receive indices either as a nominal or from Percolation into SPEC. However, the unacceptability of the examples in (34)b shows that subjects of NP may not be coindexed with the head of the NP. The facts follow from Chomsky's (1981) more general *i*-within-*i* Constraint or, as I will adopt, Williams' (ms.) NP_i/NP_i Constraint given in (35).

35) No NP may be coindexed with an NP it contains
(35) is sufficient to permit (34)a while ruling out (34)b. And in the last chapter it was seen that it further explains the distinction between possessive "pronominal" and full lexical NP subjects in French. Apparently, possessive subjects in French do not have the status of NP's for (35).

Also observe that the theory of agreement in the specifier cases may be further refined. Suppose, in fact, SPEC in English bears the features [+GNT] optionally. In French, however, SPEC is never [+GNT]. Thus, in English, SPEC has two options for obtaining case; it is inherent or it is dropped. When it is dropped SPEC of N° and N° will be in the same case domain and, hence, may count as an agreement pair. Suppose further, following Battistella (1981), that when a feature is dropped into a category, it drops only to the head of the category although it may

subsequently be Percolated elsewhere. Now assume that a feature complex, [σ CASE, α NUM, β PER, γ GEN], has a single index and that the Percolation of any feature is sufficient to carry that index. In light of these assumptions, consider the case of "John's book" where SPEC is not inherently [+GNT]. If Percolation does not occur, "John" will not bear case and the phrase will be ruled out by the Case Filter. If Percolation does occur, "John" will be coindexed with the head of the NP in contravention to (35). In French, where SPEC is never [+GNT], it follows that there is no way for an NP like "*Jean livre" to surface. On this account, notice that the agreement properties of specifiers can be subsumed under the definition of agreement pair I have proposed without further difficulty, while still providing an explanation of the difference between French and English with respect to possessive subjects of NP.

In conclusion, the assumption that agreeing constituents are lexical anaphors permits desirable results. First, it entails the Agreement Filter without any further stipulation to the rule of Percolation. Second, it permits an extension of the theory of referential indexing to non-arguments in a fashion consistent with Binding Theory. Finally, it permits the description of agreement to pairs to be generalized to (36).

- 36) For any pair of constituents (δ, ϵ) such that δ, ϵ occur in σ (... [$_{\sigma}$... δ ... ϵ ...] ...), (δ, ϵ) is an agreement pair iff:

i) δ is an argument

and ii) ϵ is an anaphor

and iii) a σ is a case assigner and

b there is no σ' such that σ' is a case

assigner and dominates δ or ϵ but not both

When the definition of agreement pairs given in (36) is embedded in a theory of grammar containing the independently justified conditions I have discussed, the properties of the distribution of grammatical number follow without further stipulation.

Footnotes

1. Results below will entail that the rule of predication involved is not identical to that investigated by Williams (1980).
2. Cf. Chomsky (1981).
3. Given the restrictions on the values of binders I elaborate, the notion of binding here is not analogous to that of Proper Binding in May (1977).

Bibliography

- Altham, J.E.J. (1971). *The Logic of Plurality*. London: Methuen and Company, Ltd.
- Aoun, J. (ms.). "On Government, Casemarking and Clitic Placement," unpublished MIT manuscript.
- Bach, E. and T. Harms, eds. (1968). *Universals in Linguistic Theory*. New York: Holt, Rinehart and Winston.
- Baltin, M. (1978). *Toward a Theory of Movement Rules*. Unpublished MIT Ph.D. dissertation.
- Bartsch, R. (1973). "The Semantics and Syntax of Number and Numbers," *Syntax and Semantics*. ed. J. Kimball, New York: New York: Seminar Press. 2:51-91.
- Battistella, E. (1981). *Topics in the Theory of Inflection*. Unpublished CUNY Ph.D. dissertation.
- Belletti, A. (1980). "On the Anaphoric Status of the Reciprocal Construction in Italian," mimeographed, MIT and Scuola Normale Superiore.
- Borer, H. (1979). "Empty Subjects and Constraints on Thematic Relations," paper presented at NELS X, Ottawa, mimeographed, MIT.
- _____ (1980). "On the Definition of Variables," mimeographed, MIT.
- _____ (1981). *Parametric Variation in Clitic Constructions*. Unpublished MIT Ph.D. thesis.
- Bresnan, J. (1978). "A Realistic Transformational Grammar," *Linguistic Theory and Psychological Reality*. eds. M. Halle, J. Bresnan and G. Miller, Cambridge: MIT Press.
- Carlson, G. (1977). "A Unified Analysis of the English Bare Plural," *Linguistics and Philosophy*, 1:413-453.
- Cartwright, H. (1965). "Heraclitus and the Bath Water," *Philosophical Review*, 74:467-485.
- _____ (1970). "Quantities," *Philosophical Review*, 79:25-42.
- _____ (1975). "Some Remarks about Mass Nouns and Plurality," *Synthese*, 31:395-410.
- Chomsky, N. (1965). *Aspects of a Theory of Syntax*. Cambridge: MIT Press.

- Chomsky, N. (1977a). *Essays on Form and Interpretation*. New York: Elsevier North-Holland.
- _____ (1977b). "On *wh*-Movement," *Formal Syntax*. eds. P. Culicover, T. Wasow and A. Akmajian.
- _____ (1979a). "On Markedness and Core Grammar," to appear in A. Belletti, L. Brandi and L. Rizzi, eds., *Theory of Markedness in Generative Grammar*, Proceedings of the 1979 GLOW Conference. Pisa: Scuola Normale Superiore.
- _____ (1979b). "Principles and Parameters in Syntactic Theory," mimeographed, MIT.
- _____ (1980a). "On Binding," *Linguistic Inquiry*, 11.2.
- _____ (1980b). "On the Representation of Form and Function," mimeographed, MIT.
- _____ (1981). *Lectures on Government and Binding*. Dordrecht: Foris Publications.
- Culicover, P., T. Wasow and A. Akmajian, eds., (1977). *Formal Syntax*. New York: Academic Press.
- Dougherty, R. (1968). *A Transformational Grammar of Coordinate Conjoined Structures*. Unpublished MIT Ph.D. dissertation.
- Edwards, J. (1980). "On Clitic Position in Romance," unpublished MIT ms.
- Elliott, W.N. (1980). "Plurality and Variable Binding," *Proceedings of the 16th Annual CLS Meeting*. Chicago: University of Chicago Press.
- _____ (ms.). "Inflection and Possession," mimeographed, MIT and CUNY.
- Emonds, J. (1976). *A Transformational Approach to English Syntax*. New York: Academic Press.
- Farmer, A. (1980). *On the Interaction of Morphology and Syntax*. Unpublished MIT Ph.D. dissertation.
- Fauconnier, G. (1979). *Theoretical Implications of Some Global Phenomena in Syntax*. New York: Garland Publishing, Inc.
- Fiengo, R. (1974). *Semantic Conditions on Surface Structure*. Unpublished MIT Ph.D. dissertation.
- _____ (1977). "On Trace Theory," *Linguistic Inquiry* 8.1.
- _____ (1980). *Surface Structure: The Interface of Autonomous Components*. Cambridge: Harvard University Press.

- Fiengo, R. and E. Battistella (to appear). "Inflection and Subcategorization," *Linguistic Inquiry*.
- Fiengo, R. and J. Higginbotham (to appear). "Opacity in NP." *Linguistic Analysis*.
- Frege, G. (1952). "On Concept and Object," in P. Geach and M. Black, eds., *Translations from the Philosophical Writings of Gottlob Frege*. Oxford: Basil Blackwell and Mott.
- _____ (1953). *The Foundations of Arithmetic*. Second ed., J.L. Austin, tr. Oxford: Basil Blackwell and Mott.
- Gleitman, L. (1969). "Coordinating Conjunctions in English," in *Modern Studies in English*, D. Reibel and S. Schane, eds.
- Grevisse, M. (1969). *Le Bon Usage*. Ninth ed. Paris: S.J. Ducolot, S.A.
- Hale, K. (1973). "Person Marking in Walbiri," in *A Festschrift for Morris Halle*, S. Anderson and P. Kiparsky, eds.
- _____ (ms.). "On the Position of Warlpiri in a Typology of the Base," mimeographed, MIT.
- Hale, K., L. Jeanne and P. Platero (1977). "Three Cases of Overgeneration," in P. Culicover, T. Wasow, and A. Akmajian, eds.
- Higginbotham, J. (1979). "Pronouns and Bound Variables," in E. Battistella, ed., *Proceedings of NELS IX*. New York: CUNYForum.
- _____ (1980). "Reciprocal Interpretation," mimeographed, MIT.
- Higginbotham, J. and R. May (1979). "Questions, Quantifiers and Crossing," mimeographed, Columbia and MIT.
- Hogg, R.M. (1977). *English Quantifier Systems*. Amsterdam: North-Holland Publishing Co.
- Hyams, N. (1980). "Thematic Constraints on Auxiliaries and Agreement in Italian," unpublished CUNY ms.
- Jackendoff, R. (1977). *\bar{X} -Syntax: A Study of Phrase Structure*. Cambridge: MIT Press.
- Jaeggli, O. (1980). *On Some Phonologically Null Elements in Syntax*. Unpublished MIT Ph.D. dissertation.
- _____ (1980a). "Remarks on to-Contraction," *Linguistic Inquiry* 11.1.

- Jespersen, O. (1964). *The Essentials of English Grammar*. University of Alabama Press.
- _____ (1965). *The Philosophy of Grammar*. New York: W.W. Norton and Co., Inc.
- Katz, J.J. (1972). *Semantic Theory*. New York: Harper and Row, Inc.
- _____ (1980). *Propositional Structure and Illocutionary Force: A Study of the Contribution of Sentence Meaning to Speech Acts*. Cambridge: Harvard University Press.
- Kayne, R. (1975). *French Syntax: The Transformational Cycle*. Cambridge: MIT Press.
- Kroch, A. (1974). *The Semantics of Scope in English*. Unpublished MIT Ph.D. dissertation.
- Lakoff, G. and S. Peters (1969). "Phrasal Conjunction and Symmetric Predicates," in *Modern Studies in English*, D. Reibel and S. Schane, eds.
- Langacker, R. (1968). "Observations on French Possessives," *Language* 44:51-75.
- Langendoen, D.T. (1977). "On the Logic of Reciprocity," *Linguistic Inquiry* 8:177-198.
- _____ (1980). "On Some Logical Properties of Covertly Binary Relations in Natural Languages," mimeographed, CUNY.
- Lapointe, S. (1979). *A Theory of Grammatical Agreement*. Unpublished U. of Massachusetts Ph.D. dissertation.
- Lieber, S. (1979). "Inflection and the Lexicon," mimeographed, MIT.
- _____ (1980). *On the Organization of the Lexicon*. Unpublished MIT Ph.D. dissertation.
- May, R. (1977). *The Grammar of Quantification*. Unpublished MIT Ph.D. dissertation.
- _____ (1981). "Movement and Binding," *Linguistic Inquiry*.
- McCawley, J. (1968). "The Role of Semantics in a Grammar," in E. Bach and R. Harms, eds.
- Milsark, G. (1977). "Toward an Explanation of Certain Peculiarities of the Existential Construction in English," *Linguistic Analysis* 3.1.

- Moravcsik, E. (1978). "Agreement," *Universals of Human Language*, Vol. IV, J. Greenberg, ed. Stanford: Stanford University Press.
- Patrick, R. (1970). *Referential and Nonreferential Noun Phrases*. Seattle: University of Washington Press.
- Pelletier, F. (1979). "Non-Singular Reference: Some Preliminaries," in F. Pelletier, ed.
_____ ed. (1979). *Mass Terms: Some Philosophical Problems*. Dordrecht: D. Reidel Publishing Co.
- Pesetsky, D. (1978). "Complementizer-trace Phenomena and the Nominative Island Condition," mimeographed, MIT.
- Price, G. (1971). *The French Language: Present and Past*. London: Edward Arnold.
- Quine, W. (1960). *Word and Object*. Cambridge: MIT Press.
- Reibel, D. and S. Schane, eds. (1969). *Modern Studies in English: Readings in Transformational Grammar*. Englewood Cliffs: Prentice-Hall, Inc.
- Riemsdijk, H. van (1980). "On Theories of Case: The Case of German Adjectives," mimeographed, MIT.
- Safir, K. (to appear). "Inflection-Government and Inversion," *Linguistic Review*.
_____ (ms.). "The ECP, θ -Criterion, and the Status of Null Expletive Elements," mimeographed, MIT.
- Sandfeld, K. (1970). *Les Pronoms*. Vol. I of *Syntaxe du Francais Contemporain*. Paris: Librairie Honore Champion, Editeur.
- Smith, C. (1969). "Ambiguous Sentences with *And*," in D. Reibel and S. Schane, eds.
- Stowell, T. (to appear). "Subjects Across Categories," *Linguistic Review*.
_____ (1978). "What There was Before There was There," mimeographed, MIT.
_____ (1981). *Origins of Phrasestructure*. Unpublished MIT Ph.D. dissertation.
- Taraldsen, K.T. (1978). "On the NIC, Vacuous Application and the *that*-trace Filter," mimeographed, MIT.

Vendler, Z. (1967). "Each and Every, Any and All," *Linguistics and Philosophy*. Ithaca: Cornell University Press.

Ware, R.X. (1979). "Some Bits and Pieces," in Pelletier, ed.

Williams, E. (1975). "Small Clauses in English," in *Syntax and Semantics*, Vol. 4, J. Kimball, ed. New York: Academic Press.

_____ (1980). "Predication," *Linguistic Inquiry* 11.1.

_____ (1981). "'Lexically Related' and 'Head of a Word,'" *Linguistic Inquiry* 12.2.

_____ (ms.). "The NP Cycle," mimeographed, U. of Massachusetts.

Zubizarreta, M.-L. (1980). "Remarks on Portuguese Infinitives," mimeographed, MIT.