

INFORMATION TO USERS

This reproduction was made from a copy of a document sent to us for microfilming. While the most advanced technology has been used to photograph and reproduce this document, the quality of the reproduction is heavily dependent upon the quality of the material submitted.

The following explanation of techniques is provided to help clarify markings or notations which may appear on this reproduction.

1. The sign or "target" for pages apparently lacking from the document photographed is "Missing Page(s)". If it was possible to obtain the missing page(s) or section, they are spliced into the film along with adjacent pages. This may have necessitated cutting through an image and duplicating adjacent pages to assure complete continuity.
2. When an image on the film is obliterated with a round black mark, it is an indication of either blurred copy because of movement during exposure, duplicate copy, or copyrighted materials that should not have been filmed. For blurred pages, a good image of the page can be found in the adjacent frame. If copyrighted materials were deleted, a target note will appear listing the pages in the adjacent frame.
3. When a map, drawing or chart, etc., is part of the material being photographed, a definite method of "sectioning" the material has been followed. It is customary to begin filming at the upper left hand corner of a large sheet and to continue from left to right in equal sections with small overlaps. If necessary, sectioning is continued again—beginning below the first row and continuing on until complete.
4. For illustrations that cannot be satisfactorily reproduced by xerographic means, photographic prints can be purchased at additional cost and inserted into your xerographic copy. These prints are available upon request from the Dissertations Customer Services Department.
5. Some pages in any document may have indistinct print. In all cases the best available copy has been filmed.

**University
Microfilms
International**

300 N. Zeeb Road
Ann Arbor, MI 48106

8501160

Moore, Denny

**SYNTAX OF THE LANGUAGE OF THE GAVIAO INDIANS OF RONDONIA,
BRAZIL**

City University of New York

Ph.D. 1984

**University
Microfilms
International** 300 N. Zeeb Road, Ann Arbor, MI 48106

**Copyright 1984
by
Moore, Denny
All Rights Reserved**

SYNTAX OF THE LANGUAGE OF THE GAVIÃO INDIANS OF RONDÔNIA, BRAZIL

by

DENNY MOORE

(DENNIS ALBERT MOORE)

A dissertation submitted to the Graduate Faculty
in Anthropology in partial fulfillment of the
requirements for the degree of Doctor of Philosophy,
The City University of New York.

1984

COPYRIGHT BY
DENNY MOORE
(DENNIS ALBERT MOORE)

© 1984

This manuscript has been read and accepted for the Graduate Faculty in Anthropology in satisfaction of the dissertation requirement for the degree of Doctor of Philosophy.

August 23, 1984
date

Sally Luchendo
Chairperson of Examining Committee

August 30, 1984
date

Sydel Silverman
Executive Officer

D. Terence Langendoen

Edward Bendix

Sally McLendon

Norman A. McQuown
Supervisory Committee

The City University of New York

Abstract

SYNTAX OF THE LANGUAGE OF THE GAVIÃO INDIANS OF RONDÔNIA, BRAZIL

by

Denny Moore

Adviser: Professor Sally McLendon

This is the first major description of the language of the Gavião Indians of eastern Rondônia, Brazil. The Zoró, the Cinta Larga, and (probably) the Aruá Indians also speak dialects of this language, which belongs to the Mondé family of the Tupi linguistic stock.

This study is primarily a syntactic description. The analysis is generative in spirit; formal phrase structure rules and transformational rules are motivated and presented. Appendixes provide informal phonological and morphological sketches and an analyzed text.

The noun phrase or person prefix subject of a Gavião clause immediately precedes an auxiliary stem, which indicates tense, aspect, mood, sentence structural type (copula/noncopula), and sentence functional type (e.g. imperative, nonassertative, postfactive, etc.). Any number of verb phrases and embedded clauses can occur in a clause. Their order can be scrambled with no change in meaning other than a loss or gain in prominence. Any predicate nominal, verb phrases, or embedded clauses occur after the auxiliary stem, but three preposing rules operate under certain conditions to front a predicate nominal (if any) and/or one verb phrase or embedded clause. These preposing

operations front WH words and discourse pronouns.

There are many particles which either occur at the beginning or at the end of a sentence. The occurrence possibilities of these particles are given, along with minor transformational rules involving them.

The three minimal syntactic units are person prefixes, elementary words, and elementary word stems. Elementary words fall into five classes: nouns, verbs, pronouns, demonstratives, and particles. Elementary word stems fall into four classes: noun stems, verb stems (transitive or cross-referencing), adjective stems, and auxiliary stems.

The Gavião system of complex words and complex word stems is highly developed. These complex units are constructed from the minimal syntactic units given above. Phrases are relatively simple in structure.

The phonological sketch presents both surface and systematic phonemes. Major phonological rules are briefly stated. Downstep is a notable feature of the tone/length system.

Gavião is a relatively isolating language. The morphological sketch describes affixation, compounding and the important stem formative processes.

PREFACE

Let me say some things which are not common knowledge.

First of all, the enlightened descriptive linguist should do his or her business in lowland South America these days. Hundreds of indigenous languages with unforeseen properties await the investigator in the fabled Amazon Basin. Indian cultures (including their linguistic aspects) are alive and functioning there.

While this may have been a hazardous area in which to work in the days of Lévi-Strauss and Nimuendajú, there is little danger now, given modern transportation and modern medicines. The common fieldwork diseases are almost all preventable or treatable, though a person must, of course, prepare in advance to cope with them. The non-Indian is awkward and inept for the first few months in an Indian village, but the process of adaptation works steadily to improve the ease of living and working.

As is well known, academic preparation tends to adversely affect personality development in North America. Living with Indians and with Latins (such as the warm and lively Brazilians) is a specific antidote for this professional malady. Argumentativeness, ethnocentricity, arrogance, self-disgust, myopia, and tired blood are all conditions which can be treated by going south to a fresh, natural, and flavorful world.

The second point to be made is that the rather celebrated 'plight' of tropical forest Indians in South America is at least in principle completely unnecessary. Indians prosper if effective measures are taken to secure their land, health, and autonomy. These measures are

reasonably simple, inexpensive, and in no way hinder the larger national society. If they are not taken the results are horrible: mass death from disease, dispossession, subjugation, and apathy. When this occurs it is due to a lack of the will or the competence to prevent it, not to cosmic fate or necessity. It is important to understand this since the defeatist notions so often become self-fulfilling prophecies.

During my stay with the Gavião Indians there were many positive things: the reserve was surveyed and marked, two land invasions were repulsed, medical care was good, nut and rubber industries were established, several people learned to read Portuguese, and indigenous religious practices reasserted themselves. The land and health measures depended largely, but not entirely, on non-Indians for their success. The other things depended mainly on Indian intelligence and creative energy, though ideas, information, and assistance from some non-Indians were very useful.

I have noticed, however, that the non-Indian often does not contribute to the concrete realization of such positive things but rather succumbs to the temptation to be a shirker, bystander, little emperor, commentator, social science theory monger, or henchman for a power prince. Several times I was pressed by the Gavião to provide a rational explanation for the peculiar fact that so many non-Indians become ve'añãvêc ('liars, false talkers') when speaking to or about Indians. This is more puzzling than overt transgressions such as land grabs.

Once I pointed out that the situation was the same in the United States, where one formulation of it was that 'the white man speaks

with a forked tongue'. The Gavião found it quite interesting that this was a general pattern. We discussed various specific instances of lying (or withholding information) by non-Indians. Many of these were for immediate personal gain, but there was also an overall function of keeping Indians unaware and dependent. The discussion was both humorous and sobering.

One of the reasons I like the Gavião so much is that they think about things a lot.

Acknowledgements

Two young Gavião men were my primary teachers/informants/analytic collaborators. Alberto Sebirop da Silva (Padāk) was about twenty-two years old at the time, and his brother, João Sebirop da Silva (Cipiábîit or Basapeé), was perhaps eighteen years old.

Not only was their work excellent, but they had a subtle way of pointing toward solutions. One miserable day, when I was in despair of ever hearing the pitch with my tone-deaf ears, I noticed Alberto dandle his hat in his lap, whistle qódaât sérék kōro ('my new hat'), and then smile slowly. We began using whistled comparisons and the tone phonetics were resolved. It was only several years later that I realized it was no coincidence that the solution to the problem had appeared when needed.

Three other men also worked with me on the language at times: Catarino Sebirop da Silva (Séèbîrôôp), about twenty-five years old, Chambete Barros (Sévabáã), about thirty-eight years old, and Maniquito Barros (Majikîit), about thirty-six years old. An Arara Indian, Joaquim (Civakîi), provided some Arara data. A famed Cinta Larga Indian,

Oita Matina, provided information on the Maavéèc Cinta Larga dialect.

The following people contributed to the texts: Cabeleira (Sérifit), Chiquito (Sorabáà), Chicochegou (Ciposégòòp or Vaañáabáà), Tuchaua (Cikqbí pōòp), Wilson Gavião of Serra Morena, Miguel (Tífigi), Rosa (Icía ââp), Bojá, Ester (Ódi ádáatkââp), Cecília (Babe sâjâ), and Raimunda, a Kabít Cinta Larga. (It is still sometimes considered impolite to address someone by his or her Gavião name. Names of the dead are not spoken.)

All of the Gavião were helpful in some way and they have my gratitude and affection.

The people of the New Tribes Mission were always kind and helpful: Horst and Annette Stute, Harold and Connie Davis, Donald Olson, Gerson de Souza Guimarães, and Reinaldo Oliveira. My linguistic work benefitted from many conversations with Horst Stute. He was the first person to use the term 'downstep' in describing Gavião tone and kindly showed me his analysis of the auxiliary system before I explored it myself. Our phonological analyses differ in several areas, and our grammatical analyses do not necessarily agree.

Evi de Paula e Souza and Arnazildo Silva-Lima of the Fundação Nacional do Índio were, consecutively, in charge of the Posto Indígena Lourdes during my stay. Both were very helpful and friendly. Aimoré Cunha da Silva, head of the Aripuanã Park, was also very helpful.

I thank the FUNAI in Brasília for authorizing my research among the Indians. Some personnel of the Departamento de Estudos e Pesquisas were particularly kindly: Delvair Melatti and two workers known to me only as Isa and Ana. Maria da Conceição Militão Rocha of the Sala de Documentação was of great assistance in locating useful documents.

This research was done with formal affiliation with the Ciências Sociais section of the Instituto de Ciências Humanas of the Universidade Federal de Brasília. At the time Roque Laraia was director of the Instituto de Ciências Humanas and Roberto Cardoso de Oliveira was director of the Ciências Sociais section. Ken Taylor and Alcida Ramos of the Program in Social Anthropology helped me out immensely on several occasions and have my everlasting gratitude.

David Price provided useful preliminary information on field conditions in Rondônia. Dan and Silêde Gross let me stay in their home when I was in Brasília and even looked after me when I was sick. Dan staved off disaster by transacting necessary official business while I was quite literally up a creek in Rondônia.

Aryon Rodrigues of the Universidade Estadual de Campinas, the foremost scholar of Tupian languages, provided the original inspiration for my linguistic research. His publications on the Tupian languages in Rondônia pointed up their importance and provided information necessary for selecting a research site.

Work on this dissertation was supported by the Syntax Research Center of the University of California at Santa Cruz from September, 1982 through December, 1982. I am very grateful to Jorge Hankamer and Geoffrey Pullum for this assistance and for their many illuminating comments and ideas.

I am indebted to my adviser, Sally McLendon, for her advice and assistance and especially for her encouragement to conduct field research. Terry Langendoen (the Prince of Light) and Edward Bendix contributed valuable comments on thesis drafts. Robert Vago's comments on the phonology were useful though they could not be squeezed into

Appendix A. Any blunders in the present work are, of course, of my own doing.

The Department of Anthropology of the Graduate School of the City University of New York and its executive officer, Sydel Silverman, must be thanked for their support. Research for the dissertation was supported in part by a research fellowship and a research assistantship from the City University of New York.

Field research was supported by a National Science Foundation Grant to Improve Doctoral Dissertation Research, SOC 74-21873. That assistance is gratefully acknowledged.

TABLE OF CONTENTS

ABSTRACT.....	iv
PREFACE.....	vi
Acknowledgements.....	viii
SYMBOLS AND ABBREVIATIONS.....	xviii
Sections	
1.0 INTRODUCTION.....	1
1.1 The Gavião Indians.....	1
1.2 Linguistic Studies of Gavião and Related Languages.....	7
1.3 The Present Study.....	9
2.0 OVERVIEW: SENTENCES, MATRIX S ELEMENTS, SENTENCE FUNCTIONAL TYPES, AND SENTENCE STRUCTURAL TYPES.....	15
2.1 Matrix and Embedded Sentences, S and S'.....	15
2.2 Matrix S Elements.....	16
2.3 Sentence Functional Types.....	18
2.4 Sentence Structural Types.....	21
3.0 OVERVIEW: WORDS, WORD STEMS, PERSON PREFIXES, AND PHRASES.....	24
3.1 Elementary Words.....	24
3.2 Elementary Word Stems.....	27
3.3 Person Prefixes.....	29
3.4 Complex Words and Complex Word Stems.....	32
3.5 Verb Phrases, Verbs, and Verb Stems.....	33
3.6 Noun Phrases, Nouns, Noun Stems, Demonstratives, and Adjective Stems.....	34
3.7 Auxiliary Stems.....	36
3.8 Particles.....	38

4.0	NONCOPULA S' COMPOSITION.....	39
4.1	Multiple, Independent VPs, S's, and S'- <u>ás</u>	39
4.2	Noncopula S' Composition Rule.....	44
4.3	VP, S', and S'- <u>á</u> Preposing within S'.....	46
5.0	COPULA S' COMPOSITION.....	54
5.1	Copula S' Composition Rule.....	56
5.2	Auxiliary Stems in Copula Sentences.....	57
5.3	Predicate NP Preposing within S'.....	59
6.0	SENTENCE FUNCTIONAL TYPES, AUXILIARY STEM FEATURES, AND CLAUSES.....	63
6.1	Features and Values.....	66
6.2	Auxiliary Stem Segments and Auxiliary Stem Features.....	69
6.3	Sentence Functional Types.....	73
6.3.1	Assertative Clauses and Auxiliary Stems.....	73
6.3.2	Nonassertative Clauses and Auxiliary Stems.....	75
6.3.3	Imperative Clauses and Auxiliary Stems.....	77
6.3.4	Prohibitive Clauses and Auxiliary Stems.....	78
6.3.5	Exhortative Clauses and Auxiliary Stems.....	79
6.3.6	'Let' Clauses and Auxiliary Stems.....	80
6.3.7	Preventative Clauses and Auxiliary Stems.....	82
6.3.8	Desiderative Clauses and Auxiliary Stems.....	83
6.3.9	Simulfactive Clauses and Auxiliary Stems.....	84
6.3.10	Postfactive Clauses and Auxiliary Stems.....	85
6.3.11	Nominal Clauses and Auxiliary Stems, Relative Clause and Sentence Complement Equivalents.....	86
6.4	Coreferential Anaphora Within and Across Clause Boundaries.....	90
6.5	Rules for Auxiliary Stem Features.....	93

7.0	MATRIX S ELEMENTS, WH ELEMENTS, DISCOURSE PRONOUNS, PRE-S, AND POST-S.....	99
7.1	Pre-S M.S.E.s: Phrase Structure Rules and Syntactic Features.....	99
7.2	Demonstrative Phrases.....	104
7.3	Questions and WH Elements.....	105
7.3.1	Polar Questions, Nonassertative <u>té</u> , and WH Questions.....	105
7.3.2	WH Insertion.....	114
7.4	Discourse Pronouns.....	115
7.5	Preposing Transformations.....	116
7.6	Minor Transformations Involving Pre-S M.S.E.s.....	123
7.6.1	Scope Marker Placement.....	123
7.6.2	Third Person Singular Subject Insertion and Topicalization Particle Attachment.....	125
7.7	Post-S Composition.....	128
7.8	Minor Transformations Involving the Post-S M.S.E.s.....	134
8.0	SUMMARY OF RULES.....	137
8.1	Phrase Structure Rules.....	137
8.2	Insertions.....	137
8.3	Transformational Rules.....	138
8.4	Phonosyntactic Rules.....	139
9.0	NOUN PHRASES.....	140
9.1	Qualification Particles.....	140
9.2	Demonstratives.....	141
9.3	NP's.....	143
9.3.1	Adjective Stems.....	143
9.3.2	NP's Which Are Possessed NP' Stems.....	146
9.3.3	NP's Containing No Possessor.....	152

9.3.4	Pronouns.....	154
9.4	Appositions.....	156
9.5	Summary of NP Rules.....	157
10.0	VERB PHRASES.....	158
10.1	Qualification Particles in Verb Phrases.....	159
10.2	Transitive Verb Phrases.....	162
10.3	Cross-referencing Verb Phrases.....	165
10.4	Verb Phrases Composed of a Verb.....	168
10.5	Summary of Verb Phrase Rules.....	172
11.0	CONJUNCTION.....	173
11.1	Conjunction of VPs.....	173
11.2	Conjunction of NPs.....	174
12.0	COMPLEX WORDS AND COMPLEX WORD STEMS.....	176
12.1	Phonological Words.....	177
12.1.1	Juncture Type: Evidence from Segmental Sandhi and Boundness.....	178
12.1.2	Juncture Type: Evidence from Length Sandhi.....	179
12.2	Complex Words Derived from Phrases, Clauses, or Quotes.....	181
12.2.1	Complex Nouns Derived with <u>mát</u> and <u>méne</u>	181
12.2.2	Complex Verbs Derived with <u>ná</u>	183
12.2.3	Complex Say/Think Verbs Derived with <u>-á</u>	184
12.3	Complex Words and Complex Word Stems Derived from Elementary Words and Word Stems or from Complex Words.....	188
12.3.1	Complex Adjective Stems Derived with <u>déè</u>	188
12.3.2	Complex Verbs and Complex Verb Stems Derived with <u>ma-téé</u>	190
12.3.3	Complex Verbs and Complex Verb Stems Derived with <u>tígí</u>	191

12.3.4	Time and Place Constructions Derived with <u>tīgi</u>	195
12.3.5	The Problematical Particle <u>pāt</u>	199
12.4	Compound Complex Words and Word Stems.....	200
12.4.1	Compound Complex Nouns and Noun Stems.....	200
12.4.2	Measure and Indefinite Constructions.....	212
12.4.3	Compound Complex Adjective Stems.....	216
12.4.4	Compound Complex Verb Stems.....	217
12.4.4.1	NP' Stem Incorporation.....	217
12.4.4.2	Adjective Stem Incorporation.....	219
12.5	Summary of Phrase Structure Rules for Complex Words and Complex Word Stems.....	220
APPENDIX A: PHONOLOGY.....		223
1.0	The Orthography.....	223
1.1	Orthographic Symbol Inventory.....	223
1.2	Stops and Corresponding Nasals.....	224
1.3	Dental Affricates.....	224
1.4	Palatals.....	224
1.5	Fricative.....	226
1.6	Liquids.....	226
1.7	Vowels.....	226
1.8	Tone and Length.....	227
2.0	Systematic Phonology.....	228
2.1	Inventory of Consonants and Vowels.....	228
2.2	Nasalization.....	229
2.3	Consonant Rules.....	230
2.4	Systematic Tone Phonemes.....	231

2.5 Tone Rules.....	231
APPENDIX B: MORPHOLOGY.....	233
1.0 Person Prefixation.....	233
2.0 Nouns and Noun Stems.....	236
3.0 Adjective Stems.....	237
4.0 Transitive Verb Stems.....	238
5.0 Cross-referencing Verb Stems.....	239
6.0 Verbs.....	240
7.0 Diminutives.....	241
APPENDIX C: AN ANALYZED TEXT.....	243
REFERENCES CITED.....	271

SYMBOLS AND ABBREVIATIONS

Category Symbols:

Adj st	complex adjective stem
Adj'st	elementary adjective stem
Aux'st	auxiliary stem
Dem	demonstrative
DemP	demonstrative phrase
M.S.E.	matrix S element (mostly particles)
N	complex noun
N'	elementary noun
N st	complex noun stem
N'st	elementary noun stem
NP	noun phrase
NP'	noun phrase prime (nonpossessable NP head plus any following adjective stems)
NP'st	noun phrase prime stem (possessable NP head plus any following adjective stems)
Post-S	node dominating M.S.E.s at the end of S
Ppfx	person prefix
Ppfx.c	cross-referencing/coreferential person prefix (distinguished from Ppfx in certain subsections)
Pre-S	node dominating M.S.E.s at the front of S
Pro	pronoun
Prt	particle
Prt.q	qualification particle
S (plural: Ss)	maximal sentence, potentially containing M.S.E.s
S' (plural: S's)	clause contained in S
S- <u>ā</u> (plural: S'- <u>ās</u>)	a S' clause marked with the syntactic marker <u>-ā</u>

sfx	suffix
V	complex verb
V'	elementary verb
V st	complex verb stem
V st.c	complex cross-referencing verb stem
V st.t	complex transitive verb stem
V'st	elementary verb stem
V'st.c	elementary cross-referencing verb stem
V'st.t	elementary transitive verb stem

Formal Rule Symbols:

$X \rightarrow Y$	Rewrite X as Y.
$X \rightarrow (Z)$	Rewrite X as nothing or as Z.
$X \rightarrow Z^*$	Rewrite X as nothing or as any number of Zs.
$X \rightarrow Z^1$	Rewrite X as one or more Zs.
$X \rightarrow \left\{ \begin{array}{l} Y \\ Z \end{array} \right\}$	Rewrite X as Y or as Z.
$X \rightarrow \{Y, Z\}$	Rewrite X as Y or as Z (same as the above).
$X \rightarrow \{Y, Z\}^*$	Rewrite X as zero or more Ys and zero or more Zs, in any order.
$X \rightarrow \begin{array}{l} Y \\ \alpha Z \end{array} \quad \begin{array}{l} Y \\ \alpha Z \end{array}$	Rewrite X with the value $\underline{\alpha}$ for feature Z as Y with the value $\underline{\alpha}$ for feature Z.
$X \rightarrow \begin{array}{l} \langle a \rangle Z \\ \langle b \rangle Z \end{array} \quad \begin{array}{l} Y \\ \langle j \rangle Z \\ \langle k \rangle Z \end{array}$	Rewrite X with the value \underline{a} for feature Z as Y with the value \underline{j} for feature Z. Rewrite X with the value \underline{b} for feature Z as Y with the value \underline{k} for feature Z.

Syntactic Features and their Glosses:

Syntactic features are written all in upper case. Their values are written in lower case. When the values are referred to in the

text they are underlined. Values may be simply plus (p), negative (n), or unmarked (u), or they may be descriptive (e.g. imp 'imperative').

Auxiliary stem features and their values are given below:

	Features:	Values:
Tense:	PST 'past'	<u>p</u> , <u>n</u> , <u>u</u>
Aspect:	DEF 'definite'	<u>p</u> , <u>n</u> , <u>u</u>
	DUR 'durative'	<u>p</u> , <u>n</u> , <u>u</u>
Sentence Structural Type:	COP 'copula'	<u>p</u> , <u>n</u> , <u>u</u>
Mood:	SJV 'subjective'	<u>p</u> , <u>n</u>
Motion:	MOT 'motion'	<u>go</u> 'go'
		<u>come</u> 'come'
		<u>u</u> 'unmarked'
Sentence Functional Type:	S.F.TY	<u>asr</u> 'assertative'
		<u>nasr</u> 'nonassertative'
		<u>imp</u> 'imperative'
		<u>proh</u> 'prohibitive'
		<u>exh</u> 'exhortative'
		<u>let</u> 'let'
		<u>prev</u> 'preventative'
		<u>des</u> 'desiderative'
		<u>sim</u> 'simulfactive'
<u>psf</u> 'postfactive'		
		<u>nom</u> 'nominal'

It is cumbersome and unnecessary to indicate all of the auxiliary stem features and their values in the glosses. So features which have descriptive values are not indicated; only their values are given (e.g. des instead of desS.F.TY). In auxiliary stem glosses only the sentence functional type of the auxiliary stem is always indicated. For other features one or more values are considered usual or predictable and are not ordinarily indicated in the gloss. Those not indicated are:

Tense: uPST or nPST

Aspect: uDEF occurring with uDUR or with nDUR

uDUR occurring with uDEF

nDUR occurring with pDEF

(That is, absence of any aspect gloss implies uDEF, uDUR; nDUR implies nDUR, uDEF; and pDEF implies pDEF, nDUR.)

Sentence Structural Type: nCOP

Motion: uMOT

Other Syntactic Features:

ALN 'alienably possessed'

ARG 'takes preceding immediate constituent as its argument'

CTRL 'control'

EVENT 'event' (a feature of nouns and noun stems)

FIN 'finite' (contains an Aux stem)

INAL 'inalienably possessed'

MA 'accepts the prefix má-'

MOD	'modified by preceding immediate constituent'
PROX	'indicates proximity' (a feature of demonstratives)
SB	'substantive'
S.I.	'sentence initial'

Transcription and Glosses:

Examples in Gavião, illustrations, tables, and rules each are assigned a number in parentheses. The digit or digits preceding the decimal point indicate the section in which the illustrative material or rule appears. In the case of Gavião examples, the letter 'T' appears after the parentheses if the example is from a text; the letter 'A' appears if the example is approved by one or more informants. Gavião examples in the text are underlined; those which are numbered are not. Sometimes the base forms of morphemes are indicated with double slashes, especially if there is irregular allomorphy, e.g. //yá//, an auxiliary stem morph.

The orthography is explained in Appendix A. Hyphens are used to roughly indicate morpheme boundaries in Gavião examples. The very common stem formative morphemes are not segmented with hyphens, however. For example, the reduplicated stem formative vowel in ígi 'remove' is not separated from the root (base form //ík//). A double hyphen indicates an open internal juncture as well as a morpheme boundary. When a glottal stop occurs as the phonetic manifestation of open internal juncture it is placed between the hyphens, e.g. e-'-ígi 'remove you'. Hyphens can only roughly indicate boundaries because tones, fused vowels, and voicing cannot be segmented. There is no harm in this since the exact form of morphemes is never at issue and

the pronunciation of the whole word is preserved. Example:

Base Form: //yá-eé-na// 'past nondefinite nonassertative
auxiliary stem - that - like'

Surface Form: jéena

Hyphenated Orthography: jé-e-na

Gloss: pPST+nDEF+uDUR+nasr-th-lk

Each Gavião segment between hyphens has a corresponding gloss, and the glosses are separated by hyphens also, producing a one-to-one correspondence. Occasionally two Gavião morphemes form one segment. Then the glosses of the two morphemes are joined with a plus (+) to preserve the one-to-one correspondence of hyphenated segments and glosses. Example where a rising short tone indicates 'my':

zâp
1s+house 'my house'

When two English words are used to gloss one Gavião morpheme they are joined by a plus:

ma'ã
look+for 'look for'

A period is used instead of a plus in the case of abbreviations:

kí-nap
ev-ndef.tm 'indefinite time of evidence'

When two pieces of form (morphs) can be distinguished but only the combination has glossable meaning, not the parts, then the parts are joined by a plus and the combination receives one gloss, e.g.

des below:

jã-r+ava
nPST+nDUR-des 'nonpast nondurative desiderative Aux stem'

The gloss for a morpheme which has no overt expression is placed in parentheses:

pãñã
(3s)-tickle 'tickle him'

When structural detail in tree diagrams is irrelevant it is not shown. Triangles indicate this:

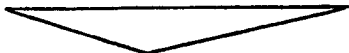
<u>qô-bi</u> 1s-face	<u>pogô-p</u> cover-nz	<u>sérék</u> cloth	'my blanket'
			
NP			

Glosses are only approximate. Auxiliary stems are glossed only by their features rather than by their translation in context as 'is', 'do', 'say', 'think', 'there is', etc. Verbs or verb stems which, very strictly, mean, e.g. 'be easy', 'be at', 'be in today', are glossed more simply as 'easy', 'at', 'today'. Initial demonstrative phrases can translate as time or as place. Quotes and thoughts in Gavião are marked with quotation marks ("), but these may translate as indirect quotes or thoughts. Many myth text sentences are formally sentence fragments: quotes followed by a time-of-evidence particle. The word té-teé is glossed as 'only' since the morpheme-by-morpheme gloss, 'exact-continuing', is unenlightening. Likewise, the word ma-téé is glossed as 'cause' instead of 'transitivization-flow'.

Person Prefix Gloss Abbreviations:

1s first person singular

2s	second person singular
3s	third person singular, noncoreferential
3c	third person cross-referencing (on cross-referencing verb stems) third person coreferential (on transitive verb stems, noun stems, and auxiliary stems)
1pi	first person plural inclusive
1pe	first person plural exclusive
2p	second person plural
3p	third person plural

Morphological Gloss Abbreviations:

dm	diminutive
intr	intransitivizing prefix
lk	'like', manner suffix
nz	nominalizing suffix
pl.o	plural object
pl.s	plural subject
pl.X	plural times or plural action
poss	prefix forming possessable noun stem
sg.o	singular object
sg.s	singular subject
sg.X	singular times or singular action
th-lk	'like that', common suffix and verb
tr	transitivizing prefix
w	prefix which derives words from word stems

Shape Noun Gloss Abbreviations:

ft.o	fruit-like object
holw.o	hollow object

hr.o	hair-like object
lf.o	leaf-like object
liq	liquid
l.t.o	long, thin object
s.r.o	small, round object

Particle Gloss Abbreviations:

adrs	address
adrse	addressee
aff	affirmative
conj	conjunction
cont	continuing
ev-ndef.tm	indefinite time of evidence
ev-prox.tm	proximate time of evidence
ev-rc1	recalled evidence
ev-rm.pst	remote past time of evidence
exct	exact(ly)
explan	explanation
fut	future
ints	intensification
nasr	nonassertative
nasr.tz	nonassertative topicalization
neg	negation
nsb.nz	nonsubstantive nominalization
pl	plural
pl.adrse	plural addressees
poss	possession dummy noun

prox.tm	proximate time
pst.prt	past participle
Q	question
rm.pst	remote past
sbs.nz	substantive nominalization
sg.adrse	singular addressee
s.m	syntactic boundary marker
tz	topicalization
vz	verbalization

1.0 INTRODUCTION

1.1 The Gavião Indians

The Gavião identify themselves as 'hawks', (singular: Ikólô, plural: Ikólêéc). Harald Schultz (1955) refers to them as the 'Digüt', but this is merely a personal name of one of the Gavião. Likewise his term for the Arara Indians, 'Urukú', appears to have no valid basis.

The Gavião live on the Posto Indígena Lourdes in several settlements near the Igarapé Lourdes, a stream which flows westward into the Ji-Paraná (or Machado) River. The Arara live about five hours walk to the south on the same reserve. The P.I. Lourdes is approximately sixty-five kilometers from the nearest town, Ji-Paraná (formerly Vila de Rondônia). The area of the reserve in eastern Rondônia (see Maps 1 and 2) is dense tropical forest with low mountains.

There were 144 Gavião at the end of 1977, half of whom were below the age of fourteen. There were 77 Arara. The population was growing at a rate of five percent per year. There were 188 Gavião in 1983 (Mello Leonel 1983: 84), including a few women from other tribes (but excluding all Zoró). The Arara numbered 92 in 1983 (Mindlin 1983: 124). Some Zoró also live on the P.I. Lourdes. The total Zoró population was about 190 and increasing in 1982.

The Gavião and Zoró Indians migrated westward together sometime early in this century because of military pressure from neighboring Indians, probably the Cinta Larga. They entered into peaceful contact with the Arara Indians, who occupied the territory between the Ji-Paraná River and the Rio Branco (a major river between the Ji-Paraná and



Map 1. Location of the Gavião Indians (X).
Adapted from Cultural Survival, Inc. 1981:32

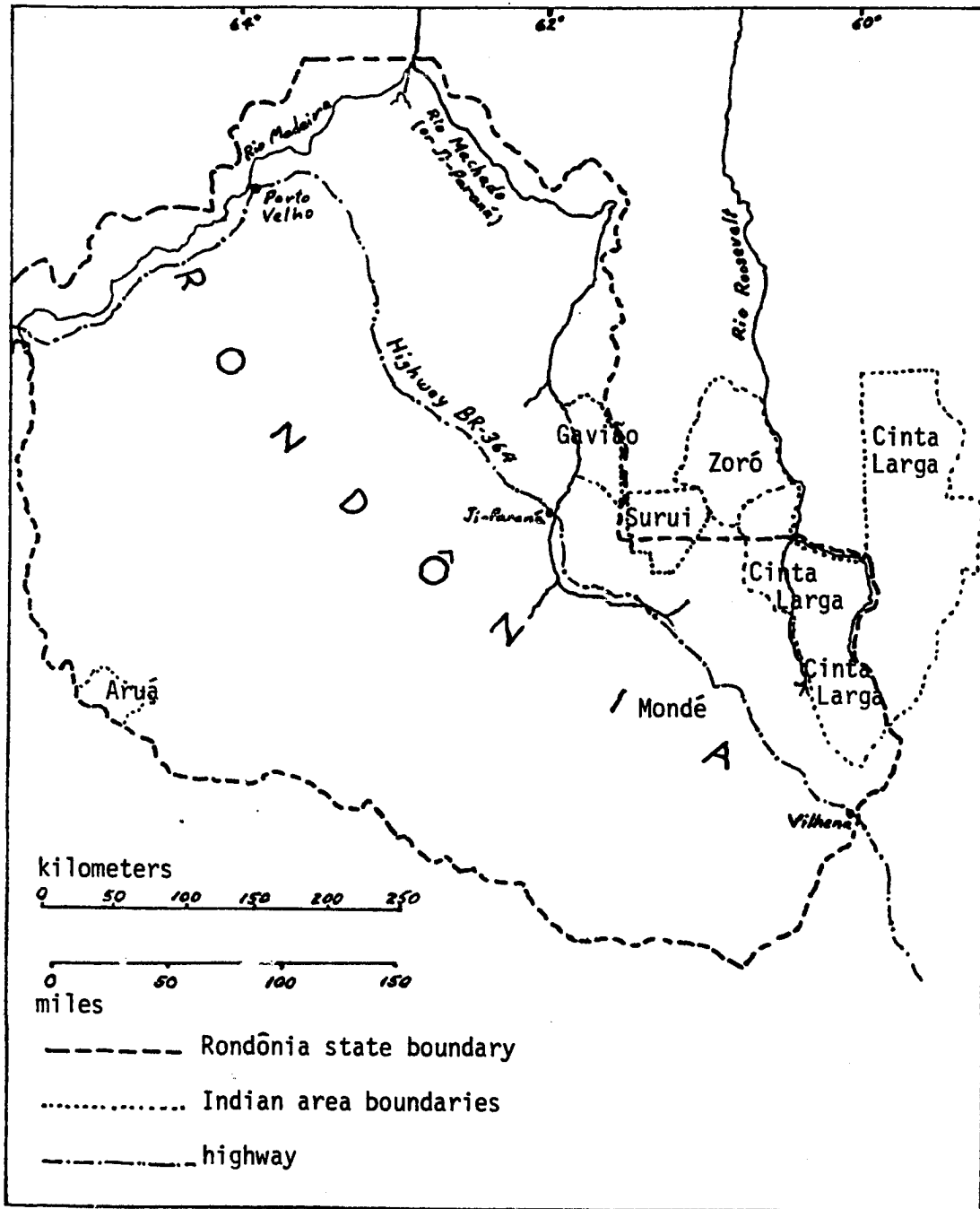

Map 2. Location of Indian groups speaking languages of the Mondé family. Adapted from Cultural Survival, Inc. 1981:32.

Roosevelt Rivers). Shortly before World War II there were four malocas (big houses) of Gavião near the Rio Branco and four malocas of Zoró a bit farther downstream.

The World War II demand for rubber brought non-Indians into the area. The Arara were contacted first, but the Gavião and Zoró also made trips to the Ji-Paraná River for trade goods. Shortly after the war a feud caused the Zoró to move to the east side of the Rio Branco and the Gavião to move westward into closer association with the Arara. The Gavião attacked the Arara in 1959, killing some and driving the others into contact with Brazilian society. The Arara contracted measles, and the survivors became debt peons on a rubber plantation. Many Gavião died from pneumonia complications of colds and influenza.

When an Indian agent and some New Tribes missionaries arrived in 1966 there were fewer than 100 Gavião and 50 Arara. After the arrival of these new protectors the Arara returned to the reserve and the population of both groups began to rebound.

The Gavião, like other Indian groups in the area, are primarily slash-and-burn horticulturalists and hunters. They sometimes fish in the streams, but seldom in the large rivers. In the dry season (June through September) they fish with bow and arrow and also poison fish with timbó. Gavião dugout canoes are small and simple.

The question of the original point of dispersal and the subsequent migration routes of Proto-Tupi speakers is recognized as a central issue in the prehistory of indigenous South America (Lathrap 1970, Meggers 1975). Sometimes it is assumed that migrations followed major rivers, but in eastern Rondônia known migrations have been

overland and settlements have been on smaller streams.

The Gavião grew sweet manioc but not bitter manioc before contact. Maize was an important food source. Sweet potatoes, cará, scarlet runner beans, peanuts, cotton, gourds, and tobacco were also grown. Some Gavião claim they got bananas, sugar cane, pineapples, and papaya from the Arara, though this hasn't been verified.

Kinship investigations among the Gavião are complicated by their post-mortem name taboo and by their recognition of copaternity. According to informants, a man may marry his classificatory sister's daughter (first person singular: ôbarápit) or his classificatory father's sister (bojá). Gavião men have a close, joking relationship with mother's brother (first person singular: zêrat), who is often a potential father-in-law. They respect father's brother (called papá 'father'). A man begins working for his prospective father-in-law as soon as he is engaged. The married couple resides with the wife's family, though it's not clear how permanent this is. Most men are monogamous, though traditionally a man might have two wives if they were sisters or if one had no living father. The status of women is generally very good.

A traditional maloca was founded by a respected man and contained his unmarried children, his married daughters, their husbands, and whichever other relatives opted to live there. The head of the house was referred to as zavijaãc ('house-owner'). Malocas are no longer built, but houses containing nuclear families still tend to cluster into groups, each informally headed by an influential man.

In 1977 there was one Gavião shaman still practicing. Indigenous religious notions show Christian influence after years of missionary

activity. Sometimes the Gorá spirits are equated with the Christian God and the Zagapôôc spirits, who assist the shaman, are equated with the devil. The Goñát ('thunder') spirits, associated with maize, and the nefarious Zerebaãc spirits seem to have no Christian equivalents. The Gavião learned to call the Olicicía spirits from the Arara. These usually speak Arara when they appear (in the dark), as I was able to confirm by observation.

The cultures of the Indians of eastern Rondônia have not been studied in depth until recently. Lévi-Strauss and Wanda Hanke did (independently) encounter the Mondé Indians, speakers of a sister language to Gavião. Both (independently) were struck by the charm and intelligence of the Mondé (Lévi-Strauss 1967: 327, Hanke 1950: 216). (Interestingly, the Gavião, Zoró, and Cinta Larga Indians are noted for this same peculiar charm and cleverness, in spite of their formidable reputation as warriors.)

Recently (1979-81) the Gavião and Zoró have been intensively studied by two Norwegian anthropologists from the University of Oslo, Lars Løvold and Elizabeth Forseth. Dr. Carmen Junqueira of the Pontifícia Universidade Católica de São Paulo has visited the Cinta Larga regularly since 1979.

The situation of the Gavião in 1977 was very good (Moore 1981): their reserve was demarcated, the mortality rate was very low in spite of a high incidence of malaria and some tuberculosis, native festivals were again being held, and the Indians earned what cash they needed through their own Brazil nut and rubber industries. People generally did as they pleased and organized their own activities.

In 1978 the Zoró Indians, recently recontacted, came to live with the Gavião for a couple of years. This was fortunate because the Gavião, the New Tribes missionaries, and the P.I. Lourdes personnel all assisted the Zoró, and--a relative success story--most of the usual postcontact depopulation and misery was averted.

The Polonoroeste development project is currently accelerating the pace of non-Indian settlement in Rondônia. The P.I. Lourdes received considerable attention and resources as a part of the Polonoroeste project area, but the effects of this were not very favorable to the Indians. The Gavião were required to work as laborers on large agricultural projects on their reserve. According to Mello Leonel (1983) those projects were unsuccessful. The Gavião now earn what cash they need by tapping rubber on an individual basis. The New Tribes Mission was expelled from the reserve in 1981. There are now two practicing shamans and some novices.

A road passing near the Gavião and Arara land has brought in non-Indian settlers. The predictable incursions were ignored for some time, and in 1983 there were about 350 invaders occupying the southeast corner of the reserve. It will now require a very serious effort to remove these people from Indian land.

1.2 Linguistic Studies of Gavião and Related Languages

A detailed classification of the languages of the Tupi linguistic stock has been presented by Rodrigues (1958 and 1962). This was slightly amended later to give Mundurucu status as a separate family. The newer classification (Rodrigues 1974: 53) divides the Tupi linguistic stock into eight linguistic families: (1) Tupí-Guaraní, (2)

Munduruku, (3) Juruna, (4) Arikém, (5) Tupari, (6) Ramarama, (7) Mondé, and (8) Puruborá. The last five of these are spoken in Rondônia.

Until recently there had been intensive studies of languages of the Tupí-Guaraní family (Firestone 1965, Gregores and Suárez 1967, Bendor-Samuel 1971 and 1972, and Harrison 1975) and of the Munduruku family (Crofts 1973), but the Tupian languages of Rondônia were known only through wordlists. This situation has been improved by the Summer Institute of Linguistics. Landin (1980) has studied the Karitiana language of the Arikém family and Bontkes (1978) has worked for years with the Surui language of the Mondé family. Clive Sandberg worked for several years with the Cinta Larga Indians of the P.I. Roosevelt, and was, I think, the first person to conclude that the language was tonal. Horst Stute of the New Tribes Mission has worked since about 1967 on the Gavião language, though he has not published his many manuscripts.

The current locations of Indian groups speaking languages of the Mondé family are shown in Map 2. According to Mindlin and Junqueira (1983) there are about 300 Surui and probably 500 or more Cinta Larga Indians. The population of the Surui is increasing, but no effort has been made to vaccinate the Cinta Larga who do not live on FUNAI (Fundação Nacional do Índio, the Brazilian Indian agency) posts, and many of these are dying. There are some Aruá Indians living on the P.I. Guaporé. This is their location as shown in Map 2, but they appear to have previously lived considerably to the east on the headwaters of the Rio Branco (tributary of the Guaporé River in southern Rondônia, not the Rio Branco east of the Ji-Paraná River). There are perhaps

a dozen families of Mondé Indians in the general vicinity of Pimenta Bueno in Rondônia.

It appears to me that there are three languages in the Mondé family. The first of these is spoken by the Gavião, Zoró, Cinta Larga, and Aruá Indians. The Gavião can easily speak to the Zoró and the Cinta Larga, though there are dialect differences between the three groups. Their cultures are very similar. The Aruá wordlist taken by Campbell (1968) on the Rio Branco indicates to me that their speech would be intelligible to the Gavião also, after a bit of adjustment.

The second language of the Mondé family, that of the Surui Indians, is not really intelligible to the Gavião or to the Cinta Larga. As an impression, Gavião and Surui are about as different as, say, Spanish and Italian. Although the Surui live near the Gavião, Zoró, and Cinta Larga they are rather different in culture.

The language of the Mondé Indians themselves (Hanke 1950) appears to be different from either Gavião or Surui, and, as a guess, this is better considered to be a separate language. The Mondé seem to belong to the culture area of the Guaporé.

In general, the degree of genetic relatedness among languages and language families in Rondônia remains to be established with certainty. More linguistic research in the area could improve this situation greatly and provide interesting evidence about the prehistory of the region.

1.3 The Present Study

Field research was conducted among the Gavião on the P.I. Lourdes from June 1975 to January 1978. About eighty percent of this period

was spent actually in the village conducting linguistic research. The other twenty per cent of the period was spent on occasional trips to resupply, seek medical treatment, and take care of business matters.

The Gavião were selected for this study because there were no published studies of their language or culture except for Schultz (1955). About six of the Gavião men were fluent in Portuguese, which facilitated linguistic work. Conditions for the study were excellent except that the best informants were sometimes unavailable, and after June of 1976 I was sick (with serum hepatitis, malaria, and tropical sprue) more often than healthy.

The primary purpose of the project was to gather data for a grammar of the Gavião language. This was done by traditional linguistic field methods. A working orthography was established only after several months of research mapping out syllable tone and length. After transcribing a few elementary texts and eliciting simple sentences, embedded clauses, and phrases, I was bothered by the lack of adverbs and postpositions, and more bothered by a feeling that the syntax of the language was too radically simple and elegant to be real.

As more texts were transcribed it became clear that the few earlier texts had been kept simple by kindly informants. Much of the syntactic complexity of the language was in the system of particles. These are sufficiently inscrutable that the meaning and syntactic behavior of many of them were only determined after leaving the field. A few are still not understood.

The other major area of syntactic complexity was the system of complex words and complex word stems. The enterprise of writing explicit rules eventually led me to decide that a complex/elementary

distinction and a stem/nonstem distinction were needed to account for Gavião constructions smaller than phrases.

Twenty-three texts of various types were transcribed. This was slow and laborious because whistled comparisons were necessary to establish syllable tone and length for almost every word. The texts average slightly over one hundred sentences each. These have all been selectively slip-filed and provide the primary basis for the analysis of the syntax.

In addition to this work on the Gavião language a few days were spent investigating the language of the Arara Indians and the dialect of the Cinta Larga Indians. A certain amount of data on the culture of the Gavião was obtained, but time limitations prevented thorough research and verification in this area.

The following sections describe the syntax of the Gavião language. Originally I hoped to present a full, explicit description of the phonology and morphology also. Instead, bowing to real-world considerations, I shall present only informal sketches of the phonology (Appendix A) and morphology (Appendix B).

The analysis of Gavião syntax given here is meant to be a comprehensive and explicit description without theoretical commentary. Formalisms are employed, but these are not particularly exotic and the meaning of a formal rule should be clear from the discussion of its motivation and from the explanation of formalisms provided in the Symbols and Abbreviations section. The analysis is not very abstract. Surface structure facts and the motivation for the analysis adopted are given.

The style of analysis is eclectic, following anthropological

tradition. For the most part it follows a style of rather orthodox transformational grammar represented by, for example, Akmajian and Heny (1975). However, there is no reliance on the idea of linguistic universals. In particular, form classes and other syntactic units are defined on a strictly language-internal basis, though with a view to customary usage.

Syntactic features and feature percolation rules are perhaps used more extensively than usual. This was inspired by the practices of Generalized Phrase Structure Grammar, as exemplified in, for example, Gazdar, Pullum, and Sag (1982). This use of syntactic features seems to me to make possible a formal account of a variety of syntactic matters related to Gavião sentence functional types and sentence structural types which is more elegant and natural than would otherwise be possible.

In general, larger constructions are analyzed before their constituents. Phrase structure rules are given for a construction before any transformations affecting it. When crucial data is lacking or when analysis is uncertain this is pointed out and what can be said is said. Certain aspects of the morphology are discussed along with the syntax when these are particularly relevant.

Section 2.0 presents a quick, general overview of major aspects of the syntax of Gavião sentences: sentence/clause composition, the large array of sentence-level particles and other items called 'matrix S elements', sentence structural types, and the elaborate system of sentence functional types and auxiliary stems.

Section 3.0 presents an overview of the syntax of Gavião words, word stems, person prefixes and phrases. Elementary words, elementary

word stems, and person prefixes are defined and illustrated. Complex words, complex word stems, phrases, and form classes are briefly characterized in Section 3.0 (and fully explained in Sections 9.0, 10.0, 11.0, and 12.0.)

Section 4.0 gives the composition of noncopula sentences or clauses in detail (excluding the matrix S elements) and presents a preliminary formulation of the preposing movement transformation which operates within them.

Section 5.0 explains sentences or clauses of the copula structural type and the auxiliary stems which occur in them. A preliminary formulation of preposing within copula sentences is given.

Sections 4.0 and 5.0 are mainly concerned with the common properties of all clauses and their auxiliary stems. Section 6.0, by contrast, discusses in detail the differences in clauses and their auxiliary stems associated with each of the sentence functional types. The meaning and syntactic behavior of matrix and embedded clauses of each of the many sentence functional types is discussed. The feature composition of auxiliary stems of each of the sentence functional types is given.

Section 7.0 returns to matrix S elements in the Pre-S and Post-S nodes. The composition of those nodes and the rules for inserting WH words and discourse pronouns are given. The two preposing operations described earlier are revised and a third preposing operation is formulated. Other, minor, transformations involving matrix S elements are explained.

The sentence-level syntactic rules presented in Sections 4.0 through 7.0 are summarized in Section 8.0.

Section 9.0 explains noun phrases and the form classes which occur in them. Section 10.0 does the same for verb phrases. What can be said about conjunction is presented in Section 11.0.

Section 12.0 first defines phonological words, providing a basis for formally distinguishing complex words and word stems from their elementary counterparts. Then the various types of derived and compound complex words and word stems are examined.

Appendix A is a sketch of Gavião phonology. Appendix B is a sketch of the morphology. Appendix C is an analyzed text.

2.0 OVERVIEW: SENTENCES, MATRIX S ELEMENTS, SENTENCE FUNCTIONAL TYPES, AND SENTENCE STRUCTURAL TYPES

Some of the most basic aspects of Gavião sentence syntax are characterized briefly in this section so as to introduce concepts and present a preliminary overall picture.

2.1 Matrix and Embedded Sentences, S and S'

A matrix S is composed of a shell of matrix S elements (mostly particles) and a matrix S'. The matrix S elements occur in the Pre-S, before the matrix S', or in the Post-S, after the matrix S'. The matrix S' contains a subject NP or a subject person prefix, an auxiliary stem, a predicate NP (if any), verb phrases (if any), and embedded clauses (if any). Example:

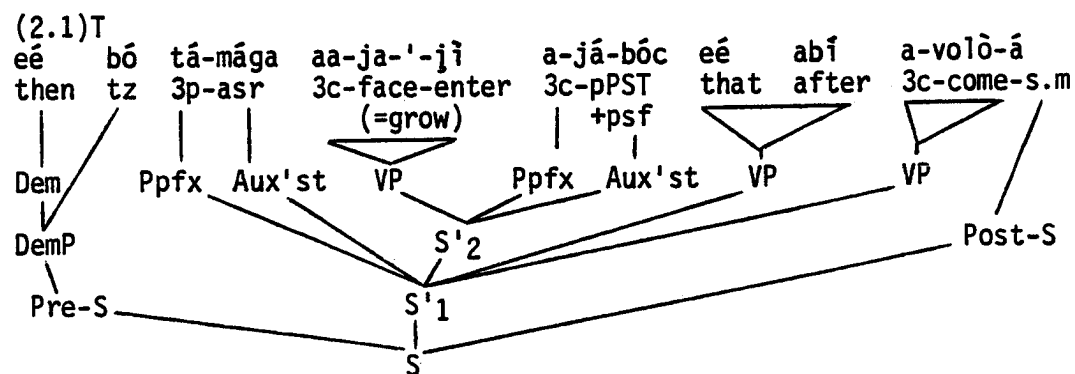

'Then they will arrive after they are already grown.' (The boys who left to hunt the Giant Lizard were gone so long they became adults.)

In example (2.1) the Pre-S and Post-S nodes contain matrix S elements: eé 'then', bó 'topicalization', and -á, a syntactic boundary marker. Such elements (except -á) each occur only once in each S; they do not occur in any S'. So a S can be distinguished from a S' by the potential occurrence of M.S.E.s in the former. Any construction which does not contain an auxiliary stem and which is not a subpart of a

construction which does is considered a sentence fragment.

There are three primary reasons for giving the same S' status to both nodes S'₁ (a matrix S') and S'₂ (an embedded S') above:

(a.) Neither of these clauses can contain M.S.E.s such as eé, a S-initial demonstrative phrase.

(b.) The rules of composition for a matrix S' such as S'₁ and for an embedded S' such as S'₂ are essentially the same. Notice that S'₁ and S'₂ in sentence (2.1) both contain a subject person prefix, auxiliary stem, and one or more VPs.

(c.) Two Gavião movement rules, {VP, S', S'-á} Preposing within S', and Predicate NP Preposing within S', operate in similar fashion inside a matrix S' such as S'₁ and inside an embedded S' such as S'₂ above. As an example of preposing, notice that the VP aa-ja-'-jî 'grow (up)' has been preposed to the front of S'₂, but no preposing has occurred in S'₁, which begins with a prefixed auxiliary stem. The boundaries of an S' are determined by the potential application of the two preposing rules mentioned above.

2.2 Matrix S Elements

There are forty-five M.S.E.s, most of which are particles. Of these, fifteen occur in the Pre-S position and thirty occur in the Post-S. All M.S.E.s are optional in the sense that they can all be dispensed with except in nonassertative sentences. Diagram (2.2) below gives a rough overview of the semantic notions represented in the Pre-S. Of course only a small subset of these can occur in a given sentence. When the S-initial position is vacant a phrase or clause can be preposed into it.

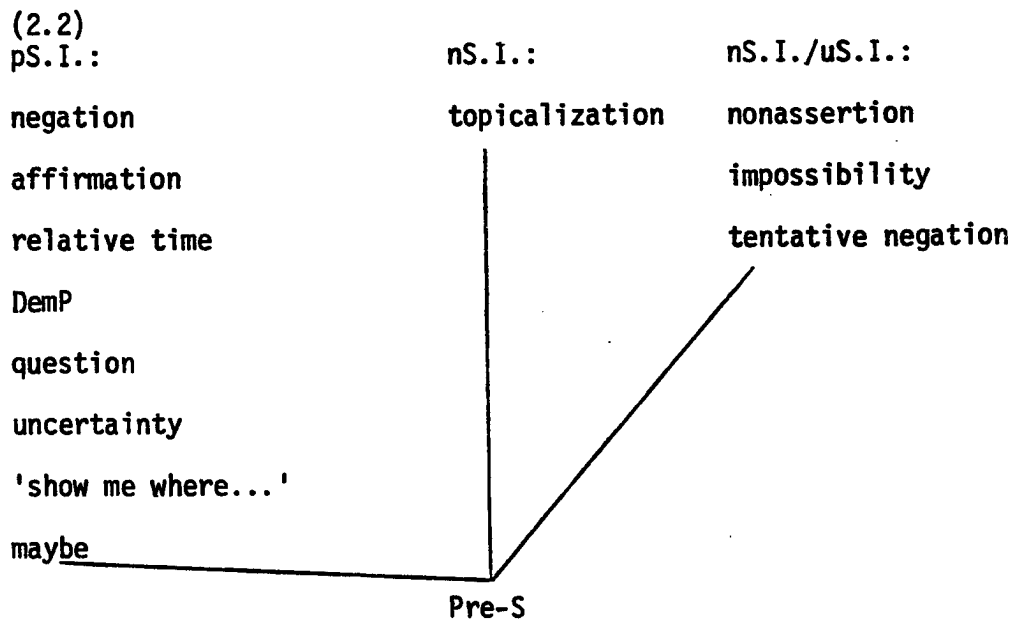

Overview of the semantic notions represented in the Post-S:

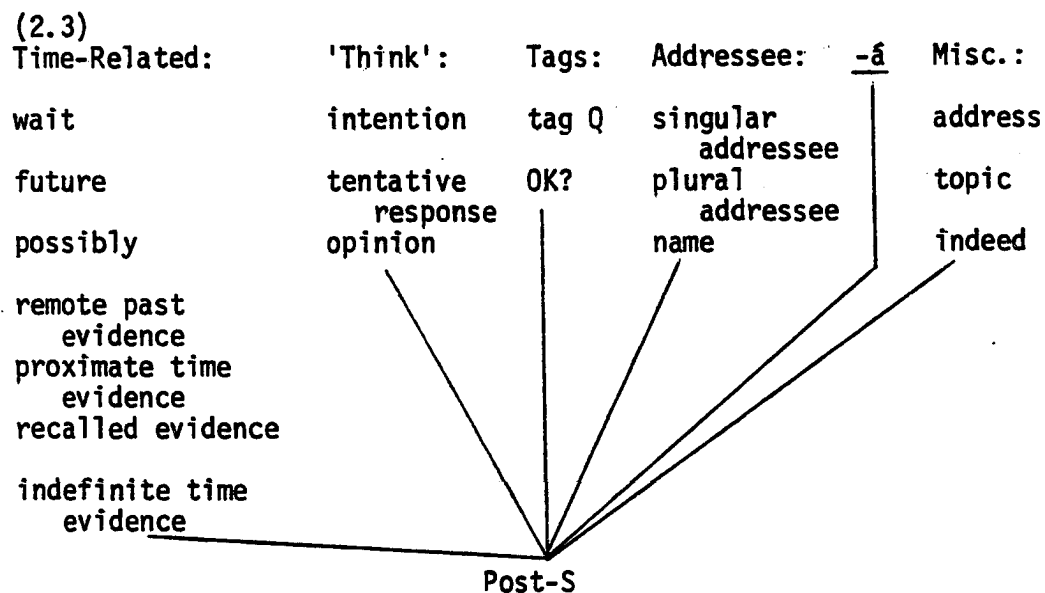

The occurrence patterns of the M.S.E.s are rather complicated. The main syntactic factor determining which M.S.E.s can occur and cooccur in a sentence is its sentence functional type. For example certain M.S.E.s can occur in nonassertions while others are precluded from occurring.

2.3 Sentence Functional Types

Eleven sentence functional types have been distinguished. They are represented formally as values of the syntactic feature S.F.TY. The features are spread in the expansion of S to its constituent Pre-S, matrix S', and Post-S. When S' is rewritten its S.F.TY value is spread to its Aux stem. This is diagrammed below.

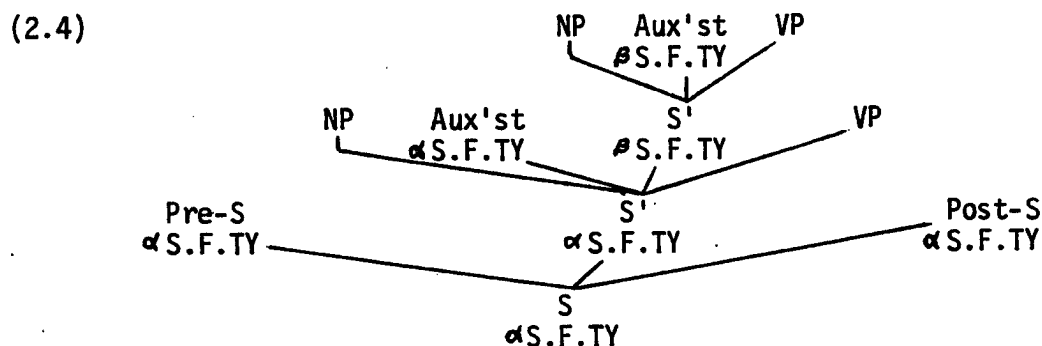

Some illustrative examples of each of the sentence functional types are given below. For each Aux stem all the aspect, mood, and sentence functional type features and their values are indicated. However, all examples are noncopula (nCOP) and unmarked for motion (uMOT), and these features are not indicated. A sentence-initial demonstrative begins the matrix Ss except in the prohibitive and exhortative Ss, where it is prohibited. The simulfactive, postfactive, and nominal examples are just embedded clauses; that is, each is just a S' with no matrix S or matrix S'.

Assertative:

(2.5) eé zāno mǎa ga tírí
 there 1s+bro pPST+uDEF+uDUR+nSJV+asr w+field burn

'My brother was burning the field there.'

Nonassertative:

(2.6) eé té zāno já ga tírí
 there nasr 1s+bro pPST+nDEF+uDUR+nasr w+field burn

'My brother was burning the field there.' (Suggestion)

Imperative:

(2.7) eé e-já ga tírí ále
 there 2s-nPST+nDEF+nDUR+imp w+field burn fut

'Burn the field.'

Prohibitive:

(2.8) e-já ga tírí ále
 2s-nPST+nDEF+nDUR+proh w+field burn fut

'Don't burn the field.'

Exhortative:

(2.9) e-béré ga tírí
 2s-nPST+uDEF+uDUR+exh w+field burn

'Burn the field.'

'Let':

(2.10) eé zāno já-àt ga tírí
 there 1s+bro uPST+uDEF+uDUR-let w+field burn

'Let my brother burn the field there.'

Preventative:

(2.11) eé zāno já ga tírí
 there 1s+bro uPST+uDEF+uDUR+prev w+field burn

'Don't let my brother burn the field there.'

Desiderative:

(2.12) eé zāno jā-r+ava ga tírí
 there 1s+bro nPST+uDEF+nDUR-des w+field burn

'It would be good if my brother burns the field.'

Simulfactive:

(2.13) zāno sá-ât ga tírí
 1s+bro uPST+uDEF+uDUR-sim w+field burn

'when my brother burns the field'

Postfactive:

(2.14) zāno jā-bóc ga tírí
 1s+bro pPST+uDEF+uDUR-psf w+field burn

'after my brother burned the field'

Nominal:

(2.15) zāno jā-nêê ga tírí mát
 1s+bro pPST+uDEF+uDUR-psf w+field burn sb.nz

'my brother who burned the field', or, 'the field my brother burned'

These sentence functional types differ from each other semantically or pragmatically, as can be seen by the translations. These sentence functional type distinctions are needed to account for a wide range of grammatical facts:

(a.) Auxiliary stem morphology. Several sentence functional types manifest themselves on Aux stems as overt final segments (e.g. the -bóc of jā-bóc in (2.14) above).

(b.) The cooccurrence of auxiliary stem features. For example, the imperative, prohibitive, and exhortative auxiliary stems are

always nCOP and cannot occur in copula sentences, but auxiliary stems with the other sentence functional type values can. Auxiliary stems of these same three sentence functional types always have nPST tense. Most sentence functional type values restrict which other feature values can cooccur with them on auxiliary stems.

(c.) Clause (S') distribution. For example, a S' of the simulfactive, postfactive, or nominal sentence functional type (2.13-15) can only be immediately dominated by S', not by S. Of these, the nominal is obligatorily nominalized. The sentence functional type distinctions allow such facts to be stated in a straightforward way.

(d.) Cooccurrence of matrix S elements with the auxiliary stems and with each other. For example, the set of time-of-evidence particles contains two subsets: one occurring in assertative sentences and the other occurring in nonassertative sentences.

(e.) Preposing of predicate phrases and clauses. For example, this is disallowed in the case of prohibitives, but is obligatory if necessary to prevent an assertative Aux stem prefix from becoming matrix S initial.

2.4 Sentence Structural Types

There are three Gavião sentence structural types. The first of these, the noncopula type, is far more frequent than the other two. The Aux stem in a noncopula S' is marked nCOP, and there is no predicate nominal in the S'. The S' optionally contains VPs and embedded clauses. When there is no VP the sentence asserts the existence of the subject or indicates that the subject is doing something. A negative example with no VP:

(2.16)T

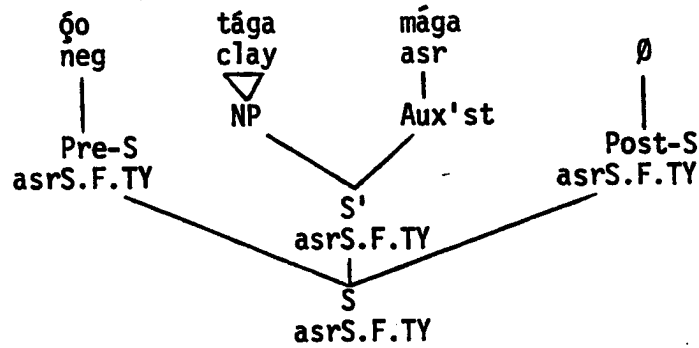

'There is no clay.'

Example with one VP:

(2.17)T

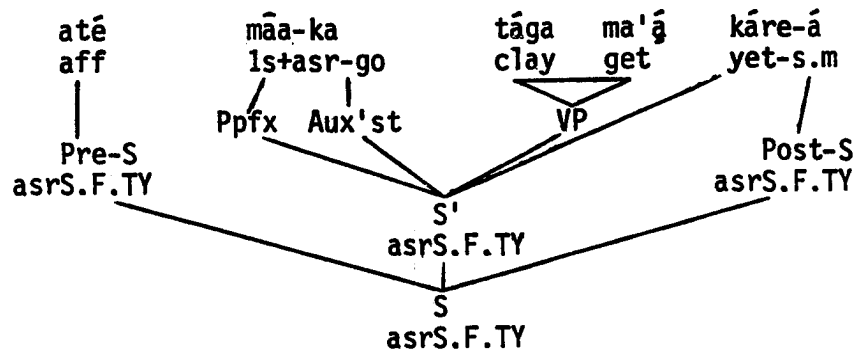

'I'll go get clay yet.'

The copula sentence structural type contains an Aux stem marked pCOP and a predicate nominal. A copula sentence equates the subject NP or subject person prefix with the predicate NP. Some VPs can occur in copula sentences, but many cannot. This sentence structural type is rather uncommon. Example with the predicate NP preposed:

(2.18)T

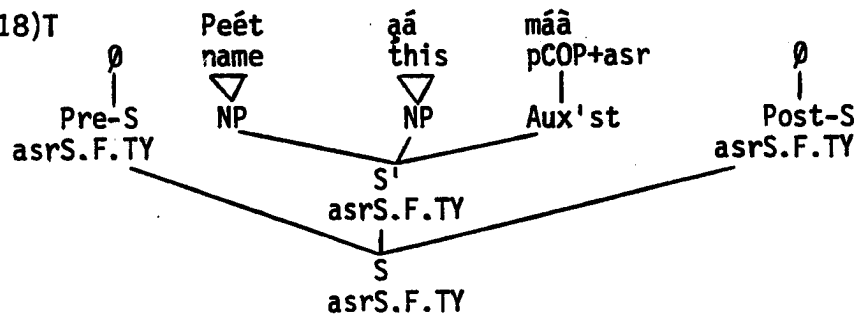

'This is Peét.'

The third sentence structural type is very rare. It contains no predicate nominal, and it is not clear if VPs can occur within it or not. I will assume that there is a feature, pCOMING, which occurs on Aux stems in sentences of this structural type. Sentences which are pCOMING assert that the subject is coming. Informants insist on this meaning although there is no overt morpheme meaning 'come' in such sentences.

Auxiliary stems which are pCOMING may be assertative or nonassertative:

- (2.19) //mää// //yá//
 pCOMING+asr pCOMING+nasr

These pCOMING Aux stems are phonetically identical to several other Aux stems (see the Aux stem tables in Sections 5.0 and 6.0), creating serious problems of ambiguity. The pCOMING interpretation seems to be dependent on context and seems to be much less likely if VPs are present. This sentence structural type is very marginal, and no more will be said about it. One naturally occurring example from a soccer game is given below.

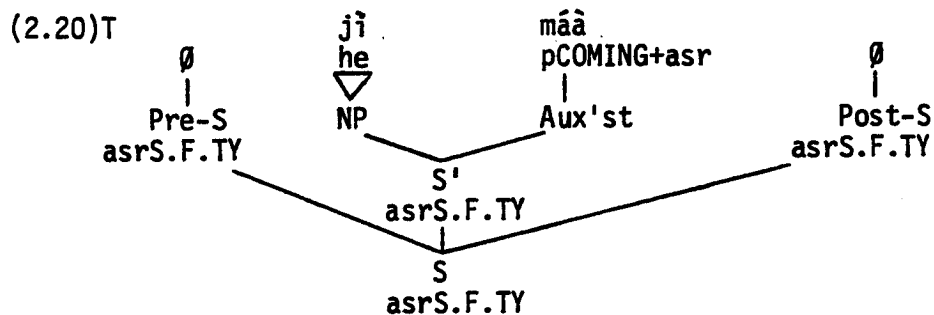

'Here he comes.'

3.0 OVERVIEW: WORDS, WORD STEMS, PERSON PREFIXES, AND PHRASES

The three basic minimal units of Gavião syntax are elementary words, elementary word stems, and person prefixes. These are characterized quite fully in this section.

A phonological word in Gavião is a construction of one or more morphemes which is bounded by external open junctures and which contains no external open junctures within itself. (Phonological words and juncture types are explained in Section 12.0.) A phonological word corresponds to the usual intuitive notion of a word as a unit which is a minimal free form: it is readily pronounceable in isolation and enters freely into syntactic constructions with other words (i.e. is not bound). A phonological word may be an elementary word, an elementary word stem, or an elementary word stem with attached person prefix.

Both words and word stems may be either elementary (marked with a prime, e.g. V') or complex (unmarked, e.g. V). The system of complex words and word stems in Gavião is quite complicated. By contrast, Gavião phrases are rather simple in structure. Phrases are discussed in detail in Sections 9.0 and 10.0; complex words and complex word stems are treated in Section 12.0. So these will receive only a preliminary characterization in this section.

3.1 Elementary Words

Elementary words are single phonological words which do not contain person prefixes, which cannot be prefixed for person, and which (with the exception of some particles) do not form constructions with immediately preceding nominal expressions (e.g. noun phrases, noun stems, etc.). There are five classes of elementary words: nouns (N'),

verbs (V'), pronouns (Pro), demonstratives (Dem), and particles (Prt). The classes are mutually exclusive. The first four are minimal free forms in the fullest sense: they can be short answers or minimal phrases. Particles are pronounceable in isolation but are less acceptable as free forms since their meaning is usually grammatical.

Of the elementary words, pronouns, demonstratives, and particles never have corresponding elementary word stems. However, all non-derived elementary nouns and some elementary verbs do. Many elementary nouns have phonetically identical corresponding noun stems:

(3.1)	N'	NP N'st	2s-N'st	Base
	ákápe mat	gaác ákápe mother mat	eé-kápe 2s-mat	//ákápe//
	'mat'	'mother's mat'	'your mat'	
	ini hammock	gaác ini mother hammock	eé-ni 2s-hammock	//ini//
	'hammock'	'mother's hammock'	'your hammock'	

In these cases morphemes such as ákápe and ini are considered to be both elementary nouns and elementary noun stems.

Some elementary nouns are derived from elementary noun stems of the //e-// prefix class by voicing of the initial obstruent:

(3.2)	N'	NP N'st	2s-N'st	Base
	dábe w+axe	gaác tábe mother axe	e-dábe 2s-axe	//tábe//
	'axe'	'mother's axe'	'your axe'	
	bosap w+pot	gaác pōsap mother pot	e-bōsap 2s-pot	//posap//
	'pot'	'mother's pot'	'your pot'	

In these cases the elementary nouns are considered to consist of a word-deriving prefix, w, and an elementary noun stem.

Elementary nouns are less numerous than elementary noun stems since many elementary noun stems do not have corresponding elementary nouns. For example, some of these stems are inalienably possessed:

(3.3)	*N'	NP N'st	2s-N'st	Base
	*zac wife	vaavã̃a sac shaman wife	ẽ-zac 2s-wife	//say//
	*'wife'	'shaman's wife'	'your wife'	
	*ádaát head	vaavã̃a ádaát shaman head	eé-dáát 2s-head	//ádaát//
	*'head'	'shaman's head'	'your head'	

Elementary verbs differ from elementary nouns in that the verbs do not generally have corresponding elementary verb stems:

(3.4)	V'	*V'st
	bã̃gã̃a 'darken'	(no corresponding stems)
	ibalã̃a 'dance'	
	póã̃a 'blow'	

Elementary verb stems do not generally have corresponding elementary verbs, but a few elementary verbs are formed from elementary verb stems preceded by the w derivational prefix (voicing):

(3.5)	V'	2s-V'st	Base
	<u>b</u> asanã̃a 'steal' w+steal+from	e-básanã̃a 'steal from 2s-steal+from you'	//pásã̃t+ã̃//
	<u>g</u> erẽ 'sleep w+sleep elsewhere'	e-gerẽ 'you sleep' 2s-sleep	//ket+ẽ//

In the above, pásanà is an elementary transitive verb stem and kerè is an elementary cross-referencing verb stem.

3.2 Elementary Word Stems

An elementary word stem is a single phonological word which can be prefixed for person or which can form a construction with a preceding nominal expression. When prefixed for person the person prefix plus stem is a single phonological word. For example, the following NP contains three phonological words, but four minimal syntactic units: one prefix and three elementary word stems:

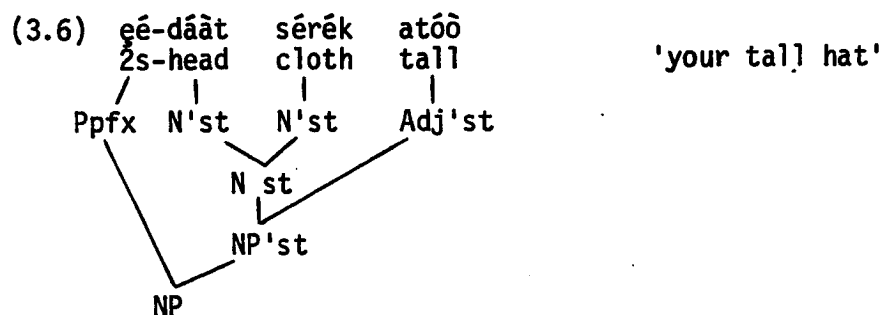

Unlike elementary words, elementary word stems are not minimal free forms in the fullest sense. They are pronounceable in isolation but cannot be short answers or minimal phrases. If the word 'tall' or 'cloth' is elicited an informant never gives atóò or sérék as in (3.6), but rather:

- (3.7) taa-tóò '(something) tall'
 3s-tall
- zérék
 w+cloth 'cloth' (noun)

Notice that a person prefix plus an elementary word is a phonological word but not a syntactic word. In (3.6) above the prefix does

not form an immediate constituent with the elementary word stem 'head', but rather with a syntactic unit (NP'st) composed of three elementary word stems: 'head', 'cloth', and 'tall' ('tall hat', a complex noun stem modified by an adjective stem).

There are four mutually exclusive classes of elementary word stems: noun stems (N'st), verb stems (V'st), adjective stems (Adj'st), and auxiliary stems (Aux'st). Verb stems may be transitive (V'st.t) or cross-referencing (V'st.c). Unlike a word, a word stem must be preceded by a person prefix (possibly a zero morpheme) or by a nominal expression. Each elementary word stem belongs to one of four person prefix classes, most conveniently designated by their second person singular forms: //e-//, //é-//, //eé-//, and //éè-//. Examples (all of the //e-// prefix class) showing the parallelism of person prefixation across the four elementary word stem classes:

(3.8)	2s-stem	Postnominal Stem	Base
N'st	e-bábe 2s-hand	vɔavɔã pábe shaman hand	//pábe//
	'your hand'	'shaman's hand'	
V'st.t	e-dírí 2s-burn	vɔavɔã tírí shaman burn	//tírí+í//
	'burn you'	'burn shaman'	
Adj'st	e-bôôc 2s-big	vɔavɔã pôôc shaman big	//pô+ô+y//
	'you, big'	'big shaman'	
Aux'st	e-zá 2s-nasr	vɔavɔã sá shaman nasr	//sá//
	'you are'	'shaman is'	

Person prefix class membership is a property of the whole

elementary word stem, not of its leftmost morpheme. Compare:

(3.9)	êè-baàt 2s-sister	e-bâr-âpit 2s-sister-child
	'your sister' (//êè-// class)	'your sister's daughter' (//e-// class)
	ê-jîit 2s-blood	ê-jîr-alâ 2s-blood-fall
	'your blood' (//ê-// class)	'you menstruate' (//e-// class)

Elementary noun stems are subcategorized for 'nominal construction type'. These subcategorization features are also properties of the elementary noun stem, not of its leftmost morpheme. Compare:

(3.10)	eé-dâat 2s-head	*âdâat head
	'your head'	*'head' (inalienably possessed)
	eé-dââr-ââp 2s-head-ho w.o	âdââr-ââp head-ho w.o
	'your headdress'	'headdress' (alienably possessed)

3.3 Person Prefixes

Person prefixes are phonologically bound morphemes which specify person and number. They constitute a closed set specifiable by enumeration (given in Appendix B). Membership of a stem in a prefix class is in part phonologically determined, in part arbitrary. Each of the prefix classes is briefly illustrated below, though only a few prefixes are shown at this time. Words formed from word stems with the w prefix are given in parentheses. The third person singular and postnominal forms of cross-referencing verb stems are given in parentheses because these forms only occur when the stem is part of a

complex word stem. Otherwise only cross-referencing prefixes occur.

(3.11) //e-// Class Prefixes:

	N'st	V'st.t	V'st.c	Adj'st	Aux'st
	'path'	'rob'	'get dry'	'burning'	asr
2s	ɛ-bé	ɛ-básanà	ɛ-gáɣà	ɛ-gâac	e-mága
3s	ci-pe	pásanà	(káɣà)	kâac	mága
3c	a-pe	a-pásanà	a-káɣà	a-kâac	--
Post-nominal	pé	pásanà	(káɣà)	kâac	mága
Word	(be)	(basanà)	--	--	--

(3.12) //é-// Class Prefixes:

	N'st	V'st.t	V'st.c	Adj'st	Aux'st
	'wife'	'cover'	'sleep'	'old'	pPST+asr-go
2s	é-zac	é-bogô	é-gerè	é-gâac	é-ma-káá
3s	ci-sac	pogô	(kerè)	kâac	ma-káá
3c	a-sac	a-pogô	a-kerè	a-kâac	--
Post-nominal	sac	pogô	(kerè)	kâac	ma-káá
Word	--	--	(gerè)	--	--

(3.13) //eé-// Class Prefixes:

	N'st	V'st.t	V'st.c	Adj'st	Aux'st
	'mortar'	'follow+plX'	'shout'	'standing'	pPST+pDEF-nom
2s	eé-kabîî	ɛé-bemáá	eé-pɛè	ɛé-dôô	eé-néè
3s	saa-kabîî	saa-bemáá	(saa-pɛè)	taa-dôô	ánéè
3c	aa-kabîî	aa-bemáá	aa-pɛè	aa-dôô	áá-néè
Post-nominal	ákabîî	ábemáá	(ápɛè)	ádôô	ánéè
Word	akabîî	--	--	--	--

(3.14) //éè-// Class Prefixes:

	N'st	V'st.t	V'st.c	Adj'st	Aux'st
	'liver'	'pass by'	'go'	'tall'	(no //éè-// class)
2s	éè-zaá	éè-gáá	éé-gaà	éè-tóò	
3s	cii-saá	saa-gáá	(kaà)	taa-tóò	
3c	aa-saá	aa-gáá	aa-kaà	aa-tóò	
Post-nominal	saá	agáá	(kaà)	atóò	
Word	--	--	--	--	

The prefix abbreviated '3c' is a cross-referencing prefix on cross-referencing verb stems and a coreferential (with subject) prefix on transitive verb stems, nominal expression stems, and auxiliary stems. (Coreference and cross-reference are discussed in Section 6.4.)

Prefixes are introduced as syntactic units in the same way as, say, NPs. The prefixes eventually are attached to their stems, but this attachment will be considered a phonological matter and will not be dealt with in this paper.

Cross-referencing verb stem prefixes only indicate agreement. They are not functionally equivalent to pronouns since cross-referencing verb stems do not form constructions with pronouns. Other prefixes are functionally equivalent to pronouns. Auxiliary stem prefixes are S' subjects; noun stem prefixes are possessors or arguments of the noun stem; adjective stem prefixes are NP heads modified by the adjective stem; and transitive verb stem prefixes are direct objects.

Notice that the third person singular prefix translates as 'his, her, its' on noun stems, as 'something' on adjective stems, and as either 'him, her, it' or 'something' on transitive verb stems:

- (3.15) saa-kabīī 'his or her mortar'
 3s-mortar
- taa-dōò '(something) standing'
 3s-standing
- saa-bemāā 'follow him, her, it, or something,
 3s-follow+plX plural action'

The 'postnominal' form of a stem is the form which appears following a nominal expression. In, for example, nekô saā 'cat's liver', saā 'liver' is postnominal. The initial syllable of an //e-// or //eé-// class stem has high tone in postnominal form, even if this tone is nonhigh in the base form of the stem.

3.4 Complex Words and Complex Word Stems

Complex words and word stems distribute within the phrase like elementary words and word stems, respectively. One type of complex noun can consist of a single phonological word containing a person prefix; otherwise all complex words and word stems are composed of two or more phonological words. A compound complex noun stem (N st) in a NP:

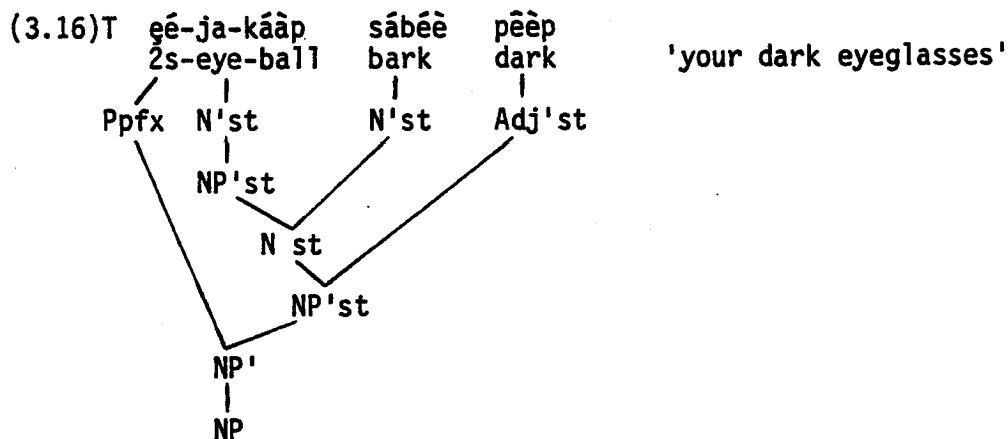

An example of a derived complex adjective stem (Adj st) in a NP:

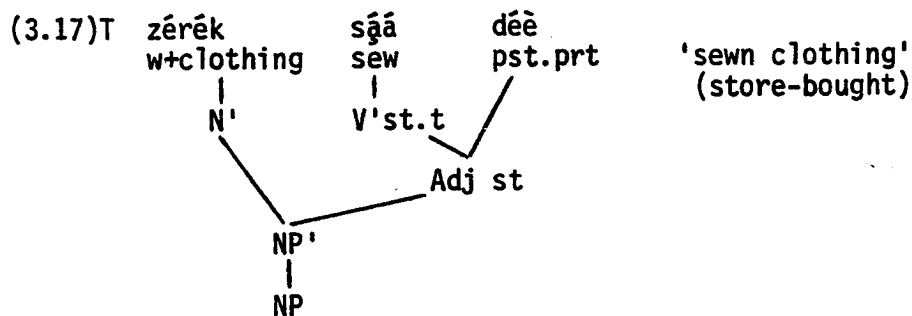

3.5 Verb Phrases, Verbs, and Verb Stems

A verb phrase may be defined syntactically as any construction which can be preposed by the rule {VP, S', S-á} Preposing within S' and which is not an embedded clause. That is, one VP can be preposed to the front of a noncopula S', and this provides an excellent operational means of identifying VPs and their boundaries. All VPs can be nominalized with the particles mát or méne, and probably all VPs can be negated with the particle qòp under the right semantic circumstances.

There are three types of VPs in Gavião: transitive VPs, cross-referencing VPs, and VPs consisting of a verb. A transitive VP consists of a direct object NP or person prefix followed by an elementary or complex transitive verb stem:

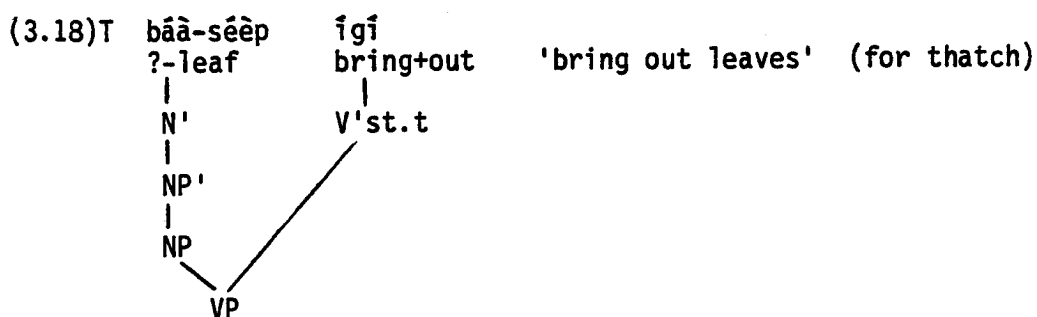

A cross-referencing VP consists of a cross-referencing person

prefix (which agrees in person and number with the clause subject)
followed by an elementary or complex cross-referencing verb stem:

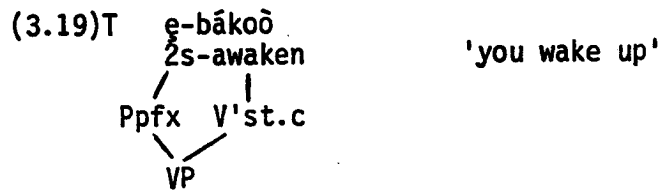

The third type of VP contains a single elementary or complex
verb (not a verb stem):

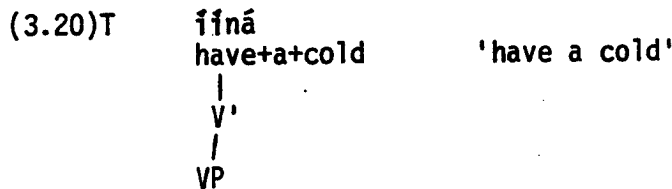

Any of these three types of VPs can be modified by following
qualification particles, such as téét 'exactly'.

3.6 Noun Phrases, Nouns, Noun Stems, Demonstratives, and Adjective Stems

A noun phrase is defined as any unit or construction which can occur before the auxiliary stem as the subject of a sentence or which can occur as a direct object before a transitive verb stem and which is not a person prefix. All NPs, and only NPs, can be verbalized with the particle ná.

Some NPs contain a possessor constituent (a NP or person prefix) immediately preceding the head of the NP, and some do not. If a possessor is present, then the head of the NP is an elementary or complex noun stem. It can be followed by one or more elementary

or complex adjective stems. The noun stem head of the NP and any following adjective stems form a constituent which will be called a NP' stem. This and its preceding possessor form a NP':

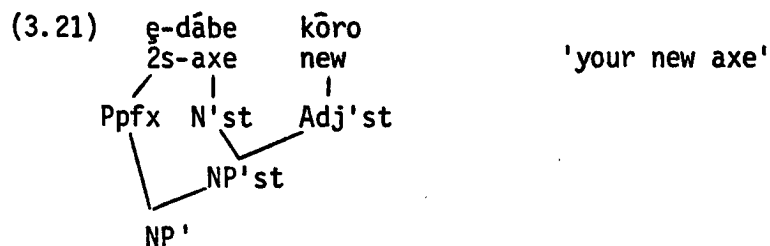

A NP' which does not contain a possessor element has as its head either an elementary or complex noun, a pronoun, a demonstrative or a person prefix. The head can be followed by one or more elementary or complex adjective stems, obligatorily if the head is a person prefix. A NP' example with an elementary noun head:

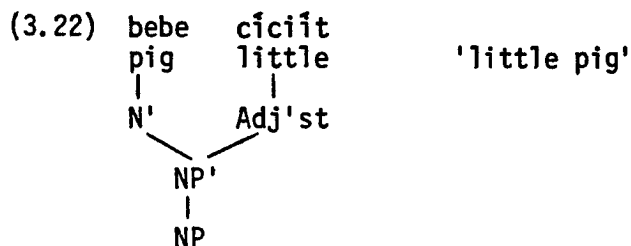

A NP' may be modified by a preceding demonstrative, and a NP may be modified by a following qualification particle:

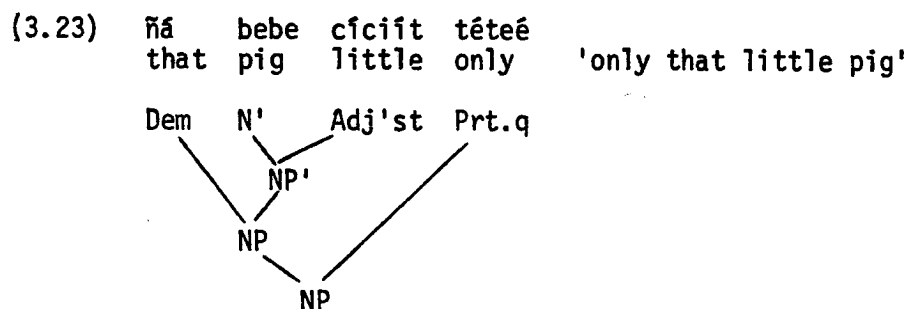

Demonstratives are distinguishable from pronouns in that the former can modify a NP' but the latter cannot. Both of these are closed sets, specifiable by enumeration. Elementary nouns are elementary words which can be NP heads or minimal NPs by themselves, but which are neither demonstratives nor pronouns. An elementary noun stem is distinguishable from an elementary noun in that the former can stand in construction with a preceding person prefix or nominal expression. Elementary adjective stems can occur (in potentially large numbers, one following the other) modifying the preceding head of the NP which contains them. Noun stems and adjective stems can easily be distinguished from verb stems since noun or adjective stems prefixed for person are NPs, whereas verb stems prefixed for person are VPs.

3.7 Auxiliary Stems

Auxiliary stems constitute a closed set and can be defined by listing. A table of these is given in Section 6. Auxiliary stems can also be defined as words which occupy a fixed position in a S' after the subject NP or subject person prefix.

Auxiliary stems and transitive verb stems share some properties. Both occur after a NP or person prefix. The nonsubjective, nonpast, assertative Aux stem, mága, has the same phonetic form as the transitive verb stem mága 'make, put'. These can both be contracted to māa.

However, there are many reasons for considering auxiliary stems and verb stems as different categories. The syntactic arguments are as follows:

- (a.) The Aux stems occupy fixed positions within the sentence. Verb stems occupy a fixed position within the VP, but the VPs can

occur in any order and can be preposed within S' and also into S.

(b.) Aux stems cannot generally be immediately followed by the negative particle, ôp, though verbs stems can be. Likewise, Aux stems cannot in general be immediately followed by the nominalization particles, mât and méne, as can all verb stems.

(c.) There are no transitive verb stems in Gavião which take unnominalized VP complements, so if an Aux stem were a verb it would not take the following VPs as complements in the manner proposed by some analyses of English auxiliary verbs.

The morphological arguments indicating that Aux stems are a separate category from verb stems are as follows:

(d.) Aux stems are marked for tense, aspect, mood, motion, and sentence functional type, but verb stems are not. This is in some ways the reverse of the case for English.

(e.) Aux stems are not marked for plural, whereas many verb stems are. For example, mâga 'make, put', takes singular objects, its suppletive form for plural objects is mâkiî. The Aux stem, mâga, has no plural.

(f.) Aux stems do not take the intransitivizing prefix, -vé-, as transitive verb stems do. They lack the stem formative vowel reduplication which is usual for verb stems. They do not take the nominalizing suffixes //-t//, //-p//, and //-ve//, which verb stems usually take.

It would be difficult to consider the Aux stems to be a concatenation of particles because M.S.E. particles neither accept person prefixes nor occur sentence medially, and some Aux stem features do not have consistent overt expression.

There seems to be no one feature or segment which is clearly the head of an Aux stem. Semantically it seems to have no meaning other than that of its features. The category could just as well be called 'sentence feature cluster', but 'auxiliary' is more traditional and more intelligible.

3.8 Particles

A particle can be defined as an elementary word which cannot be a minimal phrase. That is, it is neither a noun, pronoun, demonstrative, or verb. The matrix S elements are mainly particles, all of which occupy fixed positions in the sentence. There are six qualification particles which occur only phrase finally. There are also ten derivational particles, which derive complex words, and one conjunction particle.

4.0 NONCOPULA S' COMPOSITION

Each matrix S must contain at least one S', that which is introduced by rewriting S:

(4.1) S Composition:

$$S \rightarrow \alpha S.F.TY \quad \text{Pre-S} \quad - \quad S' \quad - \quad \text{Post-S} \\ \alpha S.F.TY \quad \alpha S.F.TY \quad \alpha S.F.TY \quad \alpha S.F.TY$$

Where α can be asr, nasr, imp, proh, let, prev, or des.

Rule (4.1) introduces a matrix S'. Some S's also occur as embedded clauses in the predicate of another S', functioning much like a VP. Others occur in complex nouns which function as relative/complement clauses. All of these S's, matrix or embedded, have the same structure, which is discussed in this section. Only noncopula S's will be discussed at this point, however.

4.1 Multiple, Independent VPs, S's, and S'-ás

Verb phrases will be discussed first. The most striking fact about the Gavião S' is that it can optionally contain any number of VPs, which occur in any order. There is no change in meaning when the order of the VPs is scrambled, except that any VP occurring before the subject NP or subject prefix is more prominent. The VPs are underlined in the examples below. In each of these sentences any VP can be interchanged with any other with no change in meaning except loss or gain of prominence.

(4.2)T eé bó pa-zé-e-na pa-vân-ga
then tz lpi-pSJV+asr-th-1k lpi-running-cause

ma'ê-e-na sa-ge-ê-na kí-nap
(3s)-get-th-1k 3s-kill-th-1k ev-ndef.tm

'Then we run after it, killing it.'

(4.3)T peja teé pa-á mé-e ná aza aka
 fan cont lpi-pSJV+asr other-pl vz paca kill

má vã ká kí-nap
 some hole in ev-ndef.tm

'Another way to kill paca in the burrow is by fanning.' (or: 'We also fan (smoke) to kill paca in the burrow.')

(4.4)T aáv-á. bicaã-i eé pát sé-e-na
 yes-s.m night-use that type pSJV+asr-th-1k

a-vêre--té-e-na darã kí-nap
 3c-walking-be-th-1k easily ev-ndef.tm

'Yes. At night that type walks (around) a lot.'

In sentence (4.3) 'fanning' is preposed because it is being introduced as another hunting method. In sentence (4.4) 'at night' is preposed to foreground the fact that the animal can be readily encountered at night as opposed to during daylight.

The multiple, independent VPs give rise to a certain amount of ambiguity since it is not always clear (to a non-Gavião) whether a VP applies to the subject or to the direct object. In example (4.5) below the subject is in the tree, but in (4.6) the direct object is in the tree, rendering the sentence semantically unacceptable:

(4.5)A ĩip ká e-mãã
 tree in 2s-pPST+asr 'You were in a tree.'

(4.6) *ĩip ká e-mãã iitiĩ aka *'You killed a deer
 tree in 2s-pPST+asr deer kill in a tree.'

Sentence (4.6) would be acceptable if 'from' were substituted for 'in'. Apparently there are conventions of construal to

disambiguate such matters, but these do not depend on the ordering of the VPs: (4.6) is still bad even if the VPs are exchanged. The interchangeability of VPs indicates that these are not serial verbs or sequentially chained clauses. There seems to be some kind of restriction that all the cooccurring VPs in one sentence must be part of the same event in some sense. For example, one cannot go to the forest and return in the same simple sentence.

In a noncopula sentence a NP must be either the subject or the direct object of a verb. Indirect object NPs appear as the objects of the postpositional transitive verb stem kac 'involving':

(4.7)T e-géré sep noò kaj-á
 2s-exh+go 1f.o give (3s)-involve-s.m

'Go give him the photo.'

The verb stem kac takes as its object not only indirect objects, but, much more generally, almost any NP which is involved in some way in the action but which is neither the object of another, more specific, verb stem nor the subject of the sentence:

(4.8)T "'maá-káâp ígí-i kalâ mâga jî-îc
 1s+pea-nut remove-nsb.nz want 1s+asr 3s-pl

kaj-á' máâ kaj-á" kí-ip
 involve-s.m (3s)-pPST+asr (3s)-involve-s.m ev-rc1

'"I want them to harvest my peanuts", he said to him.'

(4.9)T pa-vít viî té pa-zâ eé pí kac
 1pi-food cook nasr lpi-nasr that after (3c)-involve

'We cook our food with it after that.' (after making the pot)

The only significant movement operations of major lexical

categories in Gavião syntax are three transformations preposing phrases or clauses. Much of the syntactic work of the language is done in the complex words instead of in the composition of clauses or movements within them.

S's of four sentence functional types (sim, psf, let, and des) can occur as embedded clauses, directly dominated by another S'. Of these, the simulfactive and postfactive S's can only occur as embedded S's. The 'let' and desiderative S's can occur as embedded clauses marked with the syntactic marker -ã, or they can appear as matrix S's dominated by S. The possibilities under S' are diagrammed below:

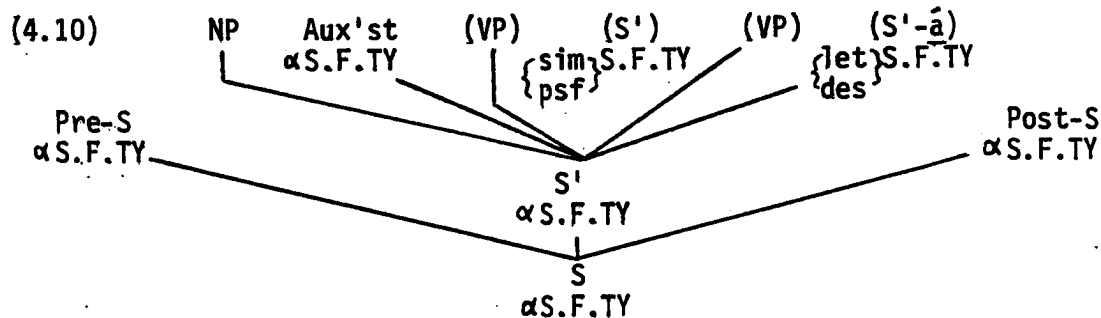

In (4.10) the positions of the VPs and embedded clauses are completely interchangeable with each other. The embedded clauses (S's) exhibit the same free movement possibilities as VPs. Below are two examples of embedded S's dominated by matrix S's. Notice that the third person coreferential prefix is used within the lower S' to indicate coreferentiality with the subject of the higher S'. The lower S' is underlined:

(4.11)T ðo máã bíp tá a-sá-ât jê-na kâre-ã
 neg (3s)-pPST+asr child with 3c-sim that-1k yet-s.m
simulfactive S'

'She wasn't pregnant yet when she was there.'

(4.12)T mā aka té jĩ-ĩc já
 other kill nasr 3s-pl pPST+nDEF+uDUR+nasr

vê-ĩgĩ vā-bóc a-pi
 1s+intr-remove 1s+pPST-psf 3c-from
 postfactive S'

'They killed the other (person) after I left them.' (This is Cinta Larga usage. In Gavião the assertative sentence functional type would be used.)

In sentence (4.11) the positions of the VP jê-na 'like that' and of the embedded simulfactive S' could be reversed with no change in meaning. Likewise, in sentence (4.12) the positions of the VP mā aka 'kill other' and of the postfactive S' could be reversed.

Two examples of S'-á embedded clauses dominated by S' are given below. Again, the 'let' and desiderative S'-á embedded clauses in (4.13) and (4.14) could switch positions with any VP in the sentence.

(4.13)T aāv-á. pa-já-át díá aá mákĩ-á
 yes-s.m 1pi-let soon ft.o (=rubber) make+pl.o-s.m
 'let' S'-á

pa-māa-ka, eé koc teé kĩ ále
 1pi-asr-go that at cont again fut

'Yes. To (let us) make rubber quickly, we'll go there together again.'

(4.14)A e-gerè e-já-r+ava díá teé-á mää
 2s-sleep 2s-uDEF+nDUR-des soon cont-s.m 1s+pPST+asr
 desiderative S'-á

é-gaj-á
 2s-involve-s.m

'I wanted you to sleep soon.'

Aside from coreferential anaphora no syntactic process operates across embedded clause boundaries. There is no extraction from an embedded clause; it moves as a unit.

4.2 Noncopula S' Composition Rule

The composition of noncopula S's is given below:

(4.15) Noncopula S' Composition:

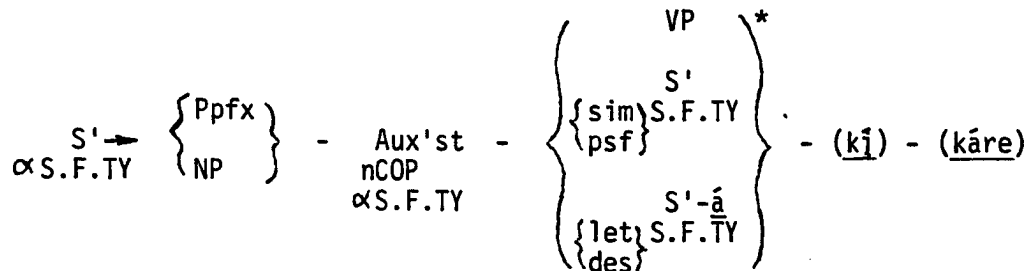

This rule states that a S' of a certain sentence functional type must contain a subject person prefix or NP followed by an Aux stem marked for the same sentence functional type. Optionally any number of VPs, S's, and S'-ás can follow. An embedded S' is simulfactive or postfactive, and a S'-á is of the 'let' or desiderative type. Two optional aspectual particles, kí 'again', and káre 'yet, still', seem to occur within the S', based on the following example where káre immediately precedes the -á of a S'-á embedded clause:

(4.16)A já-àt a-kerè káre-á tá-máà kaj-á
 (3s)-let 3c-sleep yet-s.m 3p-pPST+asr (3c)-involve-s.m

'They let him sleep.'

I will assume that rule (4.15) is fully iterative, permitting in principle the generation of indefinite levels of embedding. This assumption seems safe although there are no text examples which prove the necessity for vertically stacking more than two S's.

Under a certain set of conditions, one VP, S', or S'-á can occur to the left of the subject. It is much easier to generate these items

to the right of the Aux stem and then prepose one by transformation than it is to try to generate one to the left of the subject under the correct set of conditions. This will be seen more clearly in the discussion of preposing below.

It is not certain that the S' constituent structure is correctly given by rule (4.15) although it places items in their proper linear order. Below are diagrams showing three possible analyses of S' structure (omitting the aspectual particles). The first, (4.17), is that specified by rule (4.15) and adopted here.

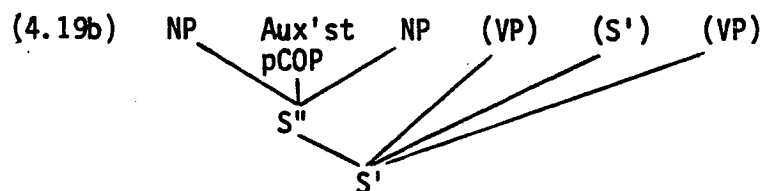
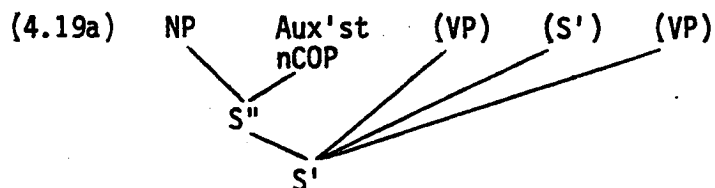
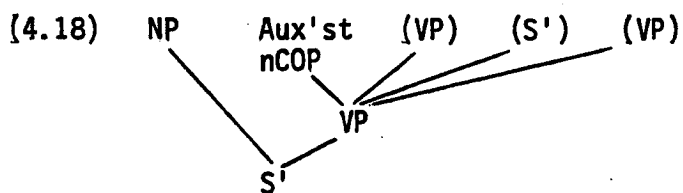
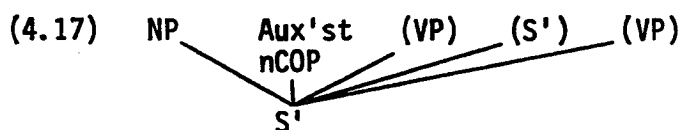

As far as I can see, there is no clear empirical evidence ruling out either (4.18) or (4.19a and b). Of these, (4.18) seems the least

attractive since there is no evidence for an overarching VP node: the Aux stem plus what follows it together never act like a unit with respect to movement or scope of particles as does an individual VP or embedded clause.

Diagram (4.19a) is another option for the structure of a non-copula S'. This is more attractive since a case can be made for a close relationship between the subject and the Aux stem. First, the subject can be a person prefix attached to the Aux stem. Second, nothing can intervene between the subject and the Aux stem; if the subject NP is raised into S (e.g. in WH questions) a third person singular person prefix replaces it, maintaining a subject in front of the Aux stem. Third, in the case of copula sentences as in (4.19b), the analysis with S" suggests a natural reason why a predicate NP can occur immediately after the Aux stem but no farther to the right: there is an S" boundary before the following VPs, etc., which are adjuncts modifying the S". (If (4.17) were a copula S', a NP dominated by S' would follow the Aux stem. If (4.18) were a copula S', a NP dominated by VP would follow the Aux stem.) These arguments are appealing, but they do not seem to me to be strong enough to warrant the increased complexity of adding a S" to the inventory and having three sentence levels even for a minimal sentence consisting of just a NP and an Aux stem.

4.3 VP, S', and S'- \bar{a} Preposing within S'

Within a S' one VP or one S' or one S'- \bar{a} can be foregrounded by preposing it to the front of the S'. In general this limit of preposing only one such item is strictly insisted upon and provides an

excellent operational means of determining the boundaries of these preposable constructions. There are some text examples with more than one VP preposed, however. Some of these involve sentence fragments, but others seem to involve a kind of listing, with comma pause, which supersedes the usual one VP limit:

(4.20)T jâp mâga, bebe-kot sép sâã, eé-ve mâkiî
 arrow make pig-grey hair weave that-pl make-pl.o

téteé bó ôòc sé-e-na kí-nap
 only tz male pSJV+asr-th-lk ev-ndef.tm

'Make arrows, weave caititu hair, make those things is what a man does.'

Quoted utterances marked with -á are complex verbs. If one is preposed no other VP can be preposed. Occasionally this appears to be violated, but in such cases the quote has not been preposed, but rather occurs before the S. In the example below the quote precedes the DemP in the Pre-S:

(4.21)T "e-géré kî-á" eé téét tá-mãã
 2s-exh+go again-s.m then exct 3p-pPST+asr

kac kî-á
 (3c)-involve again-s.m

'"Go again!" they said to him again.'

Cases like (4.21) are not covered in the rules of this paper. What might be termed 'sound effects' occur in Gavião narratives, generally preceding a sentence, but sometimes between sentence fragments. Quotes like those in (4.21) seem to fall into this category of sound effects. Some ideophones also occur as sound effects:

(4.22)T gô sóók eé téét éèt
 ? jump then exct (3s)-pPST+pDEF+pSJV+asr

a-sávât--tẹ̀ kî-nap
 3c-jumping-become ev-ndef.tm

'Sóók! Then he jumped up.'

These are not involved in preposing.

In Gavião certain items can only occur sentence initially, others cannot occur sentence initially, and most are unmarked in this regard. This is represented formally by a three-valued feature, pS.I., nS.I., or uS.I. This governs preposing. The preposing of a VP, S', or S'-á within embedded clauses (S's or S'-ás) is examined immediately below. Following that preposing within matrix clauses (S's) is explained.

In embedded clauses preposing is obligatory if the subject person prefix of the Aux stem is nS.I. This is determined by the sentence functional type of the Aux stem. The person prefixes of prohibitive and exhortative Aux stems are pS.I. (though this is not relevant here since these do not occur in embedded clauses). The prefix of the 'let' Aux stem is uS.I., and the prefixes of all other sentence functional type Aux stems are nS.I. So preposing within embedded clauses is:

- (4.23) (i.) obligatory if the subject is a nS.I. person prefix, and
 (ii.) optional otherwise.

For example, in the embedded S' of example (4.14) above (given as (4.24) below) preposing has obligatorily occurred, but in the embedded S' of sentence (4.13) above (given as (4.25) below) preposing was optional and did not occur:

(4.24) Preposing obligatory:

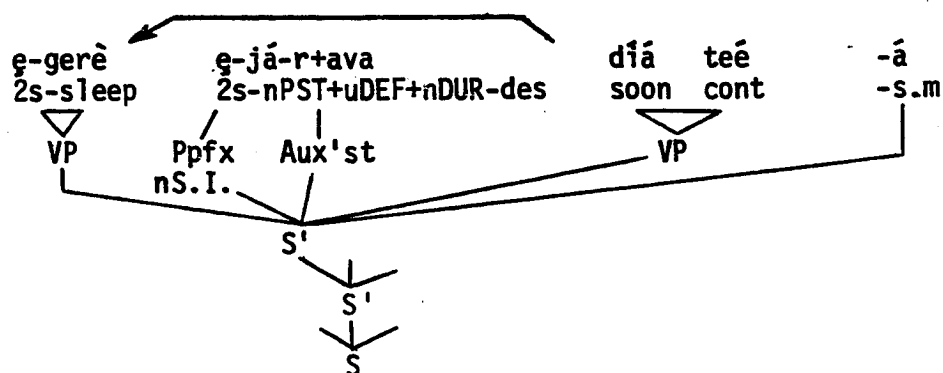

'...it would be good if you sleep..'

(4.25) Preposing optional, did not occur:

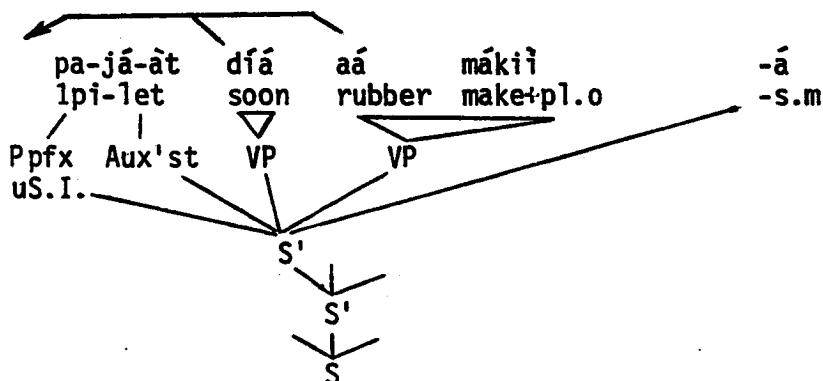

'...to let us make rubber quickly...'

The conditions on preposing within a matrix S' are somewhat different from those on preposing within an embedded S'. One difference is that a nS.I. Aux stem person prefix can be S' initial as long as something else precedes it within the Pre-S.

A second difference is that, so far as is known, preposing is blocked by all pS.I. M.S.E. particles in the Pre-S. There are three M.S.E.s which can occur S initially and which also permit preposing: the two nonparticle M.S.E.s, the sentence-initial demonstrative phrase and the abstract question marker Q; and the uS.I. M.S.E.

particle de...kĩ 'tentative negation'.

A third difference is that preposing within a matrix S' feeds the transformation Preposing into S (discussed in Section 7), which moves a phrase from S'-initial position into S-initial position, obligatorily if necessary to prevent a nS.I. M.S.E. from being S initial. So preposing within a matrix S' must ensure that a phrase is S' initial if only nS.I. M.S.E.s are in the Pre-S.

In summary then, {VP, S', S'-á} preposing within a matrix S' occurs:

- (4.26) (i.) obligatorily if the Pre-S is null and a nS.I. Aux stem person prefix is the subject, or
- (ii.) obligatorily if the Pre-S contains only nS.I. M.S.E.s and the subject is a person prefix, or
- (iii.) optionally if the Pre-S is null and the subject is a NP or uS.I. person prefix, or
- (iv.) optionally if the Pre-S contains DemP, Q, or de...kĩ 'tentative negation'.

The operation of preposing under these conditions is illustrated in diagrams (4.27-4.31) below. The S.I. status of person prefixes and M.S.E.s is indicated:

(4.27)T Preposing obligatory by (4.26.i) since Pre-S is null and the subject is a nS.I. prefix:

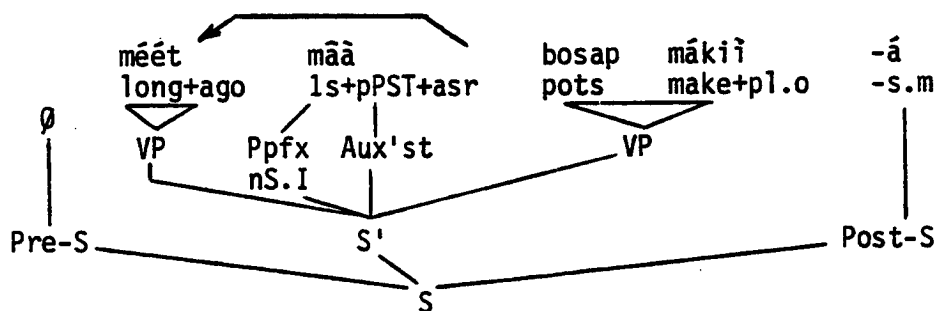

'I made pots long ago.'

(4.28)T Preposing obligatory by (4.26.ii) since Pre-S contains only nS.I. M.S.E.s and the subject is a person prefix. The VP was preposed into S'-initial position, then, by Preposing into S was moved again to S-initial position.

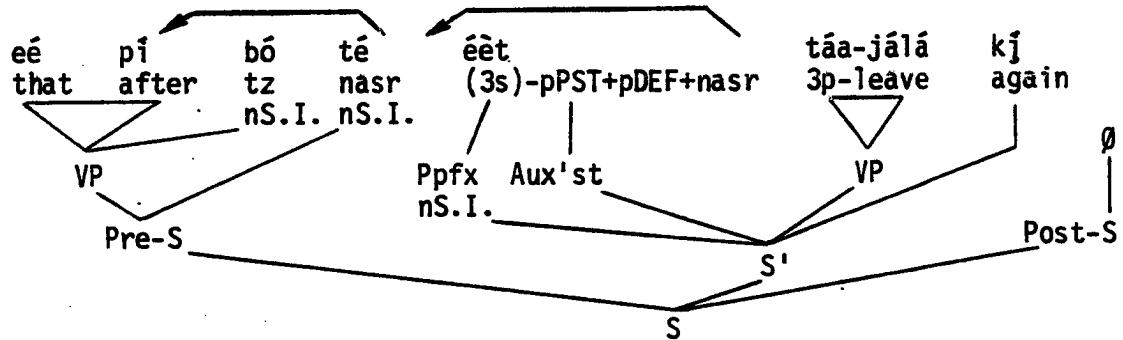

'After that he left them again.'

(4.29)T Preposing optional (but did not occur) by (4.26.iii) since Pre-S is null and the subject is a uS.I. NP:

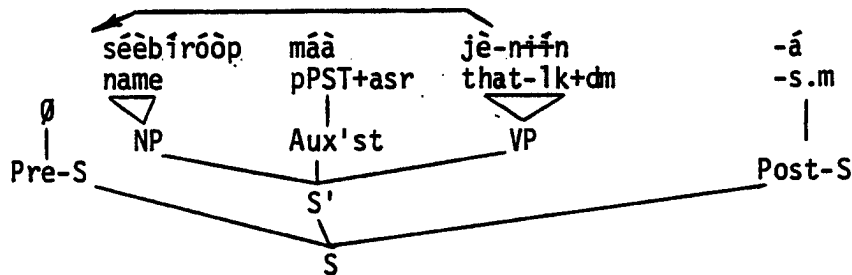

'There's Séèbíróòp like that.'

(4.30)T Preposing optional (and occurred) by (4.26.iv) since DemP occurs in the Pre-S:

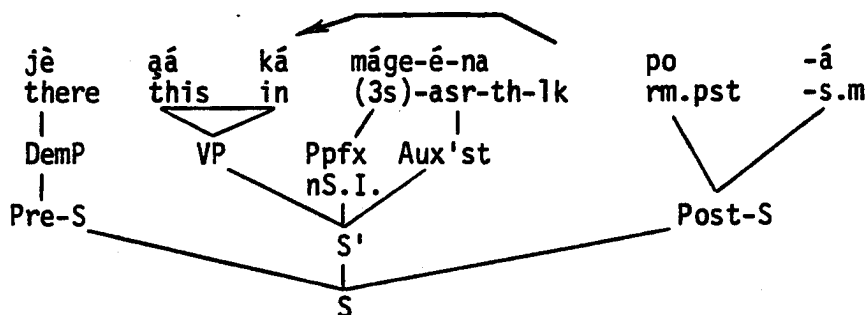

(4.31)T Preposing prohibited since the M.S.E. in the Pre-S does not permit it:

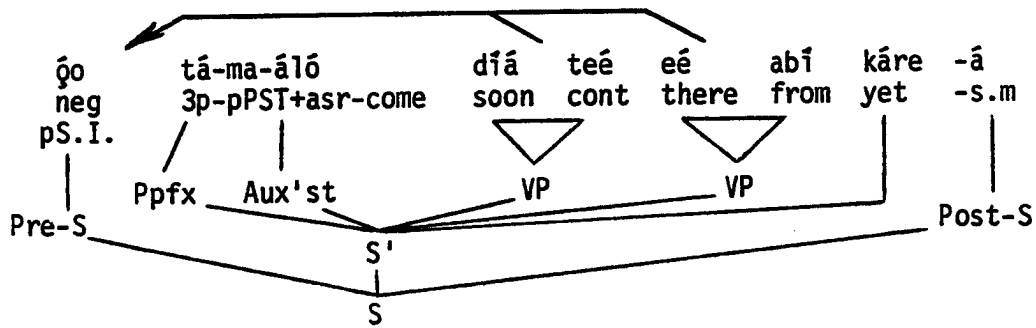

'They didn't return soon from there.'

The rules for preposing a VP, S', or S'-ã within an embedded S' under conditions (4.23.i-ii) and within a matrix S' under conditions (4.26.i-iv) are collapsed into rule (4.32) below:

(4.32) { VP, S', S'-ã } Preposing within S' (first approximation):

$$\left\{ \begin{array}{l} \text{Pre-S} \\ K \end{array} \right\} - \left[\begin{array}{l} W - \text{Aux'st} - X - \left\{ \begin{array}{l} \text{VP} \\ S' \\ S'-\underline{\text{ã}} \end{array} \right\} - Y \end{array} \right]_{S'} - Z$$

$$\begin{array}{ccccccc} 1 & 2 & 3 & 4 & 5 & 6 & 7 \\ 1 & 5 & 2 & 3 & 4 & 6 & 7 \end{array} \Rightarrow$$

Conditions:

- (a.) 5 must be immediately dominated by S'.
- (b.) obligatory:
- (i.) if 1 is K or a null Pre-S and W is just a nS.I. person prefix (conditions (4.23.i) and (4.26.i)), or
- (ii.) if 1 is a Pre-S containing only nS.I. M.S.E.s and W is just a person prefix (condition (4.26.ii))
- (c.) optional:
- (i.) if 1 is K or a null Pre-S and W contains a NP or uS.I. person prefix (conditions (4.23.ii) and (4.26.iii)), or
- (ii.) if 1 is a Pre-S containing DemP, Q, or de...kĩ (condition (4.26.iv))

Application: Applies once to any S' with no order of application.

This rule picks out any VP, S', or S'-a immediately dominated by S' and preposes it to S'-initial position, where it is still dominated by S'. The upper option in position 1 represents a Pre-S which can be null or can contain any string of M.S.E.s. If this option obtains the S' is a matrix S'. In the lower option in position 1, K represents any formatives or boundary symbols which are not contained within a Pre-S. If this option obtains the S' is an embedded S'.

Position 2 is the subject position. The variable string symbols X and Y in 4 and 6, respectively, permit any VP or embedded clause to be selected. The restriction that 5 be immediately dominated by S' is necessary so that only a maximal phrase or embedded clause can be selected, not one of their subparts, which may well be another VP or S' or S'-a.

5.0 COPULA S' COMPOSITION

Copula sentences are much less common in texts than are noncopula sentences, and their analysis is correspondingly less certain. Informant grammaticality judgments about copula sentences are oddly vague and inconsistent. Some examples of copula sentences are given below with the predicate (pred) NP and subject (subj) NP or person prefix underlined:

(5.1)T v̄azet má-pê-e mákî-i té-teé
 female poss-thing-pl make+pl.o-nz only
 pred NP

taác eé-na kí-nap
 3s-(pCOP+pSJV+asr) th-1k ev-ndef.tm
 subj Ppfx

'It's just women's work.'

(5.2)T eé bapi máã
 there guest (3s)-pCOP+asr
 pred NP subj Ppfx

'He was a guest there.'

(5.3)T eé bapi já kí-nap
 there guest (3s)-pCOP+pSJV+asr ev-ndef.tm
 pred NP subj Ppfx

'He was a guest there.'

(5.4)T pa-gó pétãc tóôt té ãá
lpi-mouth crooked attached nasr this (pCOP+nasr)
 pred NP subj NP

'This (one) has a crooked mouth.'

There are four principal differences between copula and noncopula sentences. First, copula sentences always contain a predicate NP, whereas noncopula sentences never do. There appears to be some sort

of restriction on which NP can be the subject NP and which can be the predicate NP. In general the subject NP seems to be more definite. It is not always clear how definite a NP is, and this may be one of the reasons informants give different opinions about the grammaticality of invented copula sentences.

A second difference between copula and noncopula sentences is that the occurrence of VPs in the former is much more restricted than in the latter. In almost all text examples of copula sentences the VPs are semantically adverbial, usually containing postpositional transitive verb stems or time, place, or manner verbs. However, note the following text example with a VP containing a complex cross-refering verb stem (VP underlined):

(5.5)T á-na má-àc té já ǎǎ
 which-1k sb.nz-pl nasr (3s)-pCOP+nasr this

a-bólǎǎ ajóòt--tá-á
 3c-hugging standing+dm-be-s.m

'Who were these standing with their arms around each other?'

So the exact nature of the restriction on which VPs can occur in copula sentences is not clear. This may be a semantic restriction rather than a syntactic one. No embedded clauses occur in the text copula sentences collected, but such occurrence cannot be ruled out.

A third difference between copula and noncopula sentences is that a pCOP Aux stem is always unmarked for tense, aspect, and motion. This is expressed formally as one of the cooccurrence restrictions on Aux stem features (see Section 6.0).

A fourth difference is that certain sentence functional types (imp, proh, exh, sim) cannot be of the copula sentence structural

type. These restrictions are stated in the revised S' composition rule below.

5.1 Copula S' Composition Rule

The S' composition rule (4.15) is revised below so as to include copula as well as noncopula S's:

(5.6) S' Composition (revised):

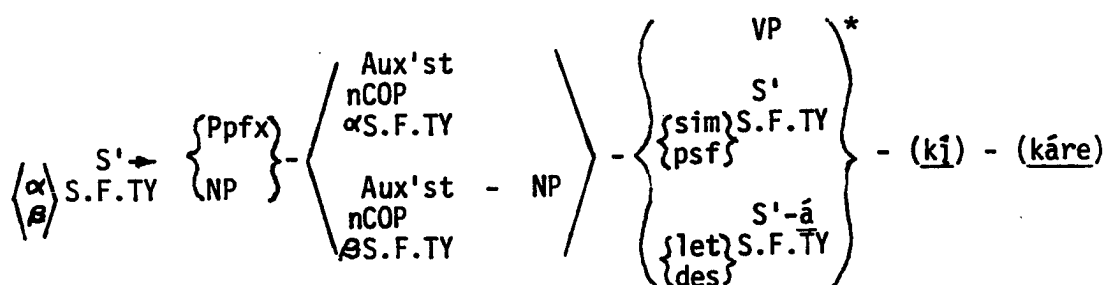

Where α is any S.F.TY value, and
 β is any S.F.TY value except imp, proh, exh, or sim

This rule states that a S' must contain a subject person prefix or NP, followed by a nCOP Aux stem or by a pCOP Aux stem and a predicate NP. The angled bracket notation and the restrictions on β but not on α prevent any imperative, prohibitive, exhortative, or simulfactive S' from containing a pCOP Aux stem or a predicate NP while allowing any sentence functional type S' to contain a nCOP Aux stem. The Aux stem in any case is marked for the same sentence functional type as the S'. Optionally any number of VPs, simulfactive or postfactive S's, or 'let' or desiderative S'-ás can occur in any order. Two aspectual particles can also optionally occur at the end. Rule (5.6) does not attempt to state the restrictions on which VPs, S's, or S'-ás can occur in a copula sentence since these restrictions are

uncertain and may be of a semantic nature.

Notice that rule (5.6) places the predicate NP after the Aux stem, although in examples (5.1) through (5.4) all the predicate NPs in fact precede the subject and Aux stem. Sentence (5.5) is the only text example where the predicate NP follows the Aux stem, though such a sequence is readily approved by informants. In Section 5.3 a NP preposing rule is given which optionally preposes the predicate NP to foreground it. This parallels preposing rule (4.32), which foregrounds VPs, S's, and S'-ás. The opposite procedure, generating the predicate NP initially and then backing it, would be counter to a generality in Gavião that there are preposing processes which foreground parts of the predicate. Furthermore, the scarcity of surface structures with sentence-initial subjects in copula sentences is not surprising since this is equally true in noncopula sentences. Preposing generally occurs when it can, perhaps because the subject usually contains less new information than the predicate and because preposing is often necessary to prevent an Aux stem prefix from being in sentence-initial position.

5.2 Auxiliary Stems in Copula Sentences

As explained in detail in Section 6.0, there are five morphs which occur in the initial position in the Aux stem: //mága//, //mââ//, //sâ//, //yâ//, or //Ø//. Aux stems which are pCOP always have either //mââ//, //yâ//, or //Ø// as their first morph, never //mága// or //sâ//. The pCOP Aux stems differ only with respect to mood and sentence functional type since they are always unmarked for tense, aspect, and direction of motion.

Since the morphs occurring in pCOP Aux stems are phonetically the same as those in nCOP Aux stems, almost all pCOP Aux stems are phonetically indistinguishable from some nCOP Aux stem. There are two exceptions to this: the third person singular and postnominal forms of //∅// differ according to the value of the COP feature of the Aux stem:

(5.7) Third Singular:	Postnominal:
taâc-∅ 3s-(pCOP+nasr)	∅ (pCOP+nasr)
éèt (3s)-nCOP+nasr	éèt nCOP+nasr

These exceptions preserve some contrast in form between copula and noncopula Aux stems, but contrast in sentence structural type is primarily indicated by the obligatory occurrence of a predicate NP in copula sentences.

Table (5.8) below presents all the pCOP auxiliary stems, each prefixed for second person singular. These are listed in the third column, and their phonetically identical nCOP auxiliary stem counterparts are listed farther to the right. The values of the sentence functional type (S.F.TY) and mood (SJV) features of both the pCOP and nCOP auxiliary stems are listed to the left. Tense (PST) and aspect (DEF, DUR) features are always unmarked for pCOP auxiliary stems, and this is noted. The tense and aspect features of the nCOP auxiliary stems are given in the three rightmost columns. Motion is unmarked in all the Aux stems in (5.8). The Aux stems are given in the regular orthography with morpheme boundaries roughly indicated by hyphens. The //∅// morph is indicated though it is not phonetically overt.

(5.8) Copula Aux Stems and their Noncopula Counterparts (all 2s):

S.F.TY	SJV	2s-Aux'st pCOP		2s-Aux'st nCOP	PST	DEF	DUR
asr	n	e-mãã	(All pCOP	e-mãã	p	u	u
asr	p	ɛ-já	are	ɛ-já	p	n	u
asr	p	ɛèt-∅	uPST, uDEF, and	ɛèt-∅	p	p	n
nasr		ɛ-já	uDUR.)	ɛ-já	p	n	u
nasr		ɛèt-∅		ɛèt-∅	p	p	n
let		ɛ-já-ât		ɛ-já-ât	u	u	u
prev		ɛ-já		ɛ-já	u	u	u
des		ɛ-já-r+ava		ɛ-já-r+ava	u	u	n
psf		ɛ-já-bóc		ɛ-já-bóc	p	u	u
nom		ɛ-já-néè		ɛ-já-néè	p	n	u
nom		eé-∅-néè		eé-∅-néè	p	p	n

Only the assertative and nonassertative pCOP Aux stems are attested in texts. However, two informants affirm the existence of the others in (5.8), and these all follow a pattern of having //mãã//, //yã//, or //∅// as the initial Aux stem morph. Informants claim that there is no difference in meaning between pCOP Aux stems with //yã// as the initial segment and those with //∅//, and I have found no clear difference between these in texts.

5.3 Predicate NP Preposing within S'

Predicate NP preposing within S' is very similar to {VP, S', S'-ã} preposing within S'. There are two reasons to think that they are separate rules. First, it is probably the case that both rules can apply once to to the same S'. There are no text examples of this, but

informants approve the following sentence with double preposing:

(5.9)A nã koc zav-ijaàc evíí máà
 that at house-owner name pCOP+asr
 VP pred NP subj NP

'Evi is chief (house owner) there.'

Informants vary in their estimate of the grammaticality of copula sentences containing a preposed VP, but they usually find such sentences better, not worse, if the predicate NP is also preposed. If VPs could not be preposed in copula sentences it would not be possible to ask 'when', 'why', or 'how' copula questions since these involve sentence-initial VPs containing a WH word. Any preposed VP must precede any preposed predicate NP, as in (5.9). The VP can never intervene between the predicate NP and the subject plus Aux stem. This argues for ordering VP and embedded clause preposing after NP preposing.

Secondly, it is probably the case that predicate NP preposing is not governed by sentence-initial matrix S elements, though VP and embedded clause preposing is. There are no text examples of NP preposing when the negative particle ôo is present, but informants accept the preposed predicate NP in (5.10) but not the preposed VP in (5.11):

(5.10)A ôo zav-ijaàc evíí máà
 neg house-owner name pCOP+asr
 pred NP

'Evi isn't the chief.'

(5.11) *ôo a-kerê evíí mága
 neg 3c-sleep name nCOP+asr
 VP

'Evi isn't sleeping.'

If NP preposing within S' is not governed by M.S.E.s, then these need not be mentioned in the formulation of the NP preposing rule. However, non-sentence-initial Aux stem person prefixes must still be prevented from occurring sentence initially. So in a matrix copula S' the predicate NP must be preposed if the Aux stem person prefix is nS.I. and no pS.I. or uS.I. matrix S element is in the Pre-S. Preposing is optional otherwise. Example:

(5.12)T Preposing obligatory since the prefix is nS.I.:

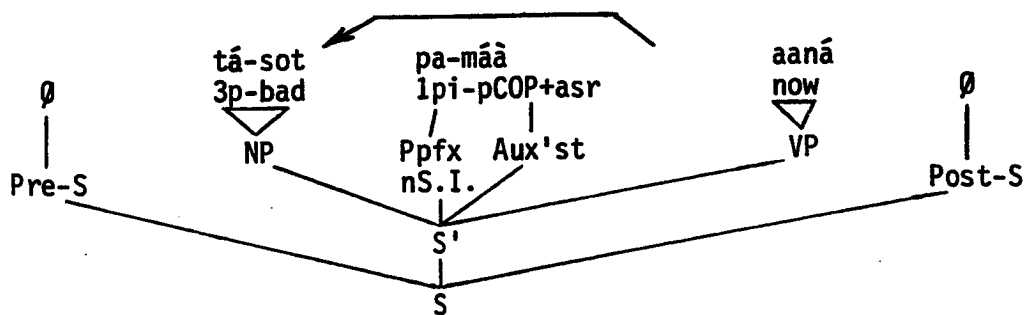

'We're no good now.'

NP preposing is also obligatory if only nS.I. M.S.E.s occur in the Pre-S and the subject is a person prefix since preposing provides a NP in S'-initial position from whence it can be raised into S-initial position in the Pre-S.

Since I have no evidence about predicate NP preposing within embedded S's I shall make the reasonable assumption that it parallels {VP, S', S-a} preposing in such cases: obligatory if there is a nS.I. Aux stem person prefix and optional otherwise.

Transformational rule (5.13) below preposes predicate NPs within S' under the correct set of conditions. It is similar to preposing rule (4.32) above except that in (5.13) no pS.I. M.S.E.s block

preposing, and the rule can 'find' the NP to be preposed by looking immediately after the Aux stem for a NP immediately dominated by S'.

(5.13) Predicate NP Preposing within S' (first approximation):

$$\left. \begin{array}{l} \text{Pre-S} \\ K \end{array} \right\} - \left[\begin{array}{cccccc} W & - & \text{Aux}'\text{st} & - & \text{NP} & - & X \end{array} \right]_{S'} - Y$$

$$\begin{array}{cccccc} 1 & & 2 & 3 & 4 & 5 & 6 \\ 1 & & 4 & 2 & 3 & 5 & 6 \end{array} \Rightarrow$$

Conditions:

- (a.) 4 must be immediately dominated by S'.
- (b.) obligatory:
- (i.) if 1 is K or a null Pre-S, and W is just a nS.I. person prefix, or
- (ii.) if 1 is a Pre-S containing only nS.I. M.S.E.s and W is just a person prefix
- (c.) optional:
- (i.) if 1 is K or a null Pre-S and W is a NP or uS.I. person prefix, or
- (ii.) if 1 is a Pre-S containing a pS.I. M.S.E.

Application: Applies to each S', in any order. Applies before rule (4.32), {VP, S', S'- \bar{a} } Preposing within S'.

Rule (4.32) is stated in such a way that it still functions properly even if rule (5.13) precedes it. However, both rules (4.32) and (5.13) will be revised in Section 7.0 after the interaction of matrix S elements and preposing is discussed.

6.0 SENTENCE FUNCTIONAL TYPES, AUXILIARY STEM FEATURES, AND CLAUSES

General S structure and general S' structure have been described in Sections 2.0, 4.0, and 5.0 above. Specific differences between copula and noncopula S's and between copula and noncopula Aux stems (differences of sentence structural type) were described in Section 5.0. This section explains those properties of clauses (S's) and of Aux stems which are associated with the specific sentence functional type of the clause or Aux stem. In addition to sentence structural type and sentence functional type, a number of other syntactic features occur on auxiliary stems (tense, mood, etc.). These features are characterized and their cooccurrence and expression are examined in this section.

The Aux stem features are syntactic (as opposed to purely semantic) features because they are mentioned by syntactic rules, such as (5.6) S' Composition above or the Auxiliary Stem Feature Composition rule given below. The Aux stem features and their values are considered to be features and values as opposed to morphemes or abstract morphemes because they are quite naturally representable as conceptual dimensions and values on those dimensions and because they do not have biunique, consistent associations with particular segments or positions within the Aux stem. The Gavião category Aux'st does not dominate any other category, as does the corresponding English category Aux. No syntactic rules mention segments or positions within the Gavião Aux'st; its internal composition is its features, which are given phonological form through 'spell-out' rules. Table 6.1 below can be considered a set of spell-out rules assigning each possible set of Aux'st feature values a phonological representation.

(6.1) Noncopula Aux Stems and their Features (all 2s):

S.F.TY	SJV	PST	DEF	DUR	uMOT	goMOT	comeMOT
asr	n	u	u	u	e-mága	e-máa-ka	e-máa-volò
asr	n	p	u	u	e-máà	é-ma-káá	é-ma-áíó
asr	p	u	u	u	ɛ-zá	ɛ-zá-ka	ɛ-zá-volò
asr	p	p	n	u	ɛ-já	ɛ-já-ka	ɛ-já-volò
asr	p	p	p	n	ɛèt-∅	é-∅-ga	é-∅-volò
nasr		u	u	u	ɛ-zá	ɛ-zá-ka	ɛ-zá-volò
nasr		p	n	u	ɛ-já	ɛ-já-ka	ɛ-já-volò
nasr		p	p	n	ɛèt-∅	é-∅-ga	é-∅-volò
imp		n	u	p	ɛ-zá	ɛ-zá-ka	ɛ-zá-volò
imp		n	n	n	ɛ-já	ɛ-já-ka	ɛ-já-volò
imp		n	p	n	ɛèt-∅	é-∅-ga	é-∅-volò
proh		n	u	p	ɛ-zá-(ká)	ɛ-zá-(ká)-ka	ɛ-zá-(ká)-volò
proh		n	n	n	ɛ-já-(ká)	ɛ-já-(ká)-ka	ɛ-já-(ká)-volò
proh		n	p	n	ɛèt-∅	é-∅-ga	é-∅-volò
exh		n	u	u	ɛ-béré	ɛ-géré jaá (lpi, +go)	(no come)
let		u	u	u	ɛ-já-àt	é-∅-gā-àt	é-∅-vol-í
prev		u	u	u	ɛ-já	ɛ-já-ka	ɛ-já-volò
des		u	u	p	ɛ-zá-r+ava	ɛ-zá-kā-r+ava	ɛ-zá-vol-í+va
des		n	u	n	ɛ-já-r+ava	é-∅-gā-r+ava	é-∅-vol-í+va
sim		u	u	u	ɛ-zá-àt	ɛ-zá-kā-àt	ɛ-zá-vol-í
psf		p	u	u	ɛ-já-bóc	é-∅-ga-bóc	é-∅-volò-bóc
nom		u	u	u	ɛ-zá-néè	ɛ-zá-ka-néè	ɛ-zá-volò-néè
nom		p	n	u	ɛ-já-néè	ɛ-já-ka-néè	ɛ-já-volò-néè
nom		p	p	n	eé-∅-néè	é-∅-ga-néè	é-∅-volò-néè

Table (5.8) above listed the pCOP Aux stems. That is, all occurring Aux stem feature combinations which include pCOP were given and the phonological form of each combination was indicated. In similar fashion, table (6.1) above lists the nCOP Aux stems. These are again given in the regular orthography with hyphens roughly indicating morph boundaries, except that the //∅// morph is shown when it occurs. The forms listed are second person singular.

The following prefixed Aux stem contractions (resulting from consonant deletion) occur:

(6.2) pā-àt	<	pa-já-àt 1pi-uPST+uDEF+uDUR+uMOT-1et
té-a	<	té zā nasr 1s+uPST+uDEF+uDEF+nasr+uMOT
té-aká	<	té saká nasr 3s+uPST+uDEF+uDUR+nasr+uMOT
saá	<	saká 3s+uPST+uDEF+uDUR+nasr+uMOT
máa	<	mága uPST+uDEF+uDUR+nSJV+asr+uMOT
pā̄-a	<	pa-mága 1pi-uPST+uDEF+uDUR+nSJV+asr+uMOT
pā̄-à	<	pa-mā̄ 1pi-pPST+uDEF+uDUR+nSJV+asr+uMOT

Throughout this whole section the Aux stem feature values are all indicated, though in other sections unmarked or predictable features are not indicated.

Section 6.1 explains the Aux stem features and their values. Section 6.2 examines the morphs and morph positions in Aux stems and their relationship to the Aux stem features. Section 6.3 characterizes each

of the eleven sentence functional types in turn. The semantic/pragmatic nature of S's of each sentence functional type, the distribution of the S's, the Aux stems with their particular feature values which occur in the S's, and the M.S.E.s which notably cooccur are specified. The inventory and cooccurrence of Aux stem features as given in table (6.1) are attested with examples. Constructions involving embedded clauses (e.g. relative clause equivalents) are discussed in Section 6.3. Section 6.4 explains coreferential anaphora within and across clause boundaries. Lastly, Section 6.5 gives phrase structure and transformational rules which assign feature values to Aux stems and to their person prefixes.

6.1 Features and Values

The eleven sentence functional types are formally indicated by the eleven values of the feature S.F.TY, which occurs on each S, S', Pre-S, Post-S, and Aux stem.

(6.3) Sentence Functional Type:

asrS.F.TY	assertative	prevS.F.TY	preventative
nasrS.F.TY	nonassertative	desS.F.TY	desiderative
impS.F.TY	imperative	simS.F.TY	simulfactive
prohS.F.TY	prohibitive	psfS.F.TY	postfactive
exhS.F.TY	exhortative	nomS.F.TY	nominal
letS.F.TY	'let'		

Each sentence functional type (1) is semantically/pragmatically distinctive from the others, and (2) contrasts with each of them in one or more of the following grammatical matters:

- (1) Aux stem morph composition
- (2) cooccurring Aux stem features
- (3) clause (S') distribution
- (4) cooccurrence of M.S.E.s with Aux stems and with each other
- (5) sentence-initial or non-sentence-initial status of the Aux stem person prefix

The eleven sentence functional type distinctions recognized are the minimal number necessary to account for contrasts in the above.

Most sentence functional types (exhortative, 'let', desiderative, simulfactive, postfactive, and nominal) have distinctive phonological forms of the Aux stem. Auxiliary stems of the prohibitive sentence functional type optionally contain a distinctive segment, -ká, and their person prefixes are sentence initial. The other four sentence functional types are not distinguished by Aux stem form nor by the S.I. value of their person prefixes. Of these four, the imperative sentence functional type is distinguishable from the other three by the fact that Aux stems of this type are always nonpast (nPST) and noncopula (nCOP) and do not appear to cooccur with nonassertative Pre-S particles. The preventative sentence functional type is distinguishable by the fact that Aux stems of this type have no tense or aspect contrasts and S's of this type can occur not only as matrix S's but also as S's nominalized by the particle méne. The nonassertative sentence functional type is distinguished from the assertative sentence functional type in the subjective mood by the obligatory occurrence of nonassertative M.S.E.s in any nonassertative Pre-S.

Only assertative Aux stems have mood in Gavião. An assertative Aux stem may be subjective or nonsubjective, depending on whether

subjective Post-S particles occur:

(6.4) Mood:

pSVJ subjective
nSVJ nonsubjective

Auxiliary stem tense can be past or nonpast. It can also be unmarked for past in the sense that the time reference is neither specifically past nor nonpast and may be timeless, general, or habitual (as in the English sentence, 'Monkeys eat bananas'). Three values for the feature PST account for all tense contrasts in the Aux stems:

(6.5) Tense:

pPST past
nPST nonpast
uPST unmarked for past

Aspect is represented formally by two cooccurring Aux stem features: definite (DEF) and durative (DUR). Each of these may be plus, negative, or unmarked. Aux stems which are pDEF are always nDUR, and those which are pDUR are always uDEF. Other implicational relationships are not simple, but rather depend on the tense and sentence functional type of the Aux stem. The six occurring combinations of aspect feature values are listed below:

(6.6) Aspect:

pDEF, nDUR	definite	uDEF, pDUR	durative
nDEF, uDUR	nondefinite	uDEF, nDUR	nondurative
nDEF, nDUR	nondefinite, nondurative	uDEF, uDUR	unmarked

The Aux stem direction of motion feature, MOT, has three values: go, come, and unmarked (u). If the direction of motion is unmarked on the Aux stem a direction of motion can still be indicated by a motion verb. The three motion possibilities for an Aux stem are:

(6.7) Motion:

goMOT	go
comeMOT	come
uMOT	unmarked

6.2 Auxiliary Stem Segments and Auxiliary Stem Features

The number of morphological segments or morphs which an Aux stem can have depends on its sentence functional type. A maximum of four morphs can occur in desiderative Aux stems; three in prohibitive, 'let', simulfactive, postfactive, and nominal Aux stems; two in assertative, nonassertative, imperative, and preventative Aux stems; and one in exhortative Aux stems.

There are a maximum of four successive Aux stem morph positions. It is not the case that each Aux stem feature or feature value has a biunique, consistent association with a particular morph or position in an Aux stem, but there is a strong tendency for Aux stem morph positions to be associated with (one or more) particular features. The exhortative Aux stems do not follow this general pattern. Otherwise, the first position is associated with tense, aspect, and mood features. The second position is associated with direction of motion, except that in prohibitive Aux stems the third position indicates motion if the optional second position morph -ká occurs. The third position is often associated with sentence functional type indication, but it

may be unfilled or filled by a morph (//*-ãt*//) which by itself does not uniquely specify sentence functional type. The fourth position is only filled in desiderative Aux stems.

This general pattern is illustrated below with Aux stems taken from table (6.1). When sentence functional type is not overtly indicated by a third position morph it is considered, somewhat arbitrarily, to be associated with the initial morph, though not uniquely so.

(6.8)	1	2	3	4	
	sá uPST uDEF uDUR	-kã goMOT	-r desS.F.TY	+ava	sákãrava
	jã pPST nDEF uDUR	-volò comeMOT	-néè nomS.F.TY		jávolònéè
	∅ nPST pDEF nDUR impS.F.TY	-ka goMOT			ka
	mága uPST uDEF uDUR nSJV asrS.F.TY	(uMOT)			mága

In assertative, nonsubjective Aux stems there are two contrasting initial position morphs, which differ only in tense: //mága// (uPST) and //mãã// (pPST). Elsewhere (except in the exhortative Aux stems) there are three contrasting initial position morphs which can occur: //sã//, //yã// (usually jã), and //∅//. The tense and aspect features associated with these three morphs vary according to the sentence

functional type of the Aux stem.

For example, an imperative Aux stem must have a nPST tense, and so in imperatives the three segments contrast only with respect to aspect. However in a nominal Aux stem the three morphs contrast both in tense and aspect. In the case of a 'let' Aux stem, only the //yá// morph occurs when direction of motion is unmarked, and there are no tense or aspect contrasts. When direction of motion is indicated the //yá// morph does not occur in the first stem position; the morph //∅// does, and there are still no tense or aspect contrasts. The point is that there are not fixed tense and aspect feature values associated with the morphs //sá//, //yá//, or //∅//. Rather they divide up the available semantic space.

When //∅// is the first position morph and there are no succeeding morphs, there is no overt Aux stem at all. In this case an allomorph of the person prefix occurs which, with two exceptions, is phonetically identical to the corresponding free pronoun. In (6.9) below free pronouns are compared with prefixed Aux stems whose initial morph is //∅//. The Aux stem illustrated is pPST, pDEF, nDUR and nasrS.F.TY.

(6.9) Person	Free Pronoun	Ppfx-Aux'st (uMOT)	Ppfx-Aux'st (goMOT)
1s	qòt	qòt-∅	q̄-∅-ga
2s	eèt	eèt-∅	é-∅-ga
3s	jì, taàc	∅-éèt (nCOP) taàc-∅ (pCOP)	∅-∅-ka
1pi	panóóc	panóóc-∅	pa-∅-ga
1pe	tqóc	tqóc-∅	tó-∅-ka
2p	menóóc	mééc-∅	mééc-∅-ka
3p	tqác	tqác-∅	tá-∅-ka

In (6.9) the third person singular prefix which is a zero morph is also represented by //∅//. The two prefixed Aux stems which differ from free pronouns (∅-êèt instead of taàc, mééc-∅ instead of menóóc) support the analysis that the forms listed in the third column are person prefixes, not free pronouns. In the fourth column mééc is clearly a person prefix in mééc-∅-ka, paralleling the other person prefixes in the column. This supports the claim that the forms in the third column are person prefixes since these parallel mééc phonologically in that they end in long closed syllables.

When free pronouns occur instead of person prefixes in Gavião the person is emphasized. The forms in the second column do not emphasize person, which further supports the claim that they are prefixes. Question example showing free pronoun subject used to emphasize person:

(6.10)T té êèt sé-e-na ǵá sep
 (Q) nasr you uPST+uDEF+uDUR+uMOT+nasr-th-lk this lf.o
 ma'ǵ kí-nāā
 take ev-prox.tm

'Is it you that's going to take this photo?'

Direction of motion is generally indicated in the second position of the Aux stem. No segment occurs if the direction of motion is unmarked. Otherwise (except for the exhortative Aux stems) there are two segments always associated with go or come MOT values:

(6.11) // -ka// goMOT
 // -vo1// comeMOT

In the third and fourth positions the 'let', desiderative, simulative, postfactive, and nominal sentence functional type Aux stems

have overt morphs indicating sentence functional type:

(6.12)	//-àt//	letS.F.TY
	//-àt+ava//	desS.F.TY
	//-àt//	simS.F.TY
	//-bôy//	psfS.F.TY
	//-néè//	nomS:F.TY

Of these, it is not possible to assign a constant meaning to // -àt//. Contrast is maintained between let and sim since sim occurs only with the initial position morph //sá//, but let never does. The feature value des is indicated by two segments. These are considered two morphs composing one morpheme and are joined with a plus sign.

The suffix // -eé-na// 'thus, like that' commonly occurs on Aux stems as well as on verb stems and verbs. This seems to often be used to indicate action in progress.

6.3 Sentence Functional Types

Each of the eleven sentence functional types is discussed in turn below.

6.3.1 Assertative Clauses and Auxiliary Stems

Assertative S's are dominated only by Ss. That is, they are only matrix S's, not embedded S's. They assert something to be the case, contrasting with the more tentative nonassertative S's. A subset of the time particles (po and nââ+po) and a subset of the time particles (kí-po, kí-nâ+po, kí-nap, and kí-ip) occur only in assertative sentences.

In the nonsubjective mood the first position Aux stem morphs are

//māga// (uPST, uDEF, uDUR) and //māã// (pPST, uDEF, uDUR):

(6.13)T gô-e mi māge-é-na
 1s+word-pl use 1s+uPST+uDEF+uDUR+nSJV+asr+uMOT-th-1k

ma-kôbāã
 (3s)-tr-learn

'I'm teaching him (by) speaking my language.'

(6.14)T eé pí māã za-vípi
 that from 1s+pPST+uDEF+uDUR+nSJV+asr+uMOT w+house-wall

pogô-ã
 cover-s.m

'Then I covered the walls.'

The subjective mood occurs only when time-of-evidence particles or 'think' particles occur in the Post-S node. The first position stem morph //sã// indicates uPST, uDEF, and uDUR:

(6.15)T eé bó ní zã
 then tz ? 1s+uPST+uDEF+uDUR+pSJV+asr+uMOT

déer-íft mi māga ále nó
 bigger-ish+dm use (3s)-make fut opinion

'Then I think I'll make bigger (ones).'

The stem initial morph //yã// indicates pPST, nDEF, and uDUR. That is, the action occurred in the past, its point of inception is indefinite, and it may have continued over a period of time or not. In the example below the action had little duration:

(6.16)T eé bó já-ke-é-na
 then tz (3s)-pPST+nDEF+uDUR+pSJV+asr-go-th-1k

táãc-tíîr-ê-na eé koj-é-na kí-ñap
 3p-with+dm-th-1k that at-th-1k ev-ndef.tm

'Then he went there with them.'

The stem initial morph //Ø// indicates pPST, pDEF, and nDUR
(gloss underlined):

(6.17)T māt ákini bō ci-sano ka
that see tz 3s-brother (pPST+pDEF+nDUR+pSJV+asr)-go

kí-nap
ev-ndef.tm

'His brother went to see him.'

The mood contrast in the assertative sentences is designated plus or negative subjective instead of plus or negative subjunctive in part because the sentences are not subjoined in the usual sense, but also because there appears to be a trace of a true subjunctive. According to informants this subjunctive is generally in disuse in the Gavião dialect. Only one example is available; note the WH demonstrative used in its 'whichever' sense:

(6.18)T "'eeroo, ā koc ō-bag-éèc sáli té
lament whichever at 1s-offspring-pl subjunctive nasr

zā aá-na ō-bag-éèc kalà-á,
1s+uPST+uDEF+uDUR+nasr+uMOT this-1k 1s-offspring-pl miss-s.m

eeroo, eeroo, ' alóp máà-á" kí-ip
lament lament he pPST+uDEF+uDUR+nSJV+asr+uMOT-s.m ev-rc1

'"Eeroo, wherever they may be, I'm lonesome for my sons, eeroo, eeroo,"
he said.'

6.3.2 Nonassertative Clauses and Auxiliary Stems

Nonassertative S's are immediately dominated by Ss. They are questions or tentative statements. Statements using the impossibility particle, kíri...kí, are an exception to this in that they seem quite definite. A subset of the time particles (bō and nāà) and a subset of the time-of-evidence particles (kí-bō, kí-nāà, and kí-ná) occur with

nonassertative sentences but not with assertative sentences. All nonassertative sentences contain one M.S.E. from the set of Pre-S M.S.E.s which can occur when the Pre-S node is nasr (e.g. pazókáde ...kí 'maybe').

Since the nonassertative Aux stems are phonetically indistinguishable from subjective, assertative Aux stems and have the same tense and aspect feature values, it could be maintained that nonassertative Aux stems (and others) also have subjective mood. However, there are mood contrasts only in assertative Aux stems, so only assertative Aux stems are considered to have mood in order to avoid unnecessary proliferation of features. The nonassertative Aux stem features for tense and aspect are illustrated below:

(6.19)T ibalê-e mága té alé-ec sá
 dance-nz make nasr 3s-pl uPST+uDEF+uDUR+nasr+uMOT

kí-ná-á
 ev-ndef.tm-s.m

'They are making a dance.' (statement seeking confirmation)

(6.20)T té pagĩñ-éèc já ve-mi
 (Q) nasr Zoró-pl pPST+nDEF+uDUR+nasr+uMOT it-use (=well)

mákiĩ-á ñaác
 (3s)-make+pl.o-s.m intro+topic

'Did the Zoró make (them) well?' (question)

(6.21)T eé bó té é-ga iiv-áap
 then tz nasr 2s-(pPST+pDEF+nDUR+nasr)-go wood-holw.o

tára
 atop

'Then you went into the canoe.' (statement repeating other's statement)

Rarely, a nonassertative Aux stem has tense and aspect features like those of the corresponding imperative Aux stem. This appears to be a function of which Pre-S particle is used. Note that in the following example tense is nPST and aspect is nDEF, nDUR:

- (6.22)T "'á-de pa-já-ka
 which-nasr.tz (=perhaps) 1pi-nPST+nDEF+nDUR+nasr-go
- cí-kinĩ matéé é-gac káre-á' máã
 3s-see cause 2s-involve yet-s.m (3s)-pPST+uDEF+uDUR+nSJV+asr+uMOT
- kaj-á" kí-ip
 (3s)-involve-s.m ev-rcl
- '"Maybe we'll go let you see," he said to him.'

6.3.3 Imperative Clauses and Auxiliary Stems

Pragmatically, imperative sentences order that something be done. An imperative S' is always dominated by a S. At least some Pre-S and Post-S particles can occur in imperative sentences, but exactly which ones has not been determined.

All imperative Aux stems have nPST tense. There are three aspect contrasts. When //sá// is the initial Aux stem morph the imperative Aux stem is uDEF and pDUR in aspect. The action is to be taken on a continual basis:

- (6.23)T tó-vít aka e-zá táá-bep
 1pe-food kill 2s-nPST+uDEF+pDUR+imp+uMOT 3p-time+after
- ká ále-á, dééni
 in fut-s.m name

'Hunt for us while they're gone, Denny.'

The Aux stem initial morph //yá// indicates nDEF, nDUR aspect. The action is to be taken at some time in the future, usually not

immediately. The future particle ále is obligatory with //yá//, though this is not formalized in the rules of this paper.

(6.24)T e-volô e-já ále-á
2s-come 2s-nPST+nDEF+nDUR+imp+uMOT fut-s.m

'Come.' (order to appear for a soccer game sometime soon)

When the morph in initial Aux stem position is //ø//, the aspect is pDEF, nDUR. The action is to be carried out at some definite point in time, possibly immediately:

(6.25)T vása aka é-ga-á
tapir kill 2s-(nPST+pDEF+nDUR+imp)-go-s.m

'Go kill a tapir!' (joking command for immediate action)

All imperative Aux stem examples at hand have second person prefixes, but this limit is not firmly established.

6.3.4 Prohibitive Clauses and Auxiliary Stems

Pragmatically, prohibitive sentences order that something not be done. Prohibitive S's are always dominated by Ss. The prefixed Aux stem always occurs in sentence-initial position, so no Pre-S M.S.E.s can occur. All text examples have second person prefixes. There is an optional morph, -ká, of uncertain, if any, meaning which can occur after //sá// or //yá//, though it need not. Tense is always nPST and the aspect contrasts are the same as those for the imperatives.

(6.26)T e-zá-ká má ivííí teé ále-á
2s-nPST+uDEF+pDUR-proh+uMOT other leave+dm cont fut-s.m

'Don't leave anything there.' (Cinta Larga dialect)

(6.27)T "me-já-ká paágá kîî teé
 2p-nPST+nDEF+nDUR-proh+uMOT (3s)-open ints cont
 mee-kaâ-p koc kâra-âle-â" mää
 2p-go-nz at yet-fut-s.m (3s)-pPST+uDEF+uDUR+nSJV+asr+uMOT
 tá-kaj-â
 3p-involve-s.m

'Don't open it on your trip,' he said to them.' (order not to do something at some indefinite time)

(6.28)A eèt e-gerè díá teé-â
 2s-(nPST+pDEF+nDUR+proh+uMOT) 2s-sleep soon cont-s.m

'Don't sleep soon.'

6.3.5 Exhortative Clauses and Auxiliary Stems

Exhortative sentences exhort the subject to do the action specified. Exhortative S's are always dominated by Ss. The exhortative Aux stem prefix is always sentence initial. The tense is nPST and the aspect is considered to be uDEF and uDUR since there are no contrasts. The direction of motion feature may be unmarked or may have the value go, but not the value come. The exhortative Aux stems are morphologically different from other stems:

(6.29) //-péré// nPST+uDEF+uDUR+exh+uMOT
 //-kéré// nPST+uDEF+uDUR+exh+go
 //yaá// 1pi+nPST+uDEF+uDUR+exh+go

Of the above three, the first two occur only with second person prefixes. The third, jaá, takes no person prefixes, being inherently first person plural inclusive. There is no first person plural inclusive exhortative Aux stem unmarked for motion; the 'let' Aux stem is used for this. Exhortative examples:

(6.30)T dééni! e-béré má cip
 name 2s-nPST+uDEF+uDUR+exh+uMOT other lf.o+dm

ma-'-ólóòr-á
 tr-come+dm-s.m

'Denny! Give (us) another photo!'

(6.31)T jaá paa-gaà-á
lpi+nPST+uDEF+uDUR+exh+go lpi-go-s.m

'Let's go!'

6.3.6 'Let' Clauses and Auxiliary Stems

A 'let' S' may be immediately dominated by a S or it may be marked with -á and embedded as a S'-á dominated by another S'. In either case the Aux stem prefix can be either sentence initial or noninitial. The Aux stem initial position morph is //yá// when direction of motion is unmarked and //Ø// when motion is go or come. The tense is debatable. Since there are no tense contrasts and since it seems possible for a 'let' sentence to indicate a timeless condition, the tense will be considered uPST. Aspect is uDEF and uDUR since there are no contrasts.

Pragmatically, when a 'let' S' is dominated by S it orders the hearers to allow the subject to perform or undergo the specified action:

(6.32)T alóp aka bó pá-àr-á
 him kill tz lpi+uPST+uDEF+uDUR+uMOT-let-s.m

'Let's kill him.'

(6.33)T vā-àt táá-kinì káre
1s+uPST+uDEF+uDUR+uMOT-let 3p-see yet

'Let me see them.'

When no VPs are present in the sentence the hearer is ordered to let the subject be:

(6.34)T já-àt káre-á
(3s)-uPST+uDEF+uDUR+uMOT-let yet-s.m

'Let him be.' (Don't disturb the cat.)

When a 'let' S'-á is embedded in another S', the meaning is (roughly) that the higher S' subject is doing the higher S' predicate letting the S'-á subject do the S'-á predicate, e.g.:

(6.35)T aáv-á. pa-já-àt díá aá
yes-s.m lpi-uPST+uDEF+uDUR+uMOT-let soon rubber
S'-á

mákiï-á pa-máa-ka eé koc teé
make+pl.o-s.m lpi-uPST+uDEF+uDUR+nSJV+asr-go that at cont

veérép teé kǎ ále
together cont again fut

'Yes. To make rubber quickly we'll go there together again.'

The embedded S'-á in sentences such as (6.35) are not -á-embedded quotes/thoughts of the subject of the higher S' since, (1) the Aux stem person prefix in the S'-á must be marked with the coreferential person prefix //a-// if it is third person and coreferential with the subject of the higher S' subject, and (2) the subject of the higher S' can be inanimate, e.g.:

(6.36)A gǎóc mi mát mága
ground use sb.nz uPST+uDEF+uDUR+nSJV+asr+uMOT
inanimate subject

a-vêre--tá díá pa-já-àt pa-volô díá-á aá
3c-going-be soon lpi-uPST+uDEF+uDUR+uMOT-let lpi-come soon-s.m s.m
S'-á

'The bus is going fast so we will arrive soon.'

6.3.7 Preventative Clauses and Auxiliary Stems

Preventative S's can be dominated by Ss, or they can be marked with -á and nominalized with the nonsubstantive nominalization particle, méne. In the latter case the resulting construction is a complex noun (N) and must be the object of the postpositional transitive verb stem kā 'be in, because'. In either case the Aux stem person prefix is never sentence initial. The Aux stem initial position morph is //yá//. There are no tense or aspect contrasts. As in the case of the 'let' sentence functional type, tense is considered uPST and aspect is considered to be uDEF, uDUR.

When a preventative S' is dominated by S it orders the hearers to prevent the subject from doing or undergoing the action specified:

(6.37)T tó-sérék já a-vé-palā
 1pe-clothes uPST+uDEF+uDUR+prev+uMOT 3c-intr-rip

tó-men-éèc ábep ká-á
 1pe-husband-pl time+after in-s.m

'Don't let our clothes get ripped while our husbands are gone.'

Unlike a 'let' S'-á, a preventative S'-á cannot be immediately dominated by a S'. It occurs instead only in constructions with the structure diagrammed below:

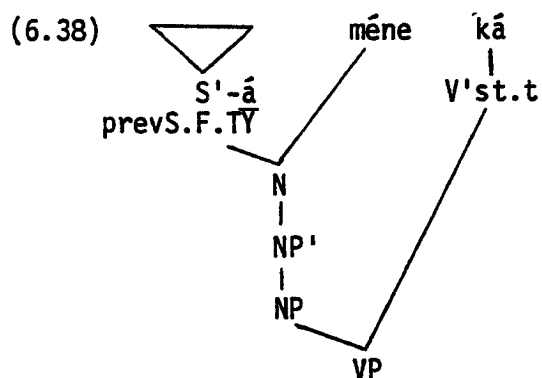

The meaning in such cases is that the higher S' subject is doing the higher S' predicate in order to not let the subject of the S'-á do or undergo the S'-á predicate. Example:

(6.39)A pa-vít va e-já díá teé-á
 lpi-food eat 2s-uPST+uDEF+uDUR+prev+uMOT soon cont-s.m
 S'-á

méne ká mága pa-vít
 nsb.nz in (because) 1s+uPST+uDEF+uDUR+nSJV+asr+uMOT lpi-food

tá-á
 with-s.m

'I'm keeping our food so you won't eat it soon.'

6.3.8 Desiderative Clauses and Auxiliary Stems

A desiderative S' may be a matrix S' immediately dominated by a S or may be marked with -á and embedded as a S'-á dominated by another S'. In either case the Aux stem person prefix is never sentence initial. There are two tense and two aspect contrasts. Desiderative Aux stems with //sá// in the initial stem position are uPST, uDEF, and pDUR. Contrasting with these are desiderative Aux stems with //yá// in initial stem position when motion is unmarked and //∅// in initial stem position when motion is go or come. Such Aux stems have nPST tense and uDEF, nDUR aspect.

A desiderative S' dominated by S states that the speaker thinks it desirable that the subject perform or undergo the action. A durative example:

(6.40)A gakoráá e-zá-ká-r+ava
 hunt 2s-uPST+uDEF+pDUR-go-des

'You should go hunt.' (habitually)

A nondurative example:

(6.41)T ñã sep cólóc ákinĩ pa-á-r+ava
 those lf.o long+pl+dm see lpi-nPST+uDEF+nDUR+uMOT-des

'It would be good if we looked at those long photos.'

When a desiderative S' is embedded as a S'-á dominated by a higher S' the meaning is that the subject of the higher S' thinks it would be good if the subject of the lower S'-á performed or underwent the action of the lower S'-á:

(6.42)A e-gerê e-já-r+ava díã teé-á
 2s-sleep 2s-nPST+uDEF+nDUR+uMOT-des soon cont-s.m
 desiderative S'-á

mãã é-gaj-á
 1s+pPST+uDEF+uDUR+nSJV+asr+uMOT 2s-involve-s.m

'I wanted you to sleep soon.'

The Aux stem person prefix in the S'-á must be marked for co-referentiality if it is third person and coreferential with the higher subject. Possibly the higher subject can be inanimate, unlike the subject in (6.42), but this is not established.

6.3.9 Simulfactive Clauses and Auxiliary Stems

Simulfactive S's are always embedded clauses dominated by S's. The sim S.F.TY value indicates that the event specified by the higher S' occurs simultaneously with the event specified by the embedded simulfactive S'. The simulfactive Aux stem initial position morph is always //sá// and there are no tense or aspect contrasts. Tense is relative to the time of the higher S', not to the time of the utterance. It is considered uPST since a simulfactive clause could describe

(6.45)T eé bó tá-mága aa-ja-ji
 then tz 3p-uPST+uDEF+uDUR+nSJV+asr+uMOT 3c-face-enter
 post-
 a-já-bóc ê-abí a-volò-á
 (=grow) 3c-pPST+uDEF+uDUR+uMOT-psf that-after 3c-come-s.m
 factive S'

'Then they will arrive from there when they have already grown up.'
 (The boys hunting the Giant Lizard return as adults.)

(6.46)T má aka té jĩ-ĩc já
 other kill nasr 3s-pl pPST+nDEF+uDUR+nasr+uMOT
 vê-'-igí vā-bóc a-pi
 1s+intr-remove 1s+pPST+uDEF+uDUR+uMOT-psf 3c-from
 postfactive S'

'They killed the other (person) after I left them.' (Cinta Larga
 dialect)

6.3.11 Nominal Clauses and Auxiliary Stems, Relative Clause and Sentence Complement Equivalents

A nominal S' is never immediately dominated by a S' or S. Instead it is obligatorily nominalized with the substantive nominalization particle mát or the nonsubstantive nominalization particle méne. The resulting construction is a complex noun (N) and distributes like any other complex noun. It translates as a relative clause or sentence complement. Structural diagram:

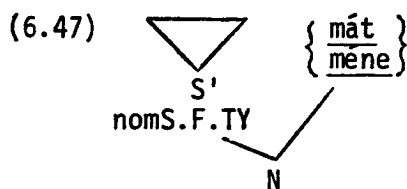

All three contrasting Aux stem initial position morphs occur in nominal Aux stems. Their tense and aspect indication is the same as in the corresponding nonassertative Aux stems: //sá//, uPST, uDEF, and

uDUR; //yá//, pPST, nDEF, and uDUR; //Ø//, pPST, pDEF, and nDUR. The Aux stem person prefix is never sentence initial. It must be marked for coreferentiality if it is third person and coreferential with the subject of the higher S' which contains it.

Example with //sá//, nominalized clause as subject N:

(6.49)T pa-bábe ákinì, mága òòp saká-nèè
 lpi-hands see (3s)-make neg 3s+uPST+uDEF+uDUR+uMOT-nom
nominal S'

mát sé-e-na a-ma-kóbáá kí-nap
 sb.nz uPST+uDEF+uDUR+pSJV+asr+uMOT-th-1k 3c-tr-learn ev-ndef.tm

'She who doesn't make (pots) teaches herself watching our hands.'

Example with //yá//, nominalized clause as possessor N:

(6.50)T "eé téét majóp ijaàc ná paderè já-nèè
 then exct claypit owner vz person pPST+nDEF+uDUR+uMOT
nominal S'

-nom mát má-'-ii ólopaà pavé-èc máà
 sb.nz poss-chicha eat+up creature-pl pPST+uDEF+uDUR+nSJV+asr
 +uMOT kíi kíriñáá kíi-á" kí-po-á zāno-'-éèj-á
 ints all ints-s.m ev-rm.pst-s.m 1s+brother-pl-s.m

'Then the creatures were eating up all the chicha of the person who was the owner of the claypit, my brothers.'

Example with //Ø//, nominalized clause as direct object N, modified by adjective:

(6.51)T "eé bó pazé-èc máà sóp
 then tz other-pl pPST+uDEF+uDUR+nSJV+asr+uMOT claypit

abí palí sábeè ánéè a-vé-pea
 beside pachiuba board (pPST+pDEF+nDUR+uMOT)-nom 3c-intr-beat+pl.o
nominal S'

mát picaá mága-á" kí-ip
 sb.nz standing+pl put-s.m ev-rcl

'Then the others put beaten pachiuba boards beside the claypit.'

The above examples (6.49-51) use the substantive nominalization particle, mát, and translate as relative clauses. The head of the relative clause is the subject of the nominal S' in these three examples, but a direct object (underlined below) can also be the head:

(6.52)T até qá sérék tá zâ-néè
 aff this clothing with 1s+uPST+uDEF+uDUR+uMOT-nom
 nominal S'

mát sérék sá kâre kí-nap
 sb.nz clothing uPST+uDEF+uDUR+pSJV+asr+uMOT yet ev-ndef.tm

'This clothing that I'm wearing (in the photo) is still around.'

Notice that the nominalized clause in (6.52) modifies a noun stem (sérék) which is also found in the direct object NP of the clause. This disambiguates whether the subject or direct object is the head of the relative clause.

In sentences (6.49-52) the nominal S' is nominalized with the particle mát. When it is nominalized instead with the nonsubstantive nominalization particle, méne, the resulting construction translates in general as a sentence complement--an action or event described by the S' with no special prominence accorded to a head subject or object. There are no text examples of nominal clauses nominalized with méne which modify a following noun stem identical to a noun stem within the clause (as in (6.52) above), though there is no indication that this cannot happen. Justification for considering nominalizations with mát and méne to be complex nouns is given in Section 12.0, Complex Words and Word Stems. Examples with méne are given below.

Nominalized clause as N which is the argument of a following

noun stem.

(6.53)T o-volò oó-nèè méne ábep
 1s-come 1s-(pPST+pDEF+nDUR+uMOT)-nom nsb.nz time+after
nominal S'

koc téteé bó jî-ïc mää jè má
 at only tz 3s-pl pPST+uDEF+uDUR+nSJV+asr+uMOT that other

aka a-pi po
 kill 3c-from rm.pst

'Only after my departure did they kill that other (one) of them.'
 (Cinta Larga dialect)

Nominalized clause as object of postpositional transitive verb

stem:

(6.54)T "náapó tigi paá-nèè náapó
 that time+of 1pi-(pPST+pDEF+nDUR+uMOT)-nom that
nominal S'

kávo ká méne mi teé pa-máge-é-na
year in nsb.nz use cont 1pi-uPST+uDEF+uDUR+nSBJ+asr+uMOT-th-1k

ibale-é-na kî-á" mää
 dance-th-1k again-s.m 1s+uPST+uDEF+uDUR+nSBJ+asr+uMOT

'I say we're going to dance again the way we did back then last year.'

Nominalized clause as object of postpositional transitive verb

stem:

(6.55)T "eé bó alóp ma-káá boorâar-éèc
 then tz he pPST+uDEF+uDUR+nSJV+asr-go tree+name-pl

kalà eé-na aá-nèè a-vit aka ôòp méne
 want th-1k 3c-(pPST+pDEF+nDUR+uMOT)-nom 3c-food kill neg nsb.nz
nominal S'

ká-á" kî-ip
 in (=because)-s.m ev-rc1

'Then he went to look for the Boorâât Folk because he wasn't getting any game.'

6.4 Coreferential Anaphora Within and Across Clause Boundaries

Only third person prefixes contrast in coreferentiality. The prefix //a-// (unmarked for number) indicates coreferentiality with a S' subject. The other third person prefixes, //si-//, //sa-//, and //∅// (base allomorphs of the third person singular prefix), and //tā-// (third person plural), indicate noncoreferentiality. The examples (6.56.i-iv) below illustrate this contrast. The person prefixes are in NPs or in transitive VPs and are coreferential or noncoreferential with the subject of the clause which immediately dominates the phrase. The dotted line connects coreferential items.

(6.56) Nominal stem and transitive verbal stem person prefix
coreferentiality within clause boundaries:

(i.) $\overbrace{\text{a-sap}}^{\text{-----}}$ koc zāno mága aa-kaā
3c-house to 1s+bro uPST+uDEF+uDUR+nSJV+asr+uMOT 3c-go

'My brother goes to his own house.'

(ii.) $\overbrace{\text{ci-sap}}^{\text{-----}}$ koc zāno mága aa-kaā
3s-house

'My brother goes to his (other person's) house.'

(iii.) $\overbrace{\text{aa-kinĩ}}^{\text{-----}}$ tó-men-êèc mága
3c-see 1pe-husband-pl uPST+uDEF+uDUR+nSJV+asr+uMOT

'Our husbands see themselves (or each other).'

(iv.) $\overbrace{\text{tāā-kinĩ}}^{\text{-----}}$ tó-men-êèc mága
3p-see

'Our husbands see them (other people).'

The third person prefixes of auxiliary stems in embedded clauses also show this coreferential/noncoreferential contrast, indicating

whether the third person subject of the embedded clause is coreferential with the subject of the higher clause:

(6.57)T "eé-na tá-máã a-ma-ágãã,
 th-1k 3p-pPST+uDEF+uDUR+nSJV+asr+uMOT 3c-tr-in+morning
 a-kapãp ma-'-íí áá-néè méne
 3c-darkness tr-enter 3c-(pPST+pDEF+nDUR+uMOT)-nom nsb.nz
 nominal S'

kã-á" kí-ip
 in-s.m ev-rc1

'Like that they made (it) become daylight, when they put back darkness (into the container).'

The coreferential/noncoreferential contrast in nominal stem, transitive verb stem, and auxiliary stem third person prefixes differs from the cross-reference displayed in the cross-referencing verb stem person prefixes. First, the cross-referencing person prefixes show agreement in all persons, singular and plural, not just in third person. Second, a cross-referencing person prefix agrees in person and number only with the subject of the smallest clause which contains it; it never shows agreement across clause boundaries.

By contrast, nominal stem and transitive verb stem third person prefixes in an embedded clause can indicate coreferentiality with the subject of a clause which dominates the embedded clause. In the following example notice that the jaguar is not killing itself--the aa- prefix indicates coreferentiality, not reflexivity:

(6.58)A nekó vol-í+va aa-ka vã-ãr-á
 cat (nPST+uDEF+nDUR)-come-des 3c-kill 1s+uPST+uDEF+uDUR
 'let' S'-ã
 áá
 +uMOT-let-s.m s.m

'I want a jaguar to come for me to kill.'

Now, if a subordinate clause containing a nominal stem or transitive verb stem third person coreferential prefix (//a-//) is dominated by a superordinate clause and the subjects of both clauses are NPs or third person prefixes, then it is syntactically ambiguous whether the //a-// prefix is coreferential with the subject of the subordinate clause or with the subject of the superordinate clause. In (6.59) below the underlined transitive verb stem person prefix is coreferential with the subordinate clause subject:

(6.59)T ãã sãno pĩra mã-àc abiĩ mãga
 this brother with sb.nz-pl kill+pl.o (3s)-uPST+uDEF+uDUR
 (=four)

+nSJV+asr+uMOT aa-tĩnĩ tã-sã-nêê mēne kã
 3c=care+for 3p-uPST+uDEF+uDUR+uMOT-nom nsb.nz in
 nominal S'

'He kills four because they are caring about each other.' (The monkeys don't flee; they try to help the wounded one.)

In the example below, however, the underlined transitive verb stem is coreferential with the superordinate clause subject:

(6.60)T eé bó tã-mãã alóp ka
 there tz 3p-pPST+uDEF+uDUR+nSJV+asr+uMOT 3s smell

va aã-nĩt alóp ka-nêê a-kac
 imbibe this-amount+dm 3s (pPST+pDEF+nDUR)-go-nom 3c-involve
 nominal S'

mãt kã
 sb.nz in

'There they smelled him close by when he went (to be) with them.'

Coreferential anaphora will not be formalized in the syntactic rules here.

6.5 Rules for Auxiliary Stem Features

Phrase structure rules already given above transfer the value of the sentence functional type feature from a S to a S' and then to the Aux stem within it. Rule (4.1) S Composition spreads the sentence functional type feature value of the S to the matrix S' it immediately dominates, as well as to the Pre-S and Post-S nodes. Rule (5.6) S' Composition (revised) assigns the sentence functional type feature value of the S' to its Aux stem. The same rule assigns to the Aux stem a value for its sentence structural type feature, COP. The other Aux stem features and their values (except mood, SJV) are introduced by phrase structure rule (6.61) below.

(6.61) Auxiliary Stem Feature Composition:

Aux'st→	Aux'st
αS.F.TY	αS.F.TY
βCOP	βCOP
	γPST
	δDEF
	εDUR
	ζMOT

If β is p, then γ, δ, ε, and ζ are all u (unmarked). If β is n, the possible values for γ, δ, ε, and ζ are specified in table (6.62), given the value for α.

For example, if αS.F.TY is impS.F.TY, then γPST is nPST, and δDEF can be either uDEF, nDEF, or pDEF. The values of u, n, and p for the feature DEF imply values of p, n, and n, respectively, for the feature DUR. The MOT feature value, ζ, can be u, go, or come.

Mood is not introduced by phrase structure rules as are the other Aux stem features. Instead, mood is determined by the presence or absence of certain Post-S particles. In assertative sentences the

(6.62) Cooccurring Feature Values on Noncopula
Auxiliary Stems:

	α S.F.TY	γ PST	δ DEF	ϵ DUR	ζ MOT			
asr	u	u	u		u go come			
	p	n p	u n					
nasr	u	u	u					
	p	n p	u n					
imp	n	u	u					
proh		n	n					
		p	n					
exh						u go		
let	u	u	u	u		u go come		
prev								
des								p
				n				n
sim				u				
psf	p		u					
nom	u							
	p	n p	n n					

mood is subjective if time-of-evidence or 'think' particles occur in the Post-S; otherwise mood is nonsubjective. In nSJV mood the aspect contrasts, which have been introduced by rule (6.61), are neutralized; aspect is always uDEF, uDUR. Both introduction of mood and aspect neutralization just in case mood is nSJV are accomplished by transformational rule (6.63).

(6.63) Mood and Aspect Adjustment:

W	-	Aux'st	-	X	-	Y	-	Z	
		asrS.F.TY				pSJV			
		α DEF							
		β DUR							
1		2		3		4		5	
1		2		3		4		5	\Rightarrow
		γ SJV							(obligatory)
		δ DEF							
		ϵ DUR							

Conditions:

(a.) If 4 occurs, $\underline{\gamma} = \underline{p}$, $\underline{\delta} = \underline{\alpha}$, and $\underline{\epsilon} = \underline{\beta}$.

(b.) Otherwise, $\underline{\gamma} = \underline{n}$, and both $\underline{\delta}$ and $\underline{\epsilon} = \underline{u}$.

In rule (6.63) W stands for the items preceding the Aux stem. The variable X stands for any items between the Aux stem and a Post-S pSJV particle, Y. The variable Z represents any following particles, clitics, or addressee terms.

As noted in Section 6.3, the person prefixes of prohibitive and exhortative Aux stems are always sentence initial (pS.I.). The person prefix of a 'let' Aux stem can be sentence initial or not (uS.I.). The person prefixes of all other Aux stems are never sentence initial (nS.I.). Transformational rule (6.64) assigns the S.I. feature and its correct value to each person prefix. This rule must be ordered before

the preposing rules, which have to take note of the S.I. value of Aux stem person prefixes.

(6.64) Auxiliary Stem Person Prefix S.I. Value Assignment:

X	-	Ppfx	-	Aux'st	-	Y	
				α S.F.TY			
1		2		3		4	
1		2		3		4	\Rightarrow
		β S.I.					(obligatory)

Conditions:

- (a.) If α = proh or exh, then β = p.
- (b.) If α = let, β = u.
- (c.) Otherwise, β = n.

To illustrate the functioning of the rules which assign features and their values to Aux stems, the derivation of a Gavião sentence meaning 'You weren't sleeping' is given below. This is an assertative sentence and a S marked asrS.F.TY is selected. Then this is expanded by rule (4.1) S Composition:

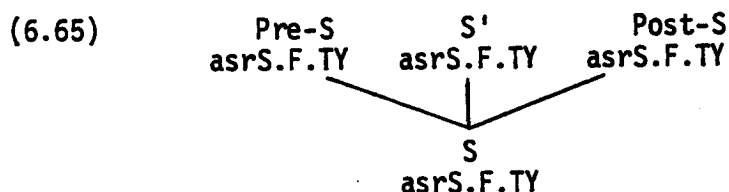

Next, by the phrase structure rules for the Pre-S and Post-S, discussed in Section 7.0, asrS.F.TY matrix S elements are selected. In this case the sentence-initial particle ôo 'negative', and the pSJV time-of-evidence particle kí-nap 'indefinite time of evidence', occur.

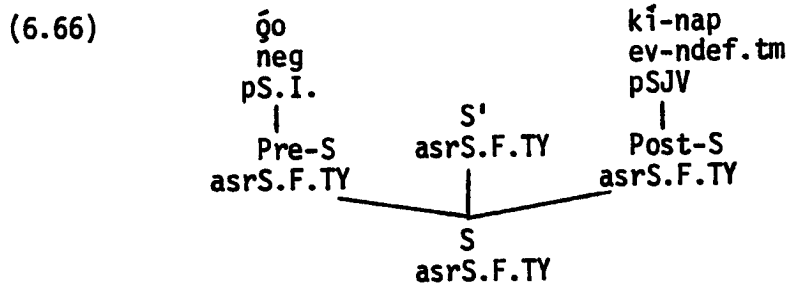

By rule (5.6) S' Composition (revised) the subject person prefix, Aux stem, and VP are selected. From this rule the Aux stem receives the features and values asrS.F.TY and nCOP.

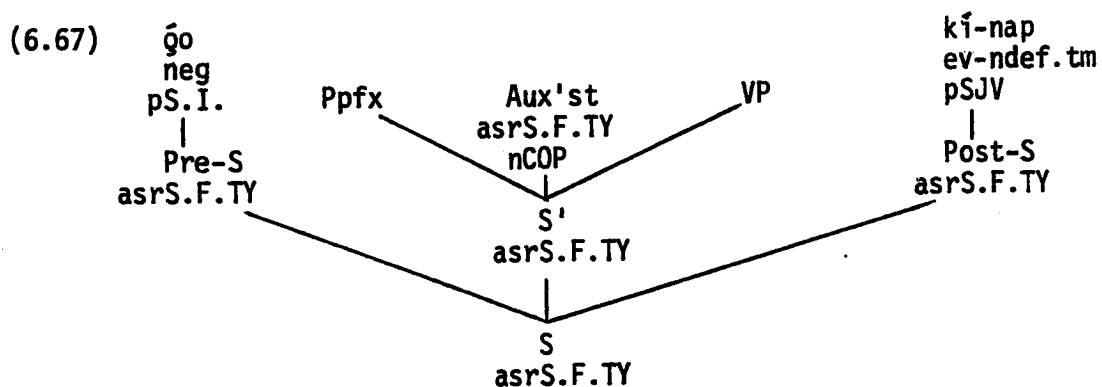

By rule (6.61) Auxiliary Stem Feature Composition the Aux stem features and values pPST, nDEF, uDUR, and uMOT are selected.

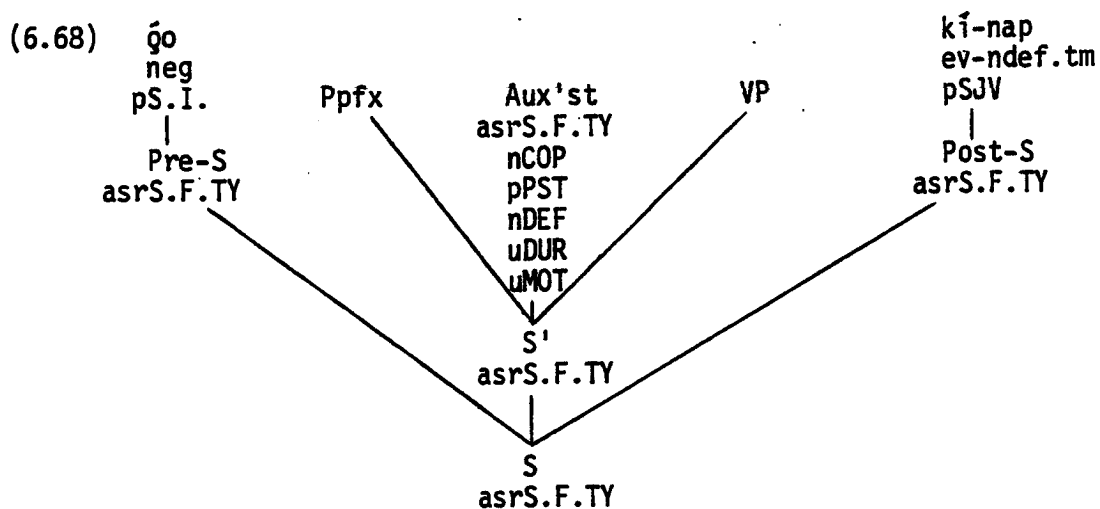

After the VP has been expanded and lexical insertion has taken place, rule (6.63) Mood and Aspect Adjustment copies the feature pSJV onto the Aux stem. Aspect is not neutralized since the mood is pSJV. Rule (6.64) Auxiliary Person Prefix S.I. Value Assignment assigns the Aux stem person prefix the feature and value nS.I.: since the Aux stem is asrS.F.TY. The spell-out rules (6.1) give the proper phonological representation for the Aux stem given its feature values. The result:

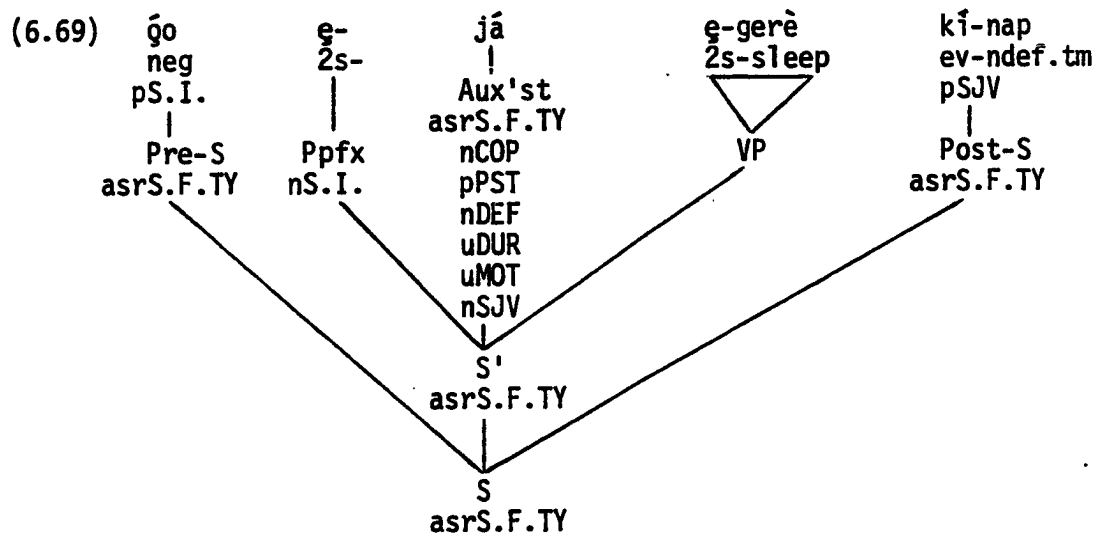

'You weren't sleeping.'

7.0 MATRIX S ELEMENTS, WH ELEMENTS, DISCOURSE PRONOUNS, PRE-S, AND POST-S

Matrix S elements are those particles, suffixes, and demonstrative phrases which are constituents of a matrix S but not constituents of a matrix S'. Since the number of M.S.E.s is quite large and some of them are fairly rare, their cooccurrence possibilities cannot be entirely determined from the available data. The M.S.E.s occupy two positions: Pre-S and Post-S. Cooccurrence restrictions hold within each of these two groups of M.S.E.s. Cooccurrence restrictions do not hold between the two groups except that sentence functional type restricts the occurrence of some M.S.E.s in both Pre-S and Post-S.

In this section the Pre-S M.S.E.s are dealt with first. They are generated by phrase structure rules rewriting Pre-S. Some S-initial items (WH elements and discourse pronouns), which are not introduced by the Pre-S rewrite rules, are inserted under appropriate lexical categories within the S'. Three preposing transformations then operate, preposing phrases or embedded clauses within S' under certain conditions and raising one phrase or clause into the Pre-S under certain circumstances. Three minor 'housekeeping' transformations involving Pre-S M.S.E.s occur also.

The phrase structure rules for the Post-S M.S.E.s and three minor transformations affecting them are given in the last two parts of this section.

7.1 Pre-S M.S.E.s: Phrase Structure Rules and Syntactic Features

As mentioned and illustrated in Sections 2.1 and 2.2 above, the analysis adopted here recognizes a Pre-S node which dominates the

Pre-S M.S.E.s. This node is like the Pre Sentence node used in some generative descriptions of English to introduce abstract triggers for questions, imperatives, negation, etc. With the exception of the question marker, Q, the items dominated by the Pre-S node in Gavião are not abstract, however.

As far as I can see there are no conclusive language-internal arguments that either the Pre-S or Post-S nodes are necessary. Alternatively, one could generate the Pre-S and Post-S M.S.E.s at the time of rewriting S to give a structure without the Pre-S or Post-S nodes:

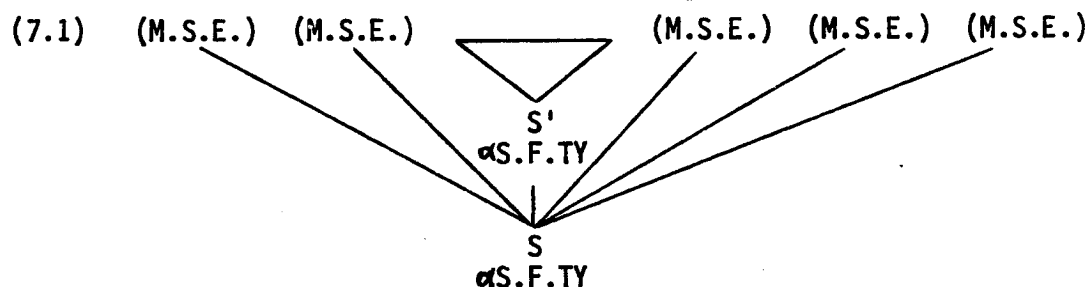

There would have to be different rewrite rules for each sentence functional type value of S in that case, but the further expansion of Pre-S and Post-S nodes would be avoided. The preposing rules mention the Pre-S node. It is probably possible to write these rules so that they do not refer to it, though this would be somewhat less convenient, I think. For expository purposes it is easier to assume the existence of Pre-S and Post-S nodes, and that will be the course followed here, though it is acknowledged that the matter is certainly debatable.

Most of the Pre-S M.S.E.s are pS.I. That is, they must be in S-initial position in surface structure. The pS.I. M.S.E.s are generated in S-initial position by the base rules. Except in the case

where one M.S.E. dominates another, there is only one S-initial position per S, so most Pre-S M.S.E.s are mutually exclusive, even if semantically they are perfectly compatible (e.g. bô 'already' and até 'affirmative').

Three M.S.E.s are nS.I., that is, never S initial. One M.S.E. is uS.I.; it can be either sentence initial or not. Some M.S.E.s are bipartite, the second part (apparently) being a scope marker. These are written with three dots between them. M.S.E.s are shown in normal orthography unless there is irregular allomorphy, in which case the base form is given in double slashes. All M.S.E.s are pS.I. unless otherwise marked.

The composition of an assertative Pre-S is given in (7.2):

(7.2)	{	//â'q// 'negative'	
		<u>até</u> 'affirmative'	
		<u>bô</u> 'already'	
		<u>met</u> 'already, past'	
Pre-S → asrS.F.TY	{	{ DemP 'demonstrative phrase' }	- (//bók//)
		{ ∅ null }	nS.I. 'topicalization'
	}	<u>âne...kî</u> 'rhetorical question'	

There are two M.S.E. positions in an assertative Pre-S. The top four particles in (7.2) occurring in initial position are unrestricted by sentence functional type; they can occur in a Pre-S with any sentence functional type value (except proh and exh, both of which have a null Pre-S). The particle met 'already, past' occurs only with pPST Aux stems, but this restriction will not be formalized. The

topicalization particle, //bók//, optionally occurs (1) after a demonstrative phrase or (2) if no pS.I. particle occurs. The initial position 'rhetorical question' M.S.E. can occur only in an assertive Pre-S.

Nonassertive Pre-S composition is specified by rule (7.3) below. The standard abbreviations for common particle glosses are used.

(7.3)

Pre-S → nasrS.F.TY	}	//ā'q// 'neg'	}	- <u>té</u> 'nasr' nS.I.
		<u>até</u> 'aff'		
		<u>bó</u> 'already'		
		<u>met</u> 'already, past'		
		{ DemP } ∅ - (//bók//) 'tz' nS.I.		
		<u>Q</u> 'question'		
		<u>ā bó na</u> 'could be that...'		
		{ <u>até</u> 'aff' ∅ } - <u>kiri...kí</u> 'impossible' nS.I.		
		∅ - <u>de...kí</u> 'tentative negation' ? uS.I.		
		<u>ā-de</u> 'maybe' (<'which-nasr.tz')		
<u>ā-tét</u> 'show me where...' (<'which-exct')				
<u>déét...já</u> 'speaker uncertain if...'				
<u>pazókáde...kí</u> 'perhaps'				

Rule (7.3) provides three M.S.E. positions in a nonassertive Pre-S. When the nonassertive particle té occurs, the initial

position can be filled by a p.S.I. particle unrestricted by sentence functional type or by a demonstrative phrase, which is similarly unrestricted. Or the initial position can be unfilled. If a demonstrative phrase or nothing occur initially, then the topicalization particle can optionally occur in second position. If the nonassertative particle té occurs, the initial position can also be filled with the abstract question marker, Q, or the expression â bô na 'could be that...' (?<'which-topicalization-possible').

There is insufficient data to determine which M.S.E.s can occur in initial position if the 'impossible' particle occurs. The 'affirmative' particle was approved by an informant, but no other particles were. The tentative negation particle is unmarked for sentence-initial status. It can be preceded by nothing, but other possibilities are undetermined. The last four particles listed in rule (7.3) occur only sentence initially, and no other M.S.E. can follow them in the Pre-S.

Rule (7.4) is a hypothesis about the composition of a Pre-S of the imperative, 'let', preventative, or desiderative sentence functional types:

$$(7.4) \quad \left. \begin{array}{l} \text{Pre-S} \\ \left\{ \begin{array}{l} \text{imp} \\ \text{let} \\ \text{prev} \\ \text{des} \end{array} \right\} \text{ S.F.TY} \end{array} \right\} \left\{ \begin{array}{l} //\hat{a}'q// \text{ 'neg'} \\ \underline{\text{até}} \text{ 'aff'} \\ \underline{\text{bô}} \text{ 'already'} \\ \underline{\text{met}} \text{ 'already, past'} \\ \left\{ \begin{array}{l} \text{DemP} \\ \emptyset \end{array} \right\} - (//\text{bôk}//) \text{ 'tz'} \end{array} \right\} - (\underline{\text{té}}) \text{ 'nasr'}$$

The imperative, 'let', preventative, and desiderative sentence functional types are much less common than the assertative and non-assertative types. The available evidence suggests a hypothesis that only the M.S.E.s unrestricted by sentence functional type, the topicalization particle, and the nonassertative particle té can occur in a Pre-S with one of these sentence functional type values. This is stated in (7.4).

The Pre-S of a prohibitive or exhortative sentence can only be null since the Aux stem person prefix is then pS.I.

(7.5) Pre-S → ∅
 {proh} S.F.TY
 {exh }

A Pre-S (or S or Post-S) cannot have the simulfactive, postfactive, or nominal sentence functional type values. These values occur only on embedded clauses and the Aux stems within them. Occasionally M.S.E.s are observed in sentence fragments containing those types of embedded clauses, however.

7.2 Demonstrative Phrases

A sentence-initial demonstrative phrase locates the sentence in time or space:

(7.6)T eé téét mää arañ-éèc sáp ma'á
 then exct 1s+pPST+asr chicken-pl house get

'Then I made a chicken house.' (gathered the thatch)

(7.7)T áá bó papá séríit máa a-+lǎ ále
 here tz father name asr 3c-fall+dm fut

'Here Papá Séríit is about to fall.' (looking at his photo)

A demonstrative phrase contains a demonstrative indicating proximity to someone (pPROX). The demonstrative can be followed by the particle tígi, indicating that place, not time, is meant. The DemP is optionally followed by one or more qualification particles:

$$(7.8) \quad \text{DemP} \rightarrow \left\{ \begin{array}{l} \text{Dem} - (\text{tígi}) \\ \text{pPROX} \\ \text{DemP} - \text{Prt.q} \end{array} \right\}$$

The demonstratives gá 'proximate to first person', jê 'proximate to second or third person', eê 'proximate to indefinite person', and ã 'interrogative' are attested in DemPs. The qualification particles téet 'exact(ly)', and teé 'continuing', are attested.

7.3 Questions and WH Elements

7.3.1 Polar Questions, Nonassertative té, and WH Questions

Gavião polar (yes/no) questions have the nonassertative particle as the first overt element in the sentence. An abstract question M.S.E., Q, is postulated to occur before té, blocking non-WH phrases or embedded clauses from being preposed:

(7.9)T té má sá a-cígĩña me-pi-á
 (Q) násr someone násr 3c-urinate 2s-from-s.m

'Is one of you going to urinate?'

(7.10)T té gá panóóc pére mi teé tá-sá
 (Q) násr this lpi nature use cont 3p-násr

mákiĩ-á
 (3s)-make+pl.o-s.m

'Do they make (them) in this, our way?'

(7.11)T té ǒò-'-ǐ-i pít má vǎ sǎ-ǎ
 (Q) nasr ǐs-enter-nz with some hole nasr-s.m

'Will I fit?' ('Is there a hole associated with my entering?')

The Pre-S of a polar question sentence is diagrammed below:

(7.12) Q té
 pS.I. nasr
 / nS.I.
 Pre-S

In nonassertative statements (tentative observations, suggestions, etc.) using té, the particle is never S initial. According to the analysis adopted here, té is a nS.I. M.S.E. and something overt must precede it if Q does not. Examples of nonassertions with té:

(7.13)T a-vesot ma-ǎǎ bó té-aké-e-na
 3c-merchandise tr-go+pl.X tz nasr-3s+nasr-th-lk

'He's bringing his merchandise.' (guessing his activity)

(7.14)T a-mǒñ-gǎ teé té gǎ sé-e-na aa-co ǐǐ
 3c-one-in cont nasr this nasr-th-lk 3c-photo take

'This (one) takes his photo alone.'

(7.15) eé téét té pazó éèt majóp
 then exct nasr other+person pPST+pDEF+nasr claypit

cǐgǎã ma'ǎ
 blind get

'Then the other one made a hunting blind on the claypit.'

In nonassertative statements with té (such as the three immediately above), the Pre-S contains a phrase or M.S.E. followed by té. The Pre-S for (7.15) is diagrammed below as (7.15a):

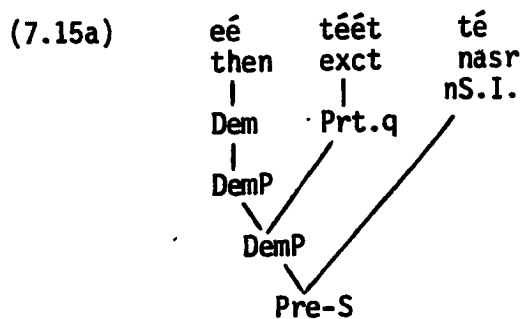

If the particle té is preceded by a phrase which contains the WH pronoun, mé, or the WH demonstrative, á, then the sentence is a WH question:

(7.16)T mé áco té jè -á
 who(se) photo nasr this (pCOP+nasr) -s.m

'Whose photo is this?'

(7.17)A mé kalà té e-zé-e-na-á
 what want nasr 2s-nasr-th-1k-s.m

'What do you want?'

(7.18)T á té pa-jíp c-ír-á
 where nasr 1pi-sweetheart nasr+dm-s.m

'Where is our sweetheart?' (which of the men in the photos)

(7.19)T á p-ígí tá té-aké-e-na-á
 which (one's) offspring with nasr-3s+nasr-th-1k-s.m

'Whose daughter is he with?'

(7.20)T á va té zā ále ní
 which eat nasr 1s+nasr fut ?

'Which will I eat?'

(7.21)T á koc té me-sá-va sá-á
 which at nasr 2s-house-hole nasr-s.m

'Where is your door?'

(7.22)T á tígi té pa-zé-e-na sa-ga vāneè-p
 which place nasr lpi-nasr-th-1k 3s-kill (3s)-exit-nz

ké-e-na
 in-th-1k

'Where do we kill him when he comes out?' (answer: 'On the head.')

(7.23)A á-nap té e-zá gakoráá
 which-number nasr 2s-nasr hunt

'How often do you hunt?' (number of times)

(7.24)A á-nám-dígi té e-záno sá a-ka tírí-á
 which-number-time nasr 2s-brother nasr 3c-field burn-s.m

'When does your brother burn his field?'

(7.25)T á-nát táǵ-i té me-sé-e-na mákī-ri
 which-extent big+pl-use nasr 2s-nasr-th-1k (3s)-make+pl.o

kīī eé-na bosap kīī bó-á
 -pl.X ints th-1k pots ints rm.pst-s.m

'How big did you used to make pots?' (The sentence is aberrant in that the direct object, 'pots', is displaced to the rear--an afterthought according to an informant.)

(7.26)T á-na té me-sé-e-na gǵóc koñò eé-na
 which-1k nasr 2p-nasr-th-1k ground dig th-1k

'How did you dig holes in the ground like that?'

(7.27)T á-na mát té jè kī-nāā-á
 which-1k sb.nz nasr that (pCOP+nasr) ev-prox.tm-s.m

ñāāñ-á
 intro+topic-s.m

'What's that?'

(7.28)T á-na méne ká té-aká aa-béa
 which-1k nsb.nz in (=because) nasr-3s+nasr 3c-bent+over

azīīp--tá eé-na-á ñāāñ-á
 horizontal+dm-be th-1k-s.m intro+topic-s.m

'Why is she stooped over like that?'

The structure of each of the above WH phrase examples is diagrammed below. These are all in the Pre-S.

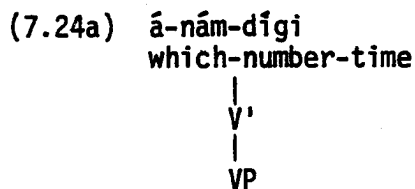
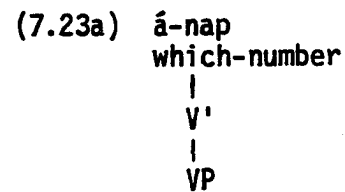
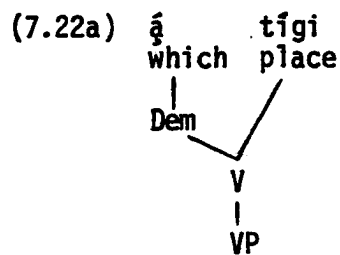
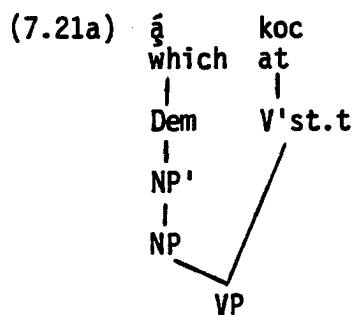
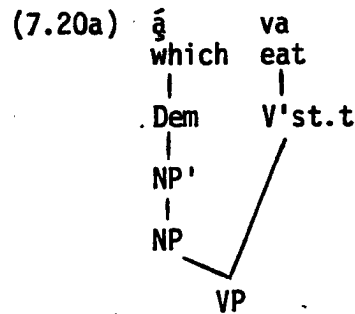
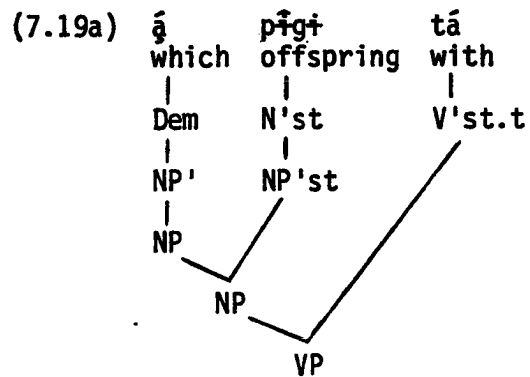
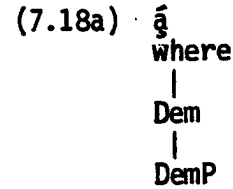
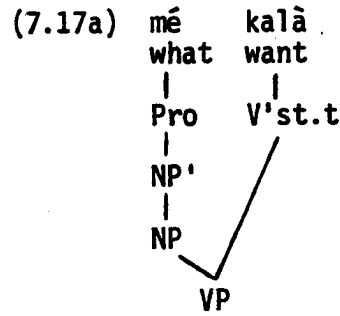
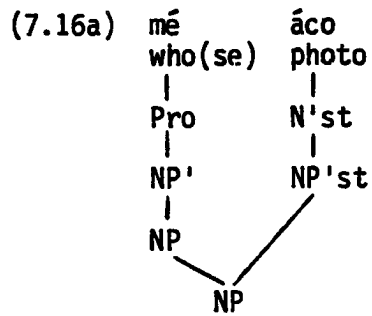

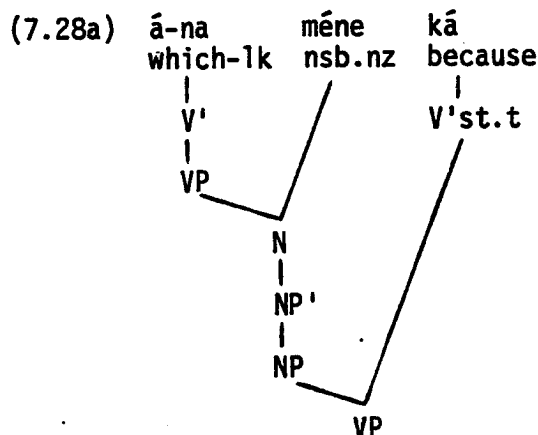
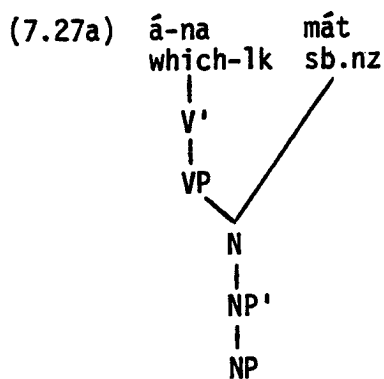
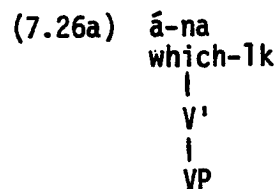
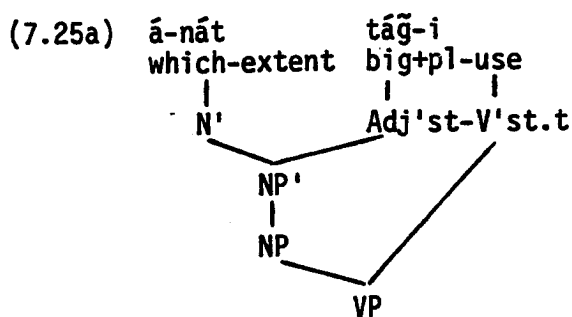

All of these WH phrases are generated by the phrase structure rules which generate any other Gavião phrases. The WH pronoun, $\underline{m\acute{e}}$, has the same distribution as any other pronoun, and the WH demonstrative, $\underline{\hat{a}}$, has the same distribution as any other pPROX demonstrative. In Gavião, WH words are not extracted from phrases or embedded clauses; rather the whole phrase or clause is placed in initial position in the Pre-S. Two of the above examples are diagrammed below to show the position of the WH phrase. In (7.18b) the vertical arrow indicates that $\underline{\hat{a}}$ was inserted directly into the DemP, which was generated in the Pre-S. The arrow in (7.21b) indicates that $\underline{\hat{a}}$ was inserted into a VP. The two horizontal arrows indicate that the VP was then moved by two preposing rules, first to the front of the S', then into the S-initial position under \underline{Q} in the Pre-S.

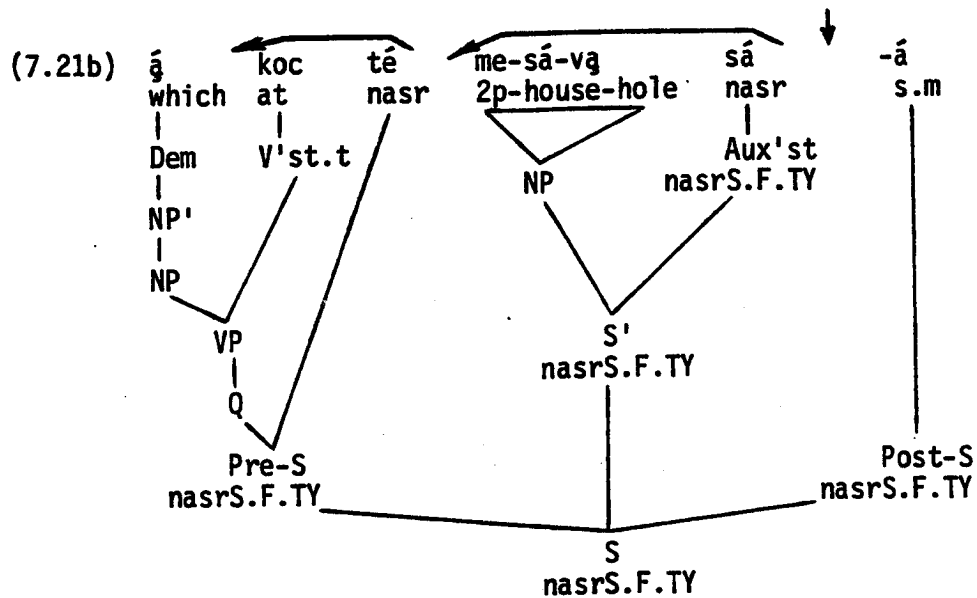
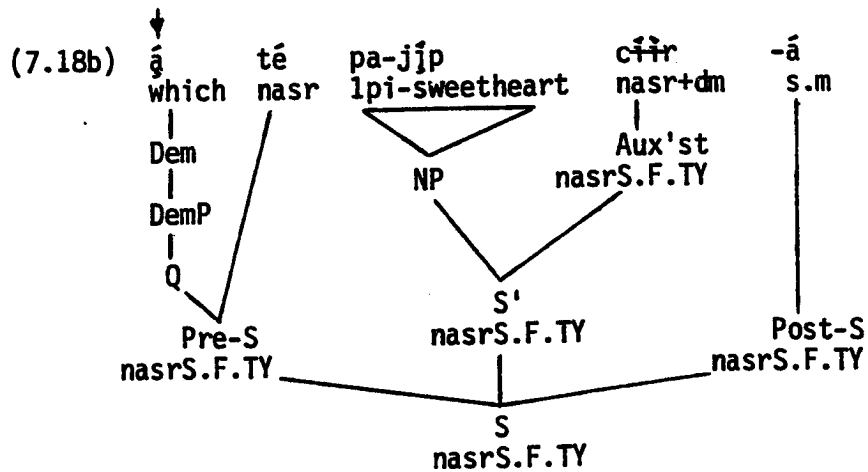

In all the above examples the WH element has been in a phrase but not in an embedded clause. Although there are no text examples at hand of questions which contain a WH element in an embedded clause, the one example of a subjunctive embedded clause does contain ā, and the entire clause, as expected, does occupy the initial Pre-S position preceding té:

(7.29)T "'eeroo! ā koc ō-bag-ēēc s̄ali
 lament whichever at 1s-offspring-pl pSUBJUNCTIVE

S'

té zā eé-na ô-bag-êêc kalâ-â eeroo! eeroo!
 nasr 1s+nasr th-1k 1s-offspring-pl miss-s.m lament lament

alóp mää-â" kî-ip
 he pPST+asr-s.m ev-rc1

'He said, "Eeroo! Wherever they may be, I miss my sons. Eeroo!
 Eeroo!"'

In the above example, â koc translates as 'wherever' instead of 'where'. The 'WH-ever' interpretation can also obtain when â occurs with the M.S.E. kîri...kî 'impossible':

(7.30)T aāv-â â-na kîri panóóc
 yes-s.m whichever-1k impossible lpi-(nPST+pDEF+nasr)

pa-mâ-zâg-atí-a âle kî
 lpi-poss-hunger-pain-vz fut scope

'Yes. We can't get hungry.' ('Whichever way, we can't get hungry.')

The VP dominating â-na is in the initial position of the Pre-S in (7.30), preceding kîri. Although â can occur with kîri...kî, the WH pronoun, mê, cannot.

As analyzed here, all Gavião questions contain an abstract question marker, Q, in S-initial position. As illustrated in (7.12), the Q immediately precedes the particle té in polar questions. In non-assertative statements with té, as illustrated in (7.15a), the S-initial position is filled by a phrase or M.S.E., not by Q. In WH questions, as diagrammed in (7.18b) and (7.21b), the Pre-S is the same as that of polar questions except that Q dominates a WH phrase or a WH embedded clause.

The WH phrases or WH embedded clauses under Q are moved there by preposing operations, with one exception. A demonstrative phrase containing the WH demonstrative, â, can occur under Q, but this DemP

cannot have moved into the Pre-S by preposing since initial DemPs are generated in place by Pre-S rewrite rules. These Pre-S rewrite rules cannot generate both Q and DemP simultaneously since both are pS.I. M.S.E.s. To resolve this, Q will be optionally rewritten by rule (7.31) to dominate a DemP, which, if it occurs, is obligatorily filled by á.

(7.31) $Q \rightarrow (\text{DemP})$

The Q in both polar questions and WH questions provides a formal basis for their semantic interpretation as questions. There are three syntactic reasons for recognizing an abstract Q M.S.E.: (1) This provides a principled explanation for the fact that no pS.I. M.S.E. particles (e.g. até 'affirmative') occur in questions though they may occur in nonassertative statements with té: the S-initial position is occupied by Q. (2) Likewise, the fact that non-WH phrases cannot be preposed in questions is explained if Q occupies the S-initial position. (3) The fact that the topicalization particle, //bók//, cannot occur in questions but can occur in nonassertative statements can be accounted for neatly by not introducing //bók// after Q in the Pre-S composition rule (7.3). Since //bók// can be introduced when no pS.I. M.S.E. occurs and cannot be introduced if a nonphrasal pS.I. M.S.E. is present, we expect that there is some nonphrasal pS.I. M.S.E. present in questions which explains the absence of //bók//. The abstract Q serves as that M.S.E. In the following sentence the underlined thought/quote is a nonassertative statement, not a question, even though it contains a WH element, since //bók// occurs and therefore Q does not:

..

(7.32)T "eé ká bô tâ-mâà 'á-na bô té
 that in tz 3p-pPST+asr which-lk tz nasr
 thought/quote

saké-e-na-á' kaj-á" kí-ip
3s+asr-th-lk-s.m (3s)-involve-s.m ev-rc1

'At that they wondered what it was he was doing.'

If the underlined bô (//bók//) in (7.32) were deleted, the quoted sentence would be a true question and the translation given by informants then is, 'At that they asked what he was doing.'

7.3.2 WH Insertion

Any formulation of the insertion of Gavião WH elements must take into account the following facts:

- (i.) Only one WH element can occur in a S.
- (ii.) The WH element must occupy S-initial position in surface structure (implying no side-by-side cooccurrence with any pS.I. M.S.E.).
- (iii.) WH elements can be inserted only in certain lexical nodes. For example, a cross-referencing VP cannot contain a WH element.

These same three facts obtain for the insertion of the discourse pronouns, mât and méne, also. If the WH element were introduced as a M.S.E. in the Pre-S and subsequently attached to the front of a phrase after the phrase had moved into initial position by preposing, then restrictions (i.) and (ii.) would be met. However, restriction (iii.) could not be met, since there is no way of guaranteeing that the phrases generated in the sentence would provide a suitable attachment site, especially since a minimal S' can be just a person prefix and Aux stem, with no constituent phrases at all.

So WH elements will not be generated in Pre-S position. Rather

they will be inserted after the expansion of the phrase structure rules but before the insertion of other lexical items. This insertion (so far as it is known, and disregarding subjunctive clauses) is described informally below:

(7.33) WH Insertion (informal):

- (a.) Insert á into a DemP (if there is one) preceding té in a nonassertative Pre-S.
- (b.) Otherwise, if either té 'nonassertative', or kíri...kí 'impossible', are in the nonassertative Pre-S, preceded by nothing or by Q, then optionally insert á under any pPROX Dem node which occurs at the beginning of a phrase immediately dominated by S'.
- (c.) Otherwise, if Q is in the nonassertative Pre-S, optionally insert mé under any Pro node which occurs at the beginning of a phrase immediately dominated by S'.

WH elements are pS.I. If a condition is added to the preposing transformations that they obligatorily prepose a pS.I. item, then they will eventually deliver the WH element to the S-initial position. That position has to be vacant or filled by Q as a condition for WH insertion. So by insertion a WH element is placed into the front of a maximal phrase, and then by preposing that phrase and any embedded clauses containing it are fronted. This will be illustrated in Section 7.5.

A simpler solution would be to move a phrase into the Pre-S by preposing operations and then optionally insert a WH element just in case a suitable attachment site is S initial. However, this would entail doing lexical insertion after, not before, the transformations.

7.4 Discourse Pronouns

The two discourse pronouns are phonetically identical with the nominalization particles: mát, 'substantive discourse pronoun', and

méne 'nonsubstantive discourse pronoun'. Examples of their use:

(7.34)T "mát koc tá-sá-àt bõ táa-jaàc mää
that at 3p-sim tz 3p-owners (=fathers) pPST+asr
 S'

tá-kaliít a-vak-píít a-porocójó-á" kí-ip
 3p-miss+dm 3c-cry-go+out+dm 3c-tr+get+thin-s.m ev-rc1

'When they were there, their fathers missed them, cried, and became thin.'

(7.35)T méne ká bõ ci-serat mää, "á'q ále-á"
that in tz 3s-uncle pPST+asr neg fut-s.m

kaj-ã
 (3s)-involve-s.m

'At that his uncle said, "No, it won't," to him.'

The discourse pronouns refer to a thing or event in the previous sentence. Only one can occur per S, and it must be S initial in surface structure. Notice that in example (7.34) mát is in initial position within its embedded S', matrix S', and S. Discourse pronouns cannot appear in exhortative or prohibitive Ss, since these have pS.I. Aux stem person prefixes. Discourse pronouns are inserted and then fronted like the WH elements:

(7.36) Discourse Pronoun Insertion (informal):

If no WH element has been inserted and there is no pS.I. M.S.E. in a Pre-S with the sentence functional type value asr, nasr, imp, let, prev, or des, then optionally insert either mát or méne under any Pro node which occurs at the beginning of a phrase immediately dominated by S'.

7.5 Preposing Transformations

Rules (5.13) and (4.32) for preposing within S' have been discussed at length above. These are now revised to take into account

the requirement that if a pS.I. element occurs in a phrase or clause in a S' then that phrase or clause and no other must be preposed.

(7.37) Predicate NP Preposing within S' (revised):

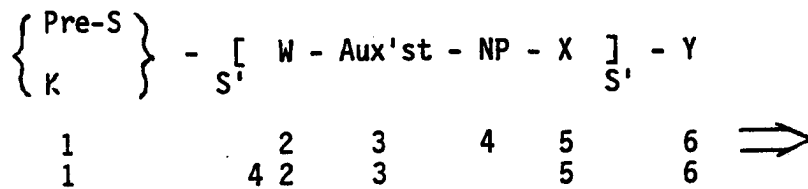

Conditions:

- (a.) 4 must be immediately dominated by S'.
- (b.) 2 contains no pS.I. element.
- (c.) obligatory
 - (i.) if 1 is K or a null Pre-S and W is just a nS.I. person prefix, or
 - (ii.) if 1 is a Pre-S containing only nS.I. M.S.E.s and W is just a person prefix, or
 - (iii.) if 4 is pS.I.
- (d.) optional (provided 4 is not pS.I.)
 - (i.) if 1 is K or a null Pre-S and W is a NP or uS.I. person prefix, or
 - (ii.) if 1 is a Pre-S containing a pS.I. M.S.E.

Application: Applies once to each S', in any order. Applies before rule (7.38), { VP, S', S'-ā } Preposing within S'.

Rule (7.37) differs from rule (5.13) only in the addition of condition (b.) above, which blocks preposing past a pS.I. element, and the addition of condition (c.iii), which ensures that a pS.I. predicate NP will be preposed if it occurs. The revision of rule (4.32) is given below.

(7.38) { VP, S', S'-ā } Preposing within S' (revised):

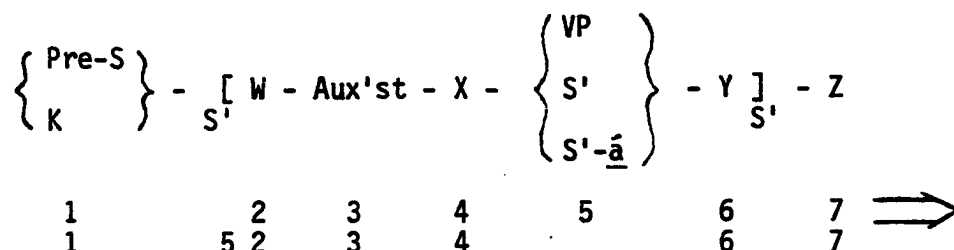

Conditions:

- (a.) 5 must be immediately dominated by S'.
- (b.) 2, 4, and 6 contain no pS.I. element.
- (c.) obligatory
 - (i.) if 1 is K or a null Pre-S and W is just a nS.I. person prefix, or
 - (ii.) if 1 is a Pre-S containing only nS.I. M.S.E.s and W is just a person prefix, or
 - (iii.) if 5 contains a pS.I. element.
- (d.) optional (provided 5 contains no pS.I. element)
 - (i.) if 1 is K or a null Pre-S and W contains a NP or uS.I. person prefix, or
 - (ii.) if 1 is a Pre-S containing DemP, Q, or de...kī.

Application: Applies after rule (7.37), Predicate NP Preposing within S'. Applies once to each S', with no order of application (no cycle).

The revisions are conditions (b.) and (c.iii), which together prevent preposing past a pS.I. element and guarantee that if one VP or embedded clause contains a pS.I. element only that VP or clause will be selected for preposing.

Rules (7.37) and (7.38) ensure that a phrase or embedded clause is in matrix-S'-initial position if the Pre-S contains only nS.I. M.S.E.s. If the Pre-S is null these rules ensure that a phrase or

embedded clause or uS.I. or pS.I. person prefix will begin the matrix S' and the S.

Any phrase or embedded clause which does not contain a pS.I. element and which immediately follows the Pre-S can be further preposed into S-initial position if no pS.I. M.S.E. is occupying that position. This preposing into the vacant S-initial position is obligatory if a nS.I. M.S.E. follows that vacant initial position. It is optional if the Pre-S contains only a uS.I. M.S.E.

If the phrase or embedded clause immediately following the Pre-S does contain a pS.I. element, then it is obligatorily preposed into S-initial position.

In the examples below the S.I. status of M.S.E.s in the Pre-S is marked and the phrase or embedded clause which has or has not been preposed into S-initial position is underlined.

Preposing blocked by a pS.I. M.S.E.:

(7.39)T eé téét té eé-na zāân-éèc teé
 then exct nasr th-lk warrior-pl cont
 (pS.I. DemP) nS.I.

jā-ka bāckít kac
 pPST+nDEF+uDUR+nasr-go squirrel involve

'Then the warriors arrived like that with Squirrel?'

Preposing blocked by a pS.I. M.S.E.:

(7.40)T té āā panóóc pére mi teé tā-sá
 (Q) nasr this lpi nature use cont 3p-nasr
 pS.I. nS.I.

mākiî-ā
 (3s)-make+pl.o-s.m

'Do they make (them) in this, our way?'

Preposing optional with a uS.I. M.S.E.; did occur:

(7.41)T mā tā de alóp sã-a-na
 other with tentative+negation he nasr-this-lk
 uS.I.

kĩ-ini
 scope-sg.adrse

'He's not with anyone else here.'

Preposing obligatory with pS.I. element in phrase:

(7.42)T ã tígi té gát sã
 which place nasr w+sun nasr
 pS.I. nS.I.

'What time is it?' ('Which place is the sun?')

Preposing obligatory with nS.I. M.S.E.; S' preposed:

(7.43)T "eé-na alóp sã-ãt a-vak-píft bõ tá-mãã
 th-lk he sim 3c-cry-go+out+dm tz 3p-pPST+asr
 nS.I.

a-vãneè alóp kaj-ã" kĩ-ip
 3c-go+out him involve-s.m ev-rcl

'When he was crying like that they appeared with him.'

Pre-S is null, moot whether preposed phrase is in it:

(7.44)T díã teé sa-gã-t sé-e-na sa-ga kĩ-nap
 soon cont 3s-kill-nz pSJV+asr-th-lk 3s-kill ev-ndef.tm

'The hunter kills quickly.'

Instead of considering the matrix-S'-initial phrase or embedded clause to be preposed into S, it seems possible to maintain instead that the Pre-S M.S.E.s are postposed behind the phrase or embedded clause. I can see no conclusive language-internal arguments against this analysis, but there are several modest arguments which favor preposing instead.

In rule (7.45), when the initial position, J, is filled by Q and a WH phrase or WH clause is preposed, the preposed material is attached under Q.

Rules (7.37), (7.38), and (7.45) interact to prepose phrases and embedded clauses which in principle may be deeply embedded. Example (7.34) above illustrates that the preposing of a phrase containing a pS.I. element (in (7.34), the discourse pronoun, mát) involves 'pied-piping' any embedded clause dominating it. There are no text examples with embedding inside embeddings, but the diagrams below illustrate how the preposing rules given above, operating noncyclically, place a phrase into S-initial position. Below is the structure of a WH question in which the WH element occurs in a VP in an embedded clause (S'_3) inside an embedded clause (S'_2):

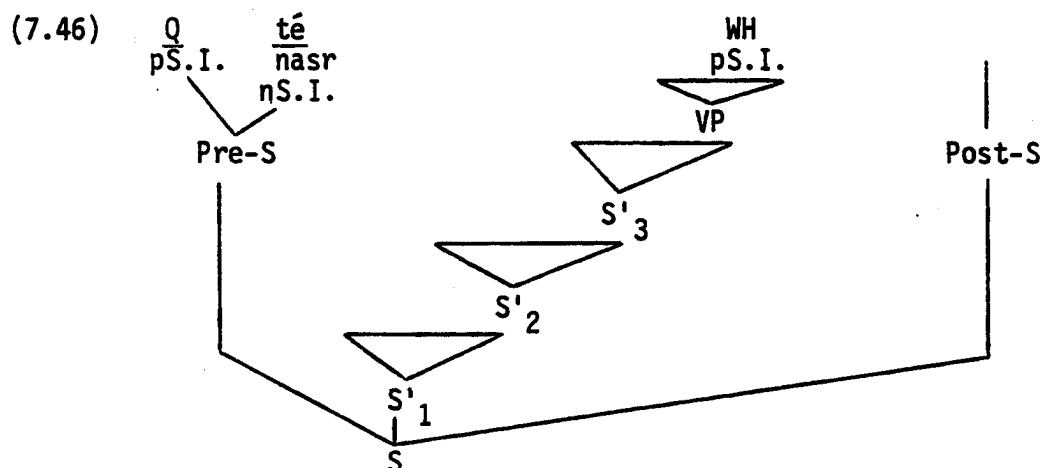

Let rule (7.37) apply first within, say, S'_2 . Since S'_3 contains a pS.I. element it is preposed to the front of S'_2 . Next, let rule (7.37) apply to, say, S'_1 . Since (looking way up the tree) S'_2 contains a pS.I. element, it is preposed to the front of S'_1 . Then let rule (7.37) apply to S'_3 . It will obligatorily prepose the VP

containing the WH element. The following structure has been produced:

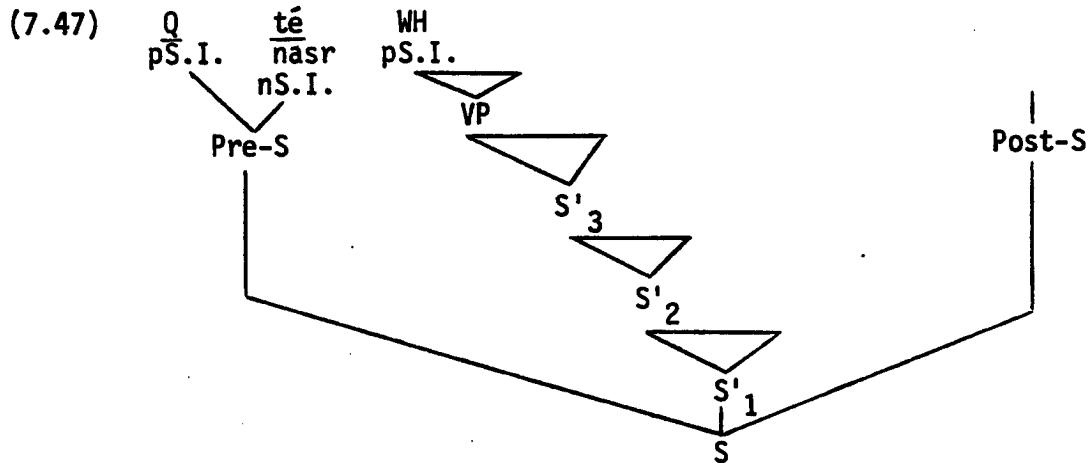

Next, since S'_2 contains a pS.I. element, occupies S'_1 -initial position, and is immediately dominated by S'_1 , it is obligatorily preposed by rule (7.45) to give the final result with WH in S-initial position and the pied-piped phrases all in the Pre-S under Q :

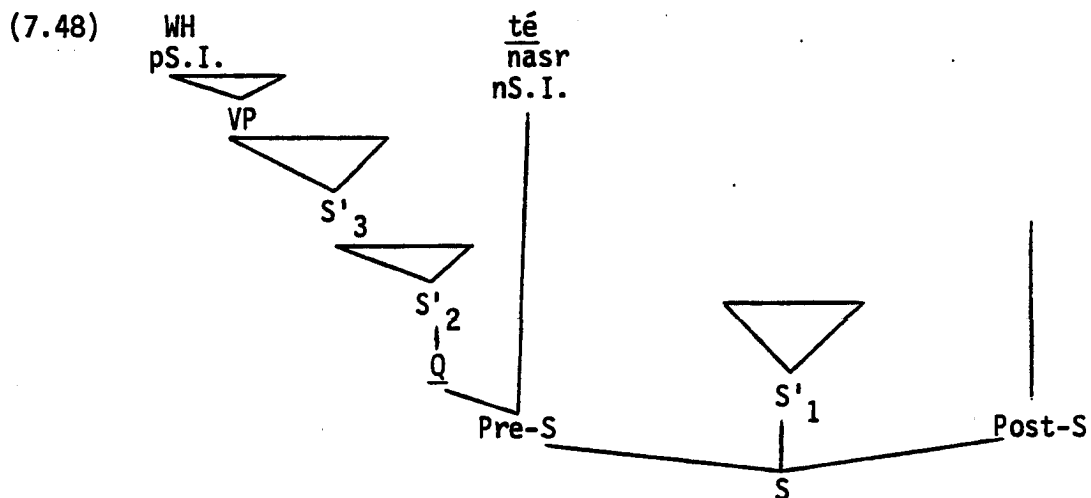

7.6 Minor Transformations Involving Pre-S M.S.E.s

7.6.1 Scope Marker Placement

There are five Pre-S M.S.E.s which consist of two particles, the

second one apparently being a scope marker:

<u>âne...kí</u>	'rhetorical question'
<u>kíri...kí</u>	'impossibility'
<u>de...kí</u>	'tentative negation'
<u>pazókáde...kí</u>	'speaker uncertain if...'
<u>déét...já</u>	'perhaps'

The second element, the scope marker, is introduced by phrase structure rules into the Pre-S and then moved into the Post-S by transformation. Its exact derived location cannot be determined from the data at hand, but lies somewhere after the first possible Post-S M.S.E. and before the addressee term.

Scope marker occurring after time-of-evidence particle (inside quoted sentence):

(7.49)T	"jê	teé	de	éèr-ê-na		
	that	cont	tentative+negation	pPST+pDEF+nasr-th-lk		
ê-gac	kí-nāā	<u>kí-á'</u>	ci-sac	māā	kaj-á"	
2s-involve	ev-prox.tm	scope-s.m	3s-wife	pPST+asr	(3s)-involve-s.m	
kí-ip						
ev-rc1						

'"That (one) didn't do it to you," his wife said to him.'

Scope marker occurring before addressee suffix:

(7.50)T	mā	tā	de	alóp	sá-a-na	<u>kí-ini</u>
	other	with	tentative+negation	he	nasr-this-lk	scope-
sg.adrse						

'He's not with anyone else here.'

Occasionally a scope marker is followed by a VP and/or occurs twice:

(7.51)T déét e-zá eé pí teé mé-e kalā
 uncertainty 2s-nasr that after cont other-pl want
 jā, mé-e pāné-e kalā jā
 scope other-pl recount-nz want scope

'I don't know if you will want more after that, want to tell more.'

Such examples appear to be false endings; the process is not productive.

Rule (7.52) assumes that the scope marker is placed in a position in the Post-S immediately after the position of the time-related M.S.E.s:

(7.52) Scope Marker Placement:

$$\begin{array}{ccccccc}
 \left[\begin{array}{c} X \\ \dots \\ \dots \end{array} \begin{array}{c} \dots \\ \dots \\ \dots \end{array} \left. \begin{array}{c} \dots \\ \dots \\ \dots \end{array} \right] & - & Y & - & \left[\begin{array}{c} \text{(M.S.E.)} \\ \text{time-} \\ \text{related} \end{array} - Z \right] \\
 \text{Pre-S} & & \text{Pre-S} & & \text{Post-S} & & \text{Post-S} \\
 1 & & 2 & & 3 & & 4 \quad 5 \\
 1 & & & & 3 & & 4 \quad 2 \quad 5 \quad \Rightarrow
 \end{array}$$

Condition: obligatory

In rule (7.52) the time-related M.S.E.s are those given by the rewrite of the Post-S node (presented below); the variable letters represent any string of syntactic elements.

7.6.2 Third Person Singular Subject Insertion and Topicalization Particle Attachment

When there is an overt subject NP immediately preceding the Aux stem, the postnominal form of the Aux stem occurs:

(7.53)T ā té gaác sá-ā
 where nasr mother nasr-s.m

'Where is Mother?'

However, examples of WH questions in which the subject NP is questioned (and preposed) show that the Aux stem is not in postnominal form, but instead is marked for third person singular:

(7.54)A á-na māt té sakā-ka a-vít ígí
 which-1k sb.nz nasr 3s+nasr-go 3c-food take+out

e-gā pí-á
 2s-field from-s.m

'Who gets food from your field?' (spontaneous translation of a census question)

When the particle té 'nonassertative' separates the NP subject and the Aux stem in a nonassertative statement the Aux stem is also marked for third person singular:

(7.55)A pa-gār-ābi té sakā a-vāneē
 1p-sun-face nasr 3s+nasr 3c-come+out

'Our day ("Day of the Indian") is coming around again.'

It appears that when the subject NP does not immediately precede the Aux stem, a third person singular subject is assigned to the Aux stem. This only manifests itself overtly when the initial Aux stem segment is //sá//; in all other cases the postnominal and third person singular Aux stem forms are phonetically identical since the third person singular person prefix is a zero morph.

Oddly, when //bók//, the topicalization particle (which often translates more like emphasis or a cleft construction), separates a NP subject from the Aux stem, the postnominal, not third person singular, form of the Aux stem occurs:

(7.56)T vāzet tēteé bō sé-e-na ma-kāá eé-na
 female only tz pSJV+asr-th-lk (3s)-tr-go th-lk

kī-nap
 ev-ndef.tm

'Only women do (pour) that.'

The behavior of //bók// can be accounted for by assuming that it attaches to the constituent in S-initial position. This is supported by the fact that //bók// is always preceded by phrases or clauses, never by M.S.E. particles. Rule (7.57) adjoins //bók// as a rightmost daughter to the phrase or clause node in S-initial position:

(7.57) Topicalization Attachment:

$$\begin{array}{ccccccc} \text{Pre-S} & [& X & - & //bók// & - & Y &] & - & Z \\ & & 1 & & 2 & & 3 & & 4 & \\ & & 1 > 2 & & & & 3 & & 4 & \Rightarrow \\ & & & & & & 3 & & 4 & \end{array}$$

Condition: obligatory

Application: Applies after (7.45), Preposing into S, and before (7.58), Third Person Singular Insertion.

Examples such as (7.54) and (7.55) can now be produced by a rule inserting a third person singular subject if no subject NP or person prefix immediately precedes the Aux stem:

(7.58) Third Person Singular Insertion:

$$\begin{array}{ccccccc} X & - & [& \text{Aux'st} & - & Y &] & - & Z \\ & & S' & & & & S' & & \\ & & 1 & & 2 & & 3 & & 4 & \\ & & 1 & & \underline{3s-2} & & 3 & & 4 & \Rightarrow \end{array}$$

Condition: obligatory

Application: Applies after rule (7.57), Topicalization Attachment.

7.7 Post-S Composition:

There are three particles which may or may not be M.S.E.s:

<u>kázét</u>	'seemingly'
//ǵ'q//...kǐ	'not, neither'
<u>nǐ</u>	(?)

The first of these, kázét, may be a qualification particle, but it also seems to occur in the Pre-S and possibly the Post-S. The second one, //ǵ'q//...kǐ, seems to occur in matrix S's or sentence fragments and appears to negate the VP occurring between the two constituents, opposing the negative idea to a positive idea. The third particle, nǐ, obligatorily occurs before the matrix S' subject when the M.S.E. particle nó 'opinion' occurs in the Post-S. However, nǐ also occurs before the subject or in the Post-S without nó, often with some idea of selection implied. I can offer no rules for these particles without more data. The Gavião particles which are clearly M.S.E.s are generated either in the Pre-S (Section 7.1) or Post-S (this section).

The Post-S M.S.E.s are grouped below into positions of occurrence. These groupings should be regarded as tentative. M.S.E.s which are semantically similar, which appear to be in complementary distribution, and which seem to all occur in the same order with respect to other M.S.E.s are grouped together.

Sentence functional type restricts the occurrence of Post-S M.S.E.s. Phrase structure rule (7.59) gives the composition of the Post-S of an assertative S.

If the indefinite time-of-evidence particle, kǐ .ap, occurs, no

(7.59)

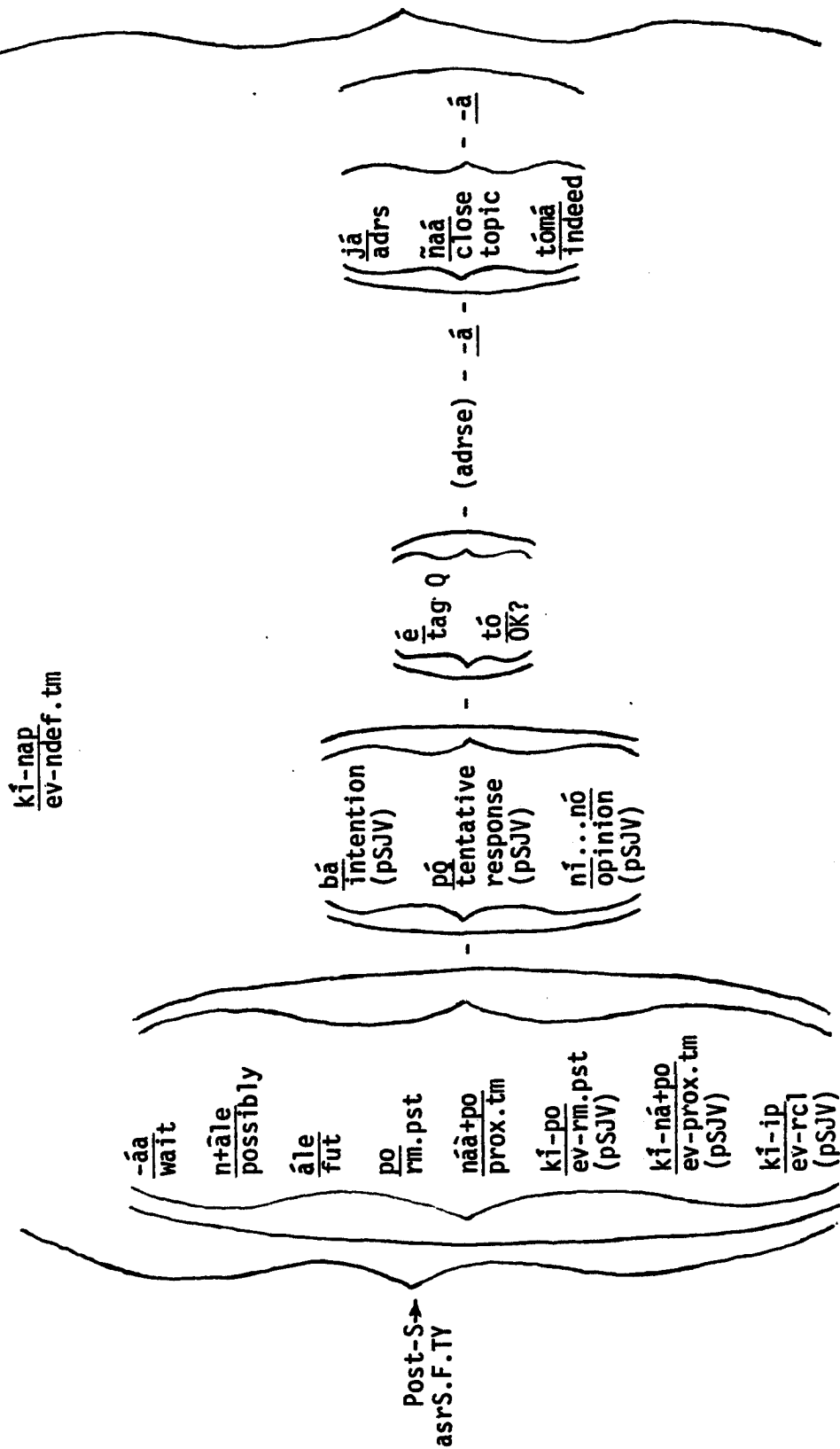

other M.S.E.s occur in the Post-S. If kí-nap does not occur, then -á must, but any other M.S.E.s are optional, except that the future particle, ále, is obligatory with the indefinite imperative, a fact not formalized here.

The first of the lower columns of M.S.E.s consists of time-related items, except for n+ále, 'possibly'. The middle two particles, po 'remote past', and náâ+po 'proximate time', indicate the time the sentence takes place. These have corresponding time-of-evidence particles, kí-po, 'remote past evidence', and kí-nâ+po 'proximate time evidence', which trigger pSV mood in the Aux stem by rule (6.63). The 'recalled evidence' particle, kí-ip, likewise requires pSV mood.

The particles kí-nap, kí-po, and kí-ip frequently occur in myth texts after the -á syntactic marker. In that case the utterance is considered to be formally a sentence fragment consisting of a quoted sentence followed by the particle, which indicates the story has been told before or is being recalled. A time-of-evidence particle indicates to the hearer when he encountered evidence bearing on the statement or question contained in the sentence. When pressed for a translation of these, informants sometimes say they mean, 'you know'.

The particles in the second of the lower columns in (7.59) qualify the sentence as something the speaker in some way thinks. They all require pSV mood and occur only in assertative sentences, according to the data at hand. When the particle nó 'opinion' occurs, the particle ní always immediately precedes the subject of the sentence:

(7.60)T eé-ve mi teé ní pa-zé-e-na kǐ
 that-pl use cont ? lpi-pSV+asr-th-lk again

ále nó
fut opinion

'We're going to do it again using those same things.'

The two particles in the third of the lower columns in (7.59) are sentence tags. Probably they can occur in a Post-S of any sentence functional type. There is no evidence that these actually form a set separate from the addressee items except that, unlike addressee items, they cannot be postposed behind -á. The addressee terms are an open class:

(7.61)

addressee →

{	//-éere//	}
	singular addressee	
	<u>maác</u>	
	plural addressee	
	kin term	
personal name		
etc.		

The bound syntactic marker, -á, is obligatorily introduced, though it may be deleted if nothing follows it. After this -á a rather heterogeneous set of particles occurs. If one of these occurs another -á occurs.

The composition of the Post-S in nonassertative Ss is given by phrase structure rule (7.62).

The first column in (7.62) contains time-related M.S.E.s. The top three items are unrestricted by sentence functional type. The lower five items are the nonassertative equivalents of the time and time-of-evidence particles which can occur in an assertative Post-S. The tags and addressee M.S.E.s are unrestricted by sentence functional

(7.62)

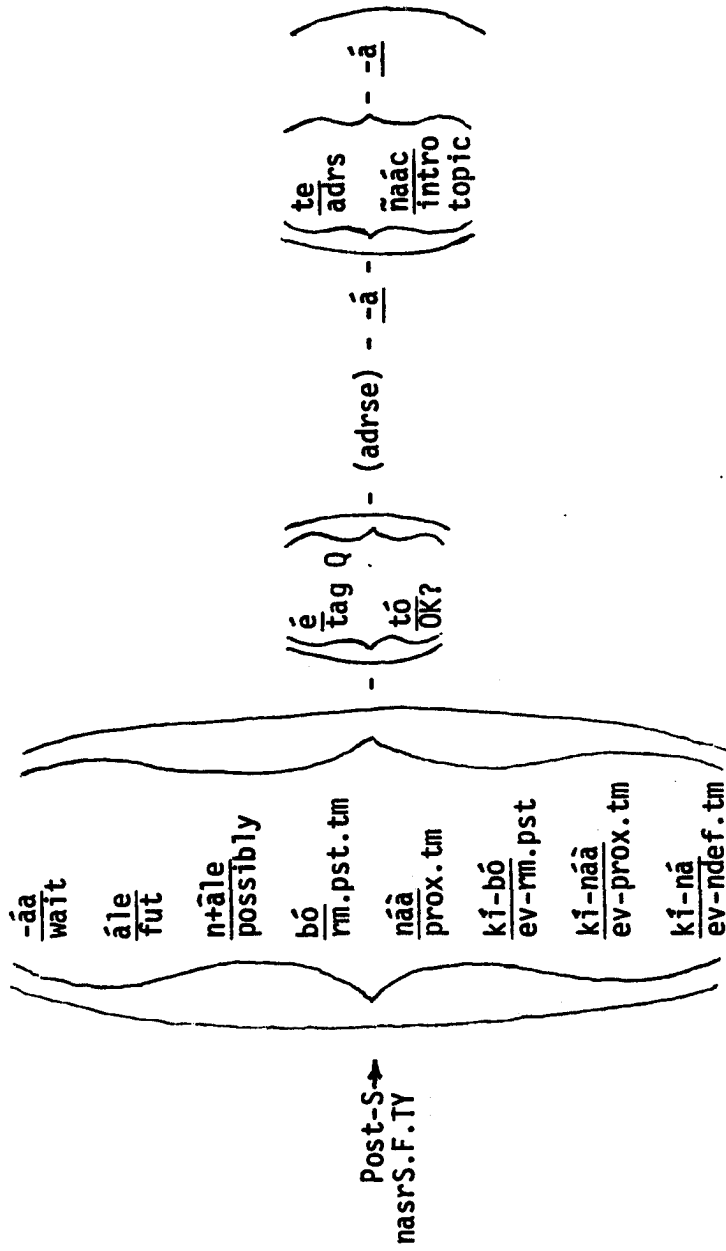

(7.63)

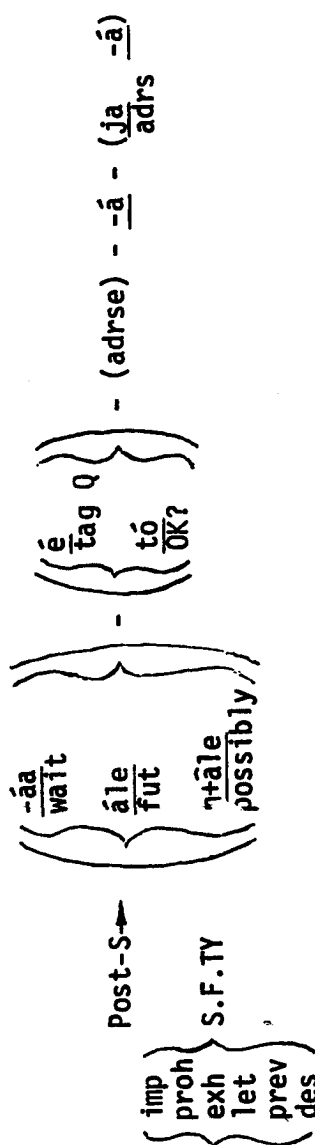

type. The two particles occurring after the syntactic marker, -á, seem to occur only in nonassertative Ss.

The composition of a Post-S of the rather uncommon imperative, prohibitive, exhortative, 'let', preventative, or desiderative sentence functional types cannot be determined from the data at hand. At least the time-related M.S.E.s -áá 'wait' and ále 'future', can occur in imperative sentences, as can the tags, the addressee items, and the syntactic marker -á. The address particle ja can occur in 'let' sentences. Rule (7.63) offers a very tentative hypothesis about the composition of Post-Ss of these sentence functional types.

7.8 Minor Transformations Involving the Post-S M.S.E.s

An addressee term is generated immediately before the first -á syntactic marker by the Post-S phrase structure rules given above.

Often it stays there:

(7.64)T á té alóp sé-ere
 where nasr he nasr-sg.adrse

'Where is he?'

However, an addressee term may be optionally postposed to a position behind all other M.S.E.s, except that a second -á syntactic marker may follow it. If an address particle, either ja or te, occurs, then this postposing is obligatorily:

(7.65)T pā-āt kāli tāga va-á je-ere
 lpi-let bone paste eat-s.m adrs-sg.adrse

'Let's eat marrow, Pal!'

Rule (7.66) moves the addressee term (affix, particle, kin term,

or whatever) to the rear, obligatorily if an address particle occurs:

(7.66) Addressee Postposing:

$$X - \text{addressee} - \underline{-\acute{a}} - \left(\left\{ \begin{array}{c} \underline{ja} \\ \underline{te} \end{array} \right\} \right) - (\underline{-\acute{a}})$$

$$\begin{array}{cccccc} 1 & 2 & 3 & 4 & 5 & \Rightarrow \\ 1 & & 3 & 4 & 2 & \end{array}$$

Condition: obligatory if 4 occurs; optional otherwise.

In example (7.65) above the syntactic marker -á has not been deleted since it is not the final element in the S. In example (7.64) above the -á was S-final and was (optionally) deleted. Whenever -á is nonfinal it must be retained, e.g. in quote constructions:

(7.67)T "jè tígí pí teé-á" máà-á
 that place from cont-s.m (3s)-pPST+asr-s.m

'"From there," he said.'

Phonosyntactic rule (7.68) optionally deletes -á if nothing follows it:

(7.68) -á Deletion:

$$\underline{-\acute{a}} \rightarrow \emptyset / _ \emptyset$$

Condition: optional

Application: Applies after (7.66), Addressee Postposing. Applies once per S.

It sometimes happens that one syntactic boundary marked by -á immediately precedes another syntactic boundary marked by -á. If the second -á is retained, an epenthetic á is inserted between the markers:

(7.69)T méne ká bó tá-mâà "tére-á" á-á
 that because tz 3p-pPST+asr really-s.m s.m

'It was because of that that they said, "Really?''

Phonosyntactic rule (7.70) inserts á between any two -á markers in immediate succession:

(7.70) á Epenthesis:

-á-á → -á á-á

Condition: obligatory

Application: Applies after rule (7.68), -á Deletion, as many times as possible within a S.

In sentence (7.69), for example, it is possible, though not preferred, to delete the final -á. In that case the epenthetic á does not appear. For this reason rule (7.70) is ordered after (7.68).

8.0 SUMMARY OF RULES

The formal syntactic rules which were presented in Sections 4.0, 5.0, 6.0, and 7.0 are summarized below. Rules which were superceded by revised versions of themselves are not included below. Rule numbers are given to the left, page numbers to the right.

8.1 Phrase Structure Rules

The phrase structure rules listed below are not a complete set since more are presented in Sections 9.0, 10.0, 11.0, and 12.0. Those are listed at the end of each section.

(4.1)	<u>S Composition</u>	39
(5.6)	<u>S' Composition</u> (revised).....	56
(6.61)	<u>Auxiliary Stem Feature Composition</u>	93
(7.2)	<u>Assertative Pre-S Composition</u>	101
(7.3)	<u>Nonassertative Pre-S Composition</u>	102
(7.4)	<u>Imperative, 'Let', Preventative, or Desiderative Pre-S Composition</u>	103
(7.5)	<u>Prohibitive or Exhortative Pre-S Composition</u>	104
(7.8)	<u>DemP Composition</u>	105
(7.31)	<u>Q Composition</u>	113
(7.59)	<u>Assertative Post-S Composition</u>	129
(7.61)	<u>Addressee Composition</u>	131
(7.62)	<u>Nonassertative Post-S Composition</u>	132
(7.63)	<u>Imperative, Prohibitive, Exhortative, 'Let', Preventative, or Desiderative Post-S Composition</u>	133

8.2 Insertions

The two informal insertion rules are mutually exclusive.

(7.33) <u>WH Insertion</u>	115
(7.36) <u>Discourse Pronoun Insertion</u>	116

8.3 Transformational Rules

There appears to be no need to apply the transformations and phonosyntactic rules in cyclic fashion. However, there are some ordering relationships--cases where a S must undergo any application(s) of one rule before another rule is applied. These are indicated by arcs connecting rules below.

The transformational and phonosyntactic rules generally apply only once per S. However, rule (7.70) can apply repeatedly to an S, and rules (6.64), (7.37), and (7.38) can apply more than once per S, though only once per S'. Most rules are intrinsically limited to one application, but rules (7.38) and (7.68), as written, must be extrinsically limited to one application. The rules which can move lexical items, rules (7.37), (7.38), (7.45) and (7.66), are all obligatory under some conditions and optional under other conditions. All other rules are obligatory except (7.68), which is always optional.

(6.63) <u>Mood and Aspect Adjustment</u>	95
(6.64) <u>Auxiliary Stem Person Prefix S.I. Value Assignment</u>	96
(7.37) <u>Predicate NP Preposing within S'</u> (revised).....	117
(7.38) { <u>VP, S', S'-á</u> } <u>Preposing within S'</u> (revised).....	118
(7.45) <u>Preposing into S</u>	121
(7.52) <u>Scope Marker Placement</u>	125
(7.57) <u>Topicalization Particle Attachment</u>	127
(7.58) <u>Third Person Singular Insertion</u>	127
(7.66) <u>Addressee Postposing</u>	135

8.4 Phonosyntactic Rules

The phonosyntactic rules must follow transformational rule (7.66).

(7.68) <u>-á Deletion</u>	135
(7.70) <u>á Epenthesis</u>	136

9.0 NOUN PHRASES

A noun phrase is defined as any syntactic unit or construction which can occur before the auxiliary stem as the subject of a clause or which can occur as a direct object before a transitive verb stem and which is not a person prefix. All NPs, and only NPs, can be verbalized with the particle ná.

9.1 Qualification Particles

There are six particles which occur after NPs, qualifying them in some way. These are listed below with glosses.

- (9.1) pátpát 'contrast'
 teé 'continuing, too, still, throughout'
 tere 'real, genuine'
 téét 'exact, just'
 té-teé 'only' (<téét 'exact' + teé 'continuing')
 vé-téét 'same, equal' (<ve 'it' + téét 'exact')

Examples of qualification particles modifying NPs in sentences:

- (9.2)T eé ká bō pa-máge-é-na koño-ót ąza pátpát
 that in tz lpi-asr-th-lk dig-dm paca contrast

ake-é-na
 kill-th-lk

'Paca (as opposed to other animals) we kill by digging there.'

- (9.3)T eé téét té eé-na zāān-ééc teé
 then exct nasr th-lk warrior-pl cont

jā-ka bāckít kac
 pPST+nDEF+uDUR+nasr-go squirrel involve

'Then still (more) warriors arrived like that with Squirrel?'

(9.4)T ñã sep pére-kōlo té-teé māga
 that lf.o (=photo) nature-devoid only asr

'There's only those photos with no one in them.'

These six qualification particles occur after VPs and DemPs also. After VPs two successive qualification particles often occur in text examples. Informants readily accept two or more qualification particles after NPs, and I shall assume that there is no limit in principle on their number. The particle té-teé 'only' is never followed by other qualification particles in text examples.

In example (9.4) té-teé appears to qualify the whole preceding NP. The resulting construction itself satisfies the definition of a NP. Its constituent structure is diagrammed in (9.5):

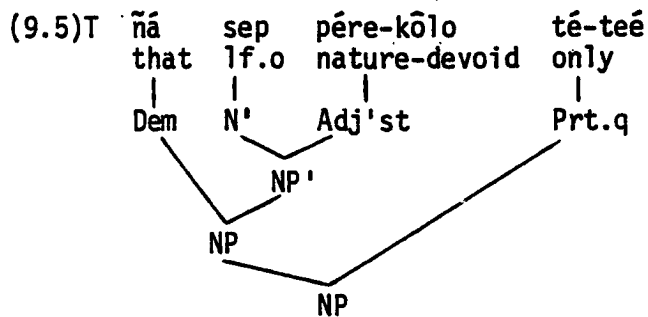

Rule (9.6) applies recursively, generating NPs containing successive qualification particles, each modifying the entire preceding NP:

(9.6) NP → NP - Prt.q

9.2 Demonstratives

Demonstratives form a closed set of words. A demonstrative can modify a following NP' and can also occur as a minimal NP. The set

of demonstratives is divided into those which indicate proximity in space or time (pPROX) and those which don't (nPROX). The pPROX demonstratives (the first five in (9.7) below) can occur in sentence-initial demonstrative phrases.

(9.7) Demonstratives:

ǵá	'this', proximate to first person(s)
jè	'that', proximate to second or third person(s)
ñá	'that, remote', not proximate to first or second person(s)
eé	'that', proximate to understood situation
ǵ	'which', proximate to questioned situation
má	'some, other', indefinite
náapó	'that, past'

In the text examples below each underlined demonstrative modifies a following NP':

(9.8)T "eé ká bó máã . 'e-béré e-népo-teè
 that in tz (3s)-pST+asr 2s-exh 2s-arm-flow (=shoot)

jè alimé-èc kaj-á' kaj-á" kí-ip
 that black+monkey-pl involve-s.m (3s)-involve-s.m ev-rc1

'At that he said to him, "Shoot for those black monkeys."'

(9.9)T ñá pa-gár-ábi ká kǵ
 that lpi-sun-face in again

'On that day of ours again.' (sentence fragment referring to a festival planned for Brazil's Day of the Indian)

(9.10)T "'ǵ té náapó me-sérat pǵǵí sá-á" bó
 which nasr that+past 2p-nephew young nasr-s.m tz

mága-á ja-á' máã tá-sérat kǵâc kaj-á"
 1s+asr-s.m adrs-s.m (3s)-pST+asr 3p-uncle old involve-s.m

kī-ip
ev-rcl

'"Where is that young nephew of yours?' I ask you," he said to an old uncle of theirs.'

Diagram (9.5) above illustrates the position of a demonstrative in a NP when the demonstrative modifies a NP'. Rule (9.11) alters rule (9.6) above so as to also generate NPs composed of NP's optionally modified by demonstratives:

$$(9.11) \quad NP \rightarrow \left\{ \begin{array}{l} NP - \text{Prt.q} \\ (\text{Dem}) - NP' \end{array} \right\}$$

9.3 NP's

A NP' is a NP exclusive of its optional demonstrative and qualification particles. It consists of the head of the NP and any following adjective stems. This is illustrated in diagram (9.5) above.

9.3.1 Adjective Stems

Adjective stems follow the head of a NP and modify it; they cannot constitute minimal phrases by themselves. When noun stems are prefixed for person the head of the resulting construction is the stem, but when adjective stems are prefixed for person the head of the construction is the person prefix:

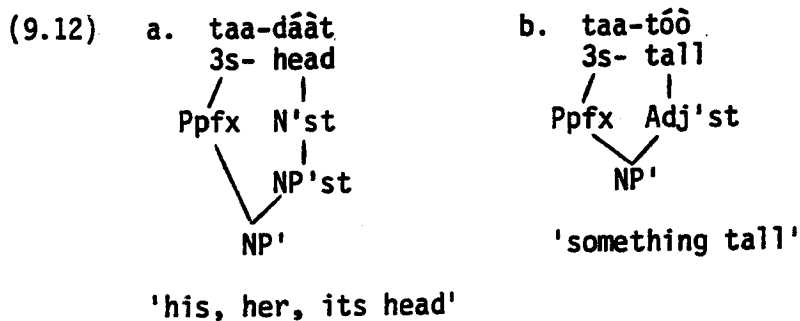

The third person singular adjective stem prefix is indefinite ('something'), as in (9.12b) above. The third person plural prefix can be indefinite, as in (9.13). The first person plural inclusive prefix can be generically human, as in (9.14).

(9.13)T tā-sot pa-māā aanā
3p-bad 1pi-pCOP+asr now

'We're no good now.'

(9.14)T "pa-bocōdc pátāā pē-a kólólóok vīri
1pi-thin chest flat-ish skinny walking+dm

tā-sop máā tá-kalā-p koj-ā" kī-po-ā ñāā
3p-father pCOP+asr 3p-want-nz at-s.m ev-rm.pst-s.m end+topic

'Their fathers were going around skinny and sunken-chested, missing them.'

Locative adjective stems (such as vīri 'walking' in (9.14) above) always follow nonlocative adjective stems when both occur:

(9.15)T "'jè tígi ó-ma-áló alé-ec pópit sōt
that place 1s-pPST+asr-come 3s-pl target putrid

a'ííit tá ále gaáj-á' máā
lying+down+dm with explanation mother-s.m (3s)-pPST+asr

a-ti kaj-á" kī-ip
3c-mother involve-s.m ev-rcl

'"I'm bringing their game (which was) lying putrid (on the ground), Mother," he said to his mother.'

I shall assume that there is no limit in principle on the number of adjective stems which can occur after the head of a NP' and that the constituent structure of NPs containing adjective stems such as those in (9.14) and (9.15) above is as given in (9.14a) and (9.15a) below. Notice the complex adjective stem (Adj st) in (9.14a).

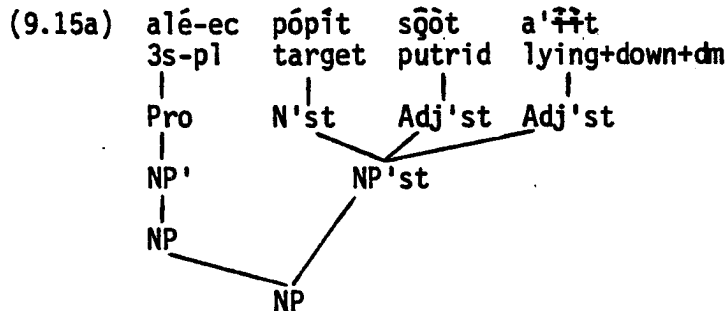
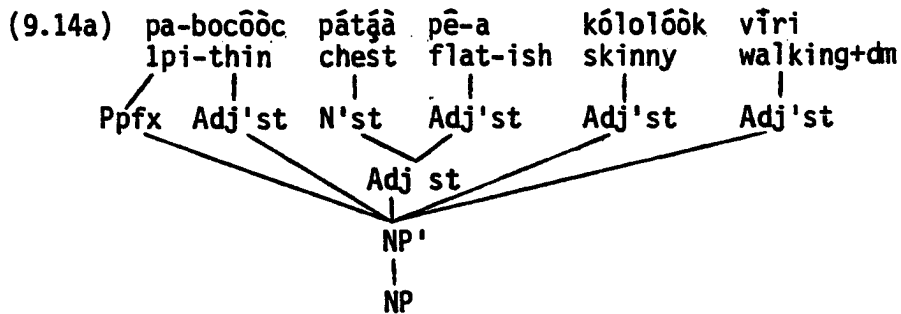

Some adjective stems show no change in form whether they are singular or plural:

- (9.16) vôôp 'red'
pôtôô 'seated, heaped up'

Others show differences in form due to suppletion, suffixation, or lack of stem formative final syllable lengthening. These distinctive aspects of adjective stem morphology are described in Appendix B. Plural adjective stems can only modify plural nominals or plural person prefixes. Examples of form changes:

(9.17)	Singular	Plural	Gloss
	cîciîit	cîik	small
	pôoc	tâk	big
	atôô	tó-ló	tall, long

Singular	Plural	Gloss
patîi	patî-rî	heavy
kãñãp	kãñãp	crooked
pétãc	pétãc	bent over

A few locative adjective stems are inflected for plural times,
e.g.:

(9.18)	Singular Times	Plural Times	Gloss
	a'ãât	a'ar-êêt	lying down
	abãã	abã-lêêt	suspended

The singular/plural and singular/plural times concord between adjective stems and the nominal heads which they modify will not be formalized.

9.3.2 NP's Which Are Possessed NP' Stems

Some NP's are composed of a possessor constituent and a possessed NP' stem (NP'st). The possessor may be a person prefix or a NP. A NP'st is composed of an elementary or complex noun stem and any immediately following adjective stems, which modify it.

Each Gavião elementary noun stem (N'st), complex noun stem (N st), or NP'st has values for four 'nominal construction type' subcategorization features which determine the possible relations it may have with a preceding nominal expression. Four two-valued (plus or negative, p or n) features are postulated:

INAL 'inalienably possessed by the preceding nominal'

ALN 'alienably possessed by the preceding nominal (providing it is capable of control--usually animate)'

MOD 'modified by the preceding nominal'

ARG 'takes the preceding nominal as its argument'

The features and values have morphological correlates. The feature values of a complex noun stem or a NP' stem are those of its left-most constituent elementary noun stem. Nominal stems which are pMOD or pARG form compound complex words or compound complex word stems with the preceding nominal expression. These are not involved in possessive constructions; they are discussed in Section 12.0.

A nominal stem (for example, a pARG noun stem) can be both nINAL and nALN, so both of these features are needed. All possessed NP' stems are either pINAL, in which case they are inalienably possessed, or pALN, in which case they are alienably possessed. Very rarely pINAL or pALN elementary noun stems form compound complex nouns or noun stems with a preceding noun or noun stem.

Inalienable possession is illustrated in (9.19) below. Only relevant, nonpredictable features are indicated.

(9.19)A Inalienable Possession:

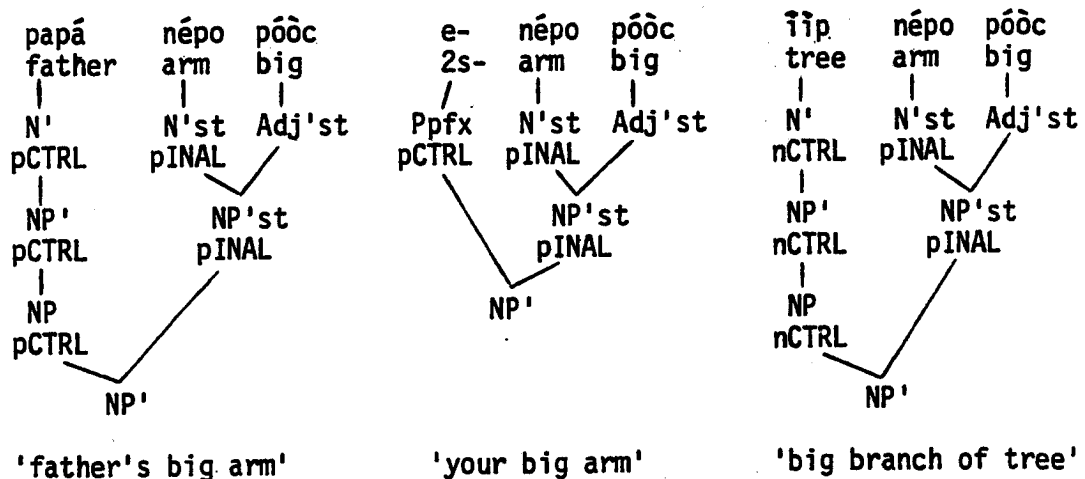

Alienable possession is illustrated in (9.20) below. Example

(9.20c) is not a NP' containing a possessor, but rather a NP' whose head is a compound complex noun formed by a noncontrol (nCTRL) elementary noun modifying a pMOD (also pALN) elementary noun stem. Such constructions are discussed in Section 12.0.

(9.20) a. Alienable Possession:

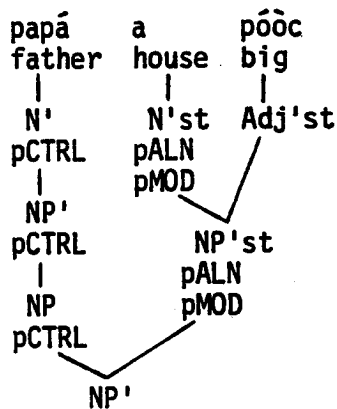

'father's big house'

b. Alienable Possession:

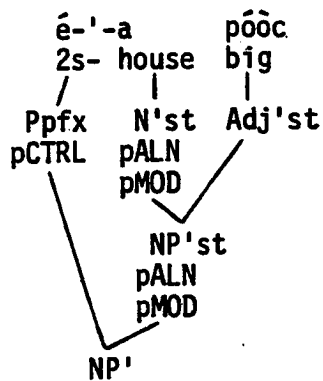

'your big house'

c. Compound Complex Noun as NP' Head:

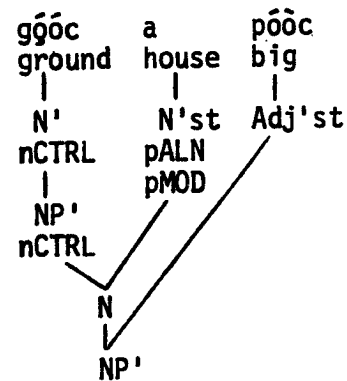

'big house with a dirt floor'

Elementary or complex noun stems which are pINAL (inalienably possessed) are negative for the other three nominal construction type features: nALN, nMOD, and nARG. The pINAL noun stems have no corresponding noun and do not accept the 'w' prefix which derives words from word stems; they are always possessed by an immediately preceding NP or person prefix, as in (9.19). The possessor may be capable of control or not (p or n CTRL), but there is always an inherent possessive or part/whole relationship, as shown in (9.19). Noun stems which are pINAL may belong to any of the four person prefix classes. Some examples of pINAL elementary noun stems are given below in (9.21). The initial syllable of //e-// and //eé-// class stems always has high tone in postnominal form whatever its tone in the base form.

(9.21)	N'st pINAL	(postnominal form)	2s-N'st pINAL	N'
sweetheart	cj̄p		ɛ̄-jj̄p	(none)
foot	pí		ɛ̄-bí	
blood	cīt		ɛ̄-jīt	
mother	ti		ɛ̄-di	
front	ába		ɛ̄é-ba	
face	ábi		ɛ̄é-bi	
penis	aá		éè-'-aá	
sister	paàt		ɛ̄è-baàt	

Unlike pINAL noun stems, pALN (alienably possessed) stems can only be possessed by pCTRL (generally, animate) NPs or person prefixes. In (9.20a) and (9.20b) the noun stem, a 'house' or 'village', is possessed since the preceding NP or person prefix is pCTRL. However, in (9.20c), a is modified by gôóc 'ground', not possessed, since 'ground' is not capable of control. Notice that the adjective stem pôóc 'big' modifies the whole compound complex noun, gôóc a.

Alienably possessed elementary or complex noun stems always have corresponding nouns. They are negative for the features INAL and ARG, but they either (1) are derived from nouns which have corresponding pMOD noun stems or (2) are pMOD themselves.

The first type of pALN noun stem is derived from nouns by the prefix má-. The derived stem is pALN but nMOD. That is, it is always alienably possessed, never modified, by a preceding nominal expression. The noun from which it is derived always has a corresponding, phonetically identical noun stem which is nALN but pMOD. For example, the noun áv+l̄ 'dog' has a corresponding nALN, pMOD noun stem, áv+l̄

(which can be modified) and a derived pALN, nMOD noun stem, má-'-áv+i (which is alienably possessed). More examples:

(9.22)	N'st pALN nMOD	(postnominal form)	2s-N'st pALN nMOD	N' and N'st nALN pMOD
snake	má-bac		e-má-bac	bac
tatoo	má-jóli		e-má-jóli	jóli
fire	má-pó-kâc		e-má-pó-kâc	pó-kâc
tree	má-'-îip		e-má-'-îip	îip

The second type of pALN noun stem is also pMOD. This type has a corresponding noun which is phonetically identical with the noun stem if the stem is of the //é-// or //eé-// prefix class. For example, ado 'three-cornered basket' is an elementary noun stem which is pALN, pMOD and is also an elementary noun. If the noun stem is of the //e-// prefix class then the corresponding noun is formed with the 'w' word-forming prefix. For example, tábe 'axe' is a noun stem which is both pALN and pMOD. The corresponding noun is dábe 'axe'. No pALN, pMOD noun stems belong to the //éè-// prefix class. Examples:

(9.23)	N'st pALN pMOD	(postnominal form)	2s-N'st pALN pMOD	N'
machete	típe		é-dípe	dípe
Brazil nut	mâàm-gâap		e-mâàm-gâap	maàm-gâap
vapor	djk		é-djk	djk
house	a		é-'-a	a
hammock	îni		eé-ni	ini
arrow	ájáp, íjáp		éé-jáp	jáp (irreg.)

Phrase structure rule (9.26) generates NP's composed of possessed NP' stems, covering both inalienable and alienable possession. In the latter case the possessor, whether person prefix or NP, is pCTRL.

$$(9.26) \quad \text{NP}' \rightarrow \left\{ \begin{array}{l} \left\{ \begin{array}{l} \text{Ppfx} \\ \text{NP} \end{array} \right\} - \text{NP}'\text{st} \\ \left\{ \begin{array}{l} \text{Ppfx} \\ \text{NP} \\ \text{pCTRL} \end{array} \right\} - \text{pINAL} \\ \left\{ \begin{array}{l} \text{Ppfx} \\ \text{NP} \\ \text{pALN} \end{array} \right\} - \text{NP}'\text{st} \\ \left\{ \begin{array}{l} \text{Ppfx} \\ \text{NP} \\ \text{pCTRL} \end{array} \right\} - \text{pALN} \end{array} \right\}$$

Phrase structure rule (9.27) generates NP' stems consisting of an elementary or complex noun stem followed by zero or any larger number of adjective stems, any of which may be elementary or complex. The alpha notation stipulates that the NP' stem has the same nominal construction type feature values as those of its elementary or complex noun stem.

$$(9.27) \quad \begin{array}{l} \text{NP}'\text{st} \rightarrow \\ \alpha \text{INAL} \\ \beta \text{ALN} \\ \gamma \text{MOD} \\ \delta \text{ARG} \end{array} \left\{ \begin{array}{l} \text{N}'\text{st} \\ \text{N st} \\ \alpha \text{INAL} \\ \beta \text{ALN} \\ \gamma \text{MOD} \\ \delta \text{ARG} \end{array} \right\} - \left\{ \begin{array}{l} \text{Adj}'\text{st} \\ \text{Adj st} \end{array} \right\}^*$$

9.3.3 NP's Containing No Possessor

NP's which contain no possessor contain no NP' stems. Their head is an elementary or complex noun, a pronoun, a demonstrative, or a person prefix. If the head is a person prefix, then it must be modified by one or more elementary or complex adjective stems; otherwise adjective stems modifying the head are optional. Examples of NP's with N', N, and person prefix heads are diagrammed in (9.5),

(9.20c), and (9.14a), respectively, above. Examples of NP's with person prefix, pronoun, and demonstrative heads are given below (head underlined>):

(9.28)T mát ká bó tá-kâc pótóò mé-e-na
 that in tz 3p-roasted heaped+up pPST+asr-th-1k
 tá-pére ká
 3p-nature in

'There there were heaps of roasted (meat) in that manner of theirs.'
 (The ancestors roasted piles of meat.)

(9.29)T alóp ábíí cāât abāâ-á
 3s with+face+lowered hanging suspended-s.m

'Him hanging upside-down.' (sentence fragment describing the Giant Lizard)

(9.30)T "jè té-teé aka èt kára-ále-á'
 that only kill 2s-(pDEF+imp) yet-fút-s.m
 máâ kaj-á" kí-ip
 (3s)-pPST+asr (3s)-involve-s.m ev-rcl

'"Just kill that (one)," he said to him.'

Phrase structure rule (9.31) generates NP's which contain no possessor.

(9.31)

$$NP' \rightarrow \left\{ \begin{array}{l} \left\{ \begin{array}{l} N' \\ N \\ Pron \\ Dem \end{array} \right\} \\ Ppfx \end{array} \right. - \left\{ \begin{array}{l} \left\{ \begin{array}{l} \text{Adj}'st \end{array} \right\}^* \\ \text{Adj st} \\ \left\{ \begin{array}{l} \text{Adj}'st \end{array} \right\}^+ \\ \text{Adj st} \end{array} \right.$$

A nonprefixal NP' head is followed by zero or any number of elementary or complex adjective stems (as indicated by the star).

A person prefix NP' head is followed by one or any larger number of elementary or complex adjective stems (as indicated by the plus).

9.3.4 Pronouns

Pronouns occur only as heads of NP's, unlike demonstratives, which can modify NP's. Unlike elementary nouns, pronouns have no corresponding stems and constitute a small, closed set.

(9.32) Pronouns:

gòt	first person singular
èt	second person singular
(taàc)	third person singular
jì	third person singular, mildly honorific
alóp	third person singular
panóóc	first person plural inclusive
tqóóc	first person plural exclusive
menóóc	second person plural
tqác	third person plural
jī-ìc	third person plural, mildly honorific
alé-ec	third person plural
ve	abstract inanimate, 'it'
mé	interrogative, 'who, what'
mát	substantive discourse pronoun, 'this, these, that, those, he, she, it'
mā-àc	animate plural substantive discourse pronoun, 'they'
méne	nonsubstantive discourse pronoun, 'this, that, it'

When a person pronoun occurs instead of the much more common person prefix the person is emphasized:

(9.33)T ǫ̀o panṑc sǎ eé-na sa-ga kí-nap
 neg 1pí pSJV+asr th-1k 3s-kill ev-ndef.tm

'WE don't hunt like that.'

Certain aspects of the usage of third person pronouns are unclear. Some informants claim that taàc 'third person singular' is acceptable as a subject, direct object, or possessor; others deny this. There is only one text example of it:

(9.34)T taàc bóg-ǎ
 3s tz-s.m

'It's him.'

The third person singular pronoun jì is phonologically anomalous in that, like the demonstrative jè 'that, near second or third person(s)', its tone is short and rising before nonhigh tones, short and low otherwise. It is mildly honorific and used only for humans or quasi humans such as animals in myths. Its plural, jí-íc, contains the animate plural suffix, // -éèy //.

The common third person singular pronoun alóp is phonologically anomalous in that its second syllable is the only short high tone in the language which downsteps immediately following high tones to mid. Its plural, alé-ec, contains the animate plural suffix. The pronoun alóp seems to emphasize person less than the other person pronouns:

(9.35)T "eé pí bó alóp ma-káá alóp ákinì
 that after tz 3s pPST+asr-go 3s see

kǐ-ǎ" kǐ-ip
 again-s.m ev-rcl

'After that he went to see him again.'

Occasionally alóp or alé-ec are pragmatically first or second person though formally third person:

(9.36)T bó té alóp éèt aa-co ákinĩ
 already nasr 3s pPST+pDEF+nasr 3c-photo see

kĩ-nā
 ev-ndef.tm

'Did you already see your photo?'

Notice that in (9.36) 'photo' is prefixed for coreferentiality with a third person, not second person, subject.

The abstract inanimate pronoun ve refers to a state of affairs, not an object:

(9.37)T "á-na té táãñ-ê-na ve
 which-lk nasr 3p-(pPST+pDEF+nasr)-th-lk it

māga-ā" tó-māā tā-kac
 do-s.m 1pe-pPST+asr 3p-involve

'"How did they do it?" we asked them.' (asking about a homicide)

The discourse pronouns, māt and méne, are discussed in Section 7.4 above. The interrogative pronoun, mé, is discussed in Section 7.3 above.

9.4 Appositions

Very few appositive constructions occur in texts. In the few examples observed, the more descriptive term, a common noun, precedes the less descriptive term, a proper noun:

(9.38)T padágèè jipo tíĩg-íft
 old+man w+point speckled-ish+dm (=Coatimundi's nickname)

'Old Man Speckled Beak'

There are too few examples to determine the structure of appositive constructions, and these will not be included in the NP composition rules.

9.5 Summary of NP Rules

The phrase structure rules presented in Section 9.0 are listed together below:

$$(9.39) \quad NP \rightarrow \left\{ \begin{array}{l} NP - \text{Prt.q} \\ (\text{Dem}) - NP' \end{array} \right\}$$

$$NP' \rightarrow \left\{ \begin{array}{l} \left\{ \begin{array}{l} \text{Ppfx} \\ NP \end{array} \right\} - \begin{array}{l} NP'st \\ pINAL \end{array} \\ \left\{ \begin{array}{l} \text{Ppfx} \\ NP \\ pCTRL \end{array} \right\} - \begin{array}{l} NP'st \\ pALN \end{array} \\ \left\{ \begin{array}{l} N' \\ N \\ \text{Pro} \\ \text{Dem} \end{array} \right\} - \begin{array}{l} \{Adj'st\}^* \\ \{Adj\ st\} \end{array} \\ \text{Ppfx} - \begin{array}{l} \{Adj'st\}^+ \\ \{Adj\ st\} \end{array} \end{array} \right\}$$

$$NP'st \rightarrow \left\{ \begin{array}{l} N'st \\ N\ st \end{array} \right\} - \begin{array}{l} \{Adj'st\}^* \\ \{Adj\ st\} \end{array}$$

α INAL
 β ALN
 γ MOD
 δ ARG

α INAL
 β ALN
 γ MOD
 δ ARG

10.0 VERB PHRASES

A verb phrase is defined as any syntactic construction which is potentially subject to the VP, S', S'-á preposing rule and which is not a S' or S'-á. A VP can be distinguished from a S' or S'-á by the fact that a S' node immediately dominates an auxiliary stem, whereas a VP node does not. All VPs can be nominalized with the derivational particles mát and méne. The negative particle, qôp, occurs after VPs and probably occurs after any VP under the right semantic circumstances. The intensification particle, kîi, can occur after any VP.

There are three types of VPs: (1) transitive VPs, (2) cross-referencing VPs, and (3) VPs composed of a verb. An elementary verb stem is defined as an elementary word stem which can be the head of one of the first two types of VPs. That is, a VP can consist of an elementary transitive verb stem (V'st.t) preceded by a NP or person prefix, or it can consist of an elementary cross-referencing verb stem (V'st.c) preceded by a cross-referencing person prefix. These two types of elementary verb stems are mutually exclusive: an elementary transitive verb stem cannot also be an elementary cross-referencing verb stem, nor vice versa.

An elementary verb (V') is defined as an elementary word which can be a minimal VP by itself. Elementary verbs and elementary verb stems are mutually exclusive categories.

A small minority of elementary transitive verb stems are inherently marked for singular or plural object. A small minority of elementary cross-referencing verb stems are inherently marked for singular or plural subject. A few elementary verbs, such as kîrîñáá 'all',

require a plural NP or person prefix somewhere in the sentence.

A few elementary verb stems, both transitive and cross-referencing, mark plural action (times) by suppletion:

(10.1)	Singular Action:	Plural Action:
V'st.t:	íǵí remove+sg.X	pirí remove+pl.X
	pegè break+sg.X	pea break+pl.X
V'st.c:	kaā go+sg.X	málǵ go+pl.X

Any elementary verb stem or verb which ends in a long open syllable may be marked for plural action by the suffix // -rV//:

(10.2)	Unmarked:	Plural Action:
V'st.t:	abiǵ kill+pl.o	abi-ri kill+pl.o-pl.X
V'st.c:	pakoò awaken	pako-lo awaken-pl.X
V':	gakoráá hunt	gakorá-la hunt-pl.X

Informants are sometimes uncertain whether the plurality of a verb stem is plural action or plural object or subject, saying only that it means 'a lot'. Number concord is not formalized in the syntactic rules.

10.1 Qualification Particles in Verb Phrases

The six qualification particles which occur after NPs can also occur after VPs: pátpát 'contrast', teé 'continuing', tere 'real, genuine', téét 'exact(ly)', té-teé 'only', and vé-téét 'same'. Two

others occur after VPs but not after NPs:

- (10.3) *kíî* 'intensification, a lot, many times'
 ôòp 'negative'

The intensification particle, *kíî*, seems to imply plural action, but this isn't entirely clear. The verb or verb stem which is the head of a VP modified by *kíî* is usually marked for plural action, providing that it can be so marked by suppletion or suffixation:

- (10.4)T *ci-ko-e* *málakálá* *teé* *kíî* *kí-nap*
 3s-word-pl follow+pl.X cont ints ev-ndef.tm

'Repeating his words a lot.' (sentence fragment)

The negative particle, *ôòp*, negates individual VPs:

- (10.5)T "gakoráá *ôòp* *máá* *a-vit* *aka* *ôòv-á*"
 hunt neg (3s)-pPST+asr 3c-food kill neg-s.m
kí-po-á
 ev-rm.pst-s.m

'He didn't hunt, didn't kill food for himself.'

This particle cannot be prefixed for person, but the related adjective stem, *ôòp* 'nonexistent', can be.

There is a particle, *cík* 'somewhat, a bit', which is possibly a qualification particle, though this is not certain. It occurs after verbs and probably after verb stems:

- (10.6)T *óójá* *cík* *kí-gáre*
 rest somewhat again-yet

'(He's going) to rest a bit.' (sentence fragment)

This particle also occurs after adjective stems but not after

nouns, so it may not modify the whole preceding phrase as qualification particles do.

The order of the qualification particles after VPs appears to be variable except that in text examples té-teé 'only' is always last if it occurs. In (10.4) above, teé precedes kíi, but in (10.7) below the reverse is true:

(10.7)T "me-já+ká paágá kíi teé mee-kaà-p koc
2p-nDEF+nDUR+proh (3s)-open ints cont 2p-go-nz on

kára-ále-á" máã tá-kaj-á
yet-fut-s.m (3s)-pPST+asr 3p-involve-s.m

'"Don't open it on your trip," he told them.'

I shall assume that a construction composed of a VP and a qualification particle is itself a VP which likewise can be further modified by successive qualification particles. The structure of the VP in (10.4) above is then as given in (10.4a):

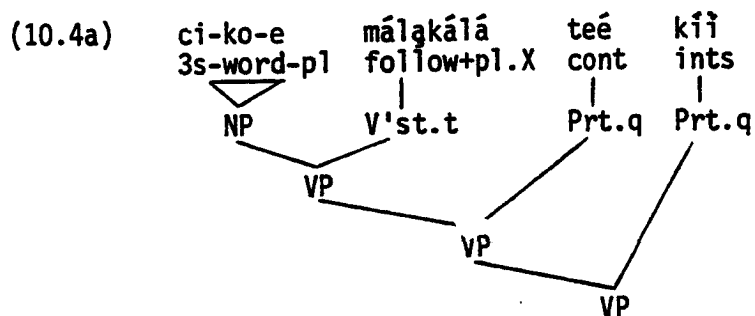

'repeating his words a lot'

Phrase structure rule (10.8) generates VPs modified by qualification particles:

(10.8) VP → VP - Prt.q

10.2 Transitive Verb Phrases

The third person singular prefixes of transitive verb stems may indicate a definite third person object ('him, her, it') or some indefinite object:

- (10.9) kalà 'want him, her, it, or something'
 (3s)-want
- taa-tíni 'care about him, her, it, or something'
 3s-care+about

The relatively few transitive verb stems which take only plural objects do not accept singular person prefixes:

- | | | | |
|---------|--------------------------|--------------------------|--------------------------|
| (10.10) | 2s-V'st.t: | 2p-V'st.t: | *2s-V'st.t: |
| | <u>éè-ka</u> | <u>mee-bii</u> | * <u>éè-bii</u> |
| | 2s-kill+sg.o | 2p-kill+pl.o | 2s-kill+pl.o |
| | 'kill you, sg.' | 'kill you, pl.' | 'kill you, sg.' |
| | <u>e-dígi</u> | <u>mee-kíí</u> | * <u>éè-kíí</u> |
| | 2s-knock+down+sg.o | 2p-knock+down+pl.o | 2s-knock+down+pl.o |
| | 'knock down
you, sg.' | 'knock down
you, pl.' | 'knock down
you, sg.' |

According to informants, singular object transitive verb stems such as aka 'kill, singular object', or tígi 'knock down, singular object', should not accept plural person prefixes, but this is not always adhered to. Nouns and noun stems are not marked for singular or plural unless they are animate, in which case the plural form is marked with the animate plural suffix, // -éèy //.

In transitive VPs an object NP or person prefix precedes an elementary or complex transitive verb stem. Examples with the transitive VPs underlined:

(10.11)T "eé téét paa-jaàc máà aa-kaà-p ná,
 then exct lpi-ancestor pPST+asr 3c-go-nz vz

pavé-èc kṛṛc tígí kii-á" kii-po-á
 thing-pl roasted+dm cause ints-s.m ev-rm.pst-s.m

'Back then our ancestor, before traveling, was roasting creatures.'

(10.12)T palíri pā-a má-'-éèc kac máa eé-na
 (3s)-share lpi-asr other-pl involve (3s)-put th-lk

'We share it putting it (forth) for others.' (sharing chicha)

The structure of the transitive VP in (10.11) and of the first transitive VP in (10.12) are diagrammed in (10.11a) and (10.12a) below:

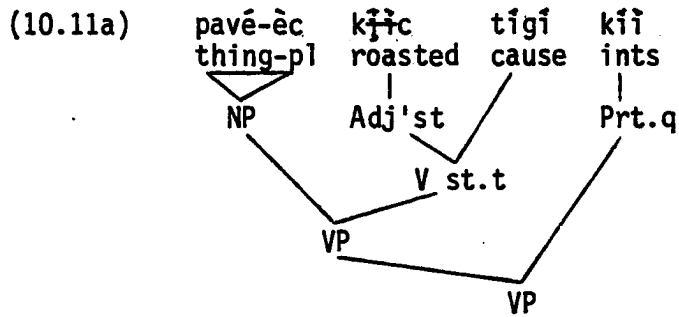

'roast creatures a lot'

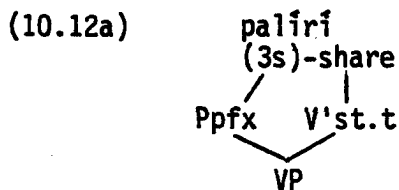

'share it'

Phrase structure rule (10.13) generates transitive VPs.

(10.13) $VP \rightarrow \left\{ \begin{array}{l} \text{Ppfx} \\ \text{NP} \end{array} \right\} - \left\{ \begin{array}{l} \text{V'st.t} \\ \text{V st.t} \end{array} \right\}$

There are about sixteen verb stems which translate as English prepositions. Some examples with second person singular prefixes:

(10.14)	ę-gābi	'(be) for you, benefactive'
	kā	'(be) in, because' (no person prefixes)
	ęé-bīri	'(be) below you'
	ęé-dāt	'(be) your size'
	ę-gac	'involve you'
	é-mi	'use you, instrumental'
	ęè-bí	'(be) on your side, from you'
	ęè-dāra	'(be) above you'

These verb stems are morphologically irregular in that they do not show the $//-\overset{\alpha}{V}//$ stem formative vowel reduplication (see Appendix B) which is usual for verb stems. Compare the examples in (10.14) with the transitive verb stems in (10.15), also given with second person singular prefixes:

(10.15)	e-'-ólo-paā	'eat up your food'
	ę-bāñá	'tickle you'
	ęé-gá-mapáá	'alight on you'
	eé-kinì	'see you'
	ę-bicāá	'wash you'
	ę-gamáá	'measure you'
	éè-tíní	'care about you'
	ęè-jálá	'leave you'

Stems such as those in (10.14) are considered postpositional transitive verb stems rather than a separate class of stems because

a phrase formed by one of them and its preceding person prefix or NP (1) distributes and moves like any other VP, (2) can be nominalized and negated like any other VP, and (3) cannot modify a nominal expression; for example, there is no direct Gavião equivalent for the English phrase 'the man in the house'.

10.3 Cross-referencing Verb Phrases

Elementary cross-referencing verb stems are intransitive. A few of them are inherently marked for plural or singular subjects. Informants prefer that these take only plural or singular person prefixes, respectively, though this is not always observed in practice, possibly because of some semantic fuzziness between plural subject and plural action. Examples:

(10.16)	2s-V'st.c:	2p-V'st.c:
	ee-gaã	me-vaḷã
	2s-go+sg.s	2p-go+pl.s
	'you, sg., go'	'you, pl., go'
	ee-viḥ	mee-paã
	2s-die+sg.s	2p-die+pl.s
	'you, sg., die'	'you, pl., die'

All cross-referencing elementary verb stems of the //é-// and //êè-// prefix classes and all of their person prefixes contain only low tones. In (10.16) me-vaḷã is of the //é-// class and the other three are of the //êè-// class. Cross-referencing elementary verb stems of the //e-// and //eé-// prefix classes do contain nonlow tones. Examples:

(10.17)	2s-V'st.c:	
	ɛ-bágá	'you move house'
	ɛ-gágã	'you get dry'
	ɛ-ván-ga	'you run'
	ɛé-gã	'you begin the morning'
	eé-pɛè	'you shout'

If the //é-// and //éè-// prefix class cross-referencing elementary verb stems are nominalized with a suffix the resulting noun stems take the prefixes usual for noun stems of their prefix class, which may have nonlow tone, e.g.:

(10.18)	éè-gaã-p	compare:	ee-gaã
	2s-go+sg.s-nz		2s-go+sg.s
	'your trip'		'you go'

This justifies considering the low tone cross-referencing prefixes as allomorphs of the //é-// and //éè-// prefix classes rather than as separate prefix classes.

A cross-referencing VP consists of an elementary or complex cross-referencing verb stem preceded by a cross-referencing person prefix, which always agrees in person and number with the subject of the S' which immediately dominates the VP. Section 6.4 above discusses the differences between cross-referencing and coreferential person prefixes. In the examples of cross-referencing VPs (underlined) below the dotted line indicates cross-reference with the clause subject.

(10.19)T	<u>pā-àt</u>	<u>pa-dá</u>	kára-ále-á
	1pi-let	1pi-stay	yet-fut-s.m

'Let's stay (and visit) awhile.'

(10.20)T "ajaa, ajaa... ĩip cípo mé-e-na
 (noises) tree point pPST+asr-th-lk

 a-bí-ñā kīi ĩi pí-á" kī-ip
 3c-foot?-set+pl.X (=go+out+pl.X) ints river from-s.m ev-rcI

'Ajaa, ajaa... a log was bobbing in the river.' (making noise)

(10.21)T soólók! eé téét alóp éèt
 enter (ideophone) then exct 3s pPST+pDEF+pSJV+asr

 aa-'-aá ĩi kac kī-ñap
 3c-penis enter (3s)-involve ev-ndef.tm

'Then he put his penis in him.'

The structure of the cross-referencing VPs in (10.20) and (10.21) are diagrammed below as (10.20a) and (10.21a). The symbol Ppfx.c indicates a cross-referencing prefix; person and number agreement is not otherwise formalized.

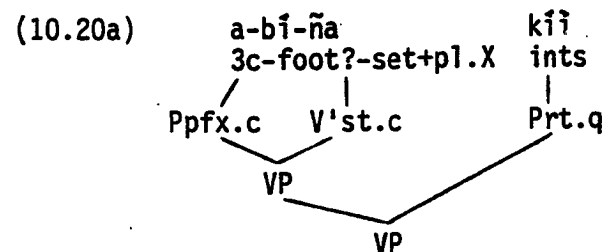

'go out a lot'

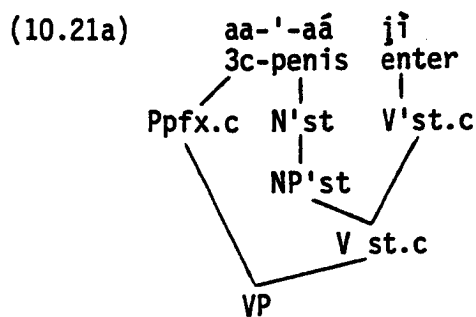

'put his penis in'

Phrase structure rule (10.22) generates cross-referencing VPs.

$$(10.22) \quad VP \rightarrow Ppfx.c - \left\{ \begin{array}{l} V'st.c \\ V \text{ st.c} \end{array} \right\}$$

10.4 Verb Phrases Composed of a Verb

Verb phrases which are composed of a verb contain only a single elementary or complex verb (disregarding any qualification particles).

Some examples with the maximal VP underlined:

(10.23)T jè goñát ná vé-téét teé pa-máge-é-na
 that spirit vz it-exct (=same) cont lpi-asr-th-lk

'We will continue with those same Goñát Spirit flutes.'

(10.24)T eé-na té pē-e jé-e-na
 th-Tk nasr thing-pl pPST+nDEF+uDUR+nasr-th-lk

darā kīi
 easily ints

'Like that things happened easily?' (In mythic times strange events were common.)

(10.25)T pi-gíp bó ci-ti ma-káá tá-bi'aá ma'á
 pick+up tz 3s-mother pPST+asr-go 3p-wrapped+up get

kī-á
 again-s.m

'His mother went to pick up the wrapped-up ones again.'

(10.26)T á-na kír-qt ibalà qòp
 whichever-lk impossible-1s-(nPST+pDEF+nasr) dance neg

kī, pa-gár-ábi ká qòp kī
 scope+marker lpi-sun-face (=day) in neg scope+marker

'I can't not dance, not have our day.' or: 'Whichever way, it's impossible for me not to dance, not to be in our day.' (This sentence contains a false ending after the comma. The speaker is expressing enthusiasm for a native festival on Brazil's Day of the Indian.)

Notice that sentence (10.26) demonstrates that a VP containing a verb or a postpositional transitive verb stem may be negated with the particle q̄op. The structure of VPs in (10.23) and (10.25) are diagrammed below as (10.23a) and (10.25a):

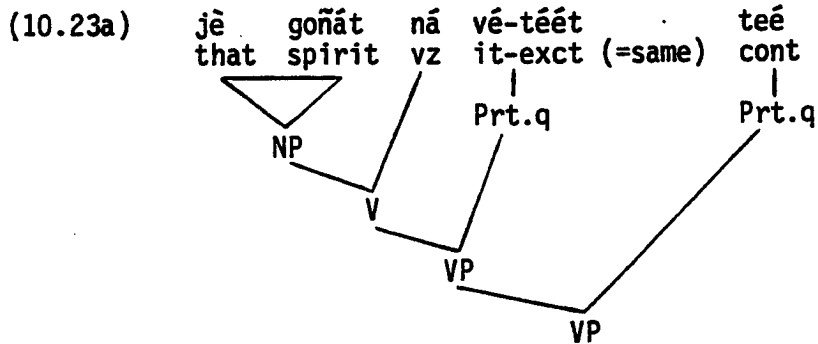

'continue with those same Goñat Spirit flutes'

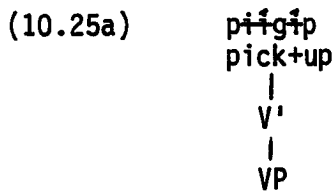

'pick up'

Phrase structure rule (10.27) generates VPs composed of a verb.

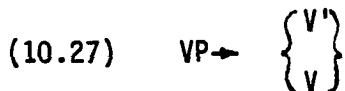

Some elementary verbs are very similar semantically to elementary cross-referencing or transitive verb stems. Examples with verbs and verb stems underlined:

(10.28)A

V': pájá ĩp mága 'The tree is breaking.'
 break tree asr

V'st.c:	aa-saà 3c-break	îip tree	mága asr	'The tree is breaking.'
V':	bîgã darken	e-mága 2s-asr		'You're getting dark.' (sun sets)
V'st.c:	e-gápavã 2s-darken	e-mága 2s-asr		'You're getting dark.' (sun sets)
V':	kîlîgã bite+dm	nekó cat	mága asr	ô-gac is-involve 'The cat bites me.'
V'st.t:	ô-va 1s-bite	nekó cat	mága asr	'The cat bites me.'
V':	ták--tágã beat-beat	e-mága 2s-asr	ô-gac is-involve	'You beat me a lot.'
V'st.t:	ô-dagã is-beat	e-mága 2s-asr		'You beat me.'

The examples in (10.28) imply that elementary verbs do not form a class which is semantically distinct from elementary verb stems. The elementary verbs can be roughly divided into three groups on a semantic basis.

The first group of elementary verbs indicate activity and have an implied object, which can appear as the direct object of the postpositional transitive verb stem kac 'involve'. The examples in (10.28) above illustrate this. Examples of V's indicating activity with implied object:

(10.29)	tîlîgã	'pinch'	baa-toò	'chew and spit out'
	zaana	'make war'	dólók--dólógã	'push repeatedly'
	dórá	'bump (into)'	cãlîã	'slip (on)'
	basanã	'steal'	pîgîp	'pick up'
	póã	'blow (on)'		

The second group of elementary verbs indicate activity without

an implied object, though a NP involved in some way in the action (e.g. accompanying it) may appear in the same S' as the object of kac 'involve'. Examples:

(10.30)	gakorãá	'hunt'	pórók--pórógá	'snore'
	ibalà	'dance'	gerè	'sleep elsewhere'
	pájá	'break'	ífná	'have a cold'
	berea	'sing'	bañá	'assemble'
	óójá	'rest'		

The third group of elementary verbs are semantically adverbial or qualitative:

(10.31)	bicaḡ-i	'at night'	bolí	'almost'
	ba'alà	'initially'	ḡfjá	'well, good'
	díá	'soon'	gólóá	'many'
	bḡrá	'full'	ḡlḡ	'afternoon'
	darà	'easily'		

There are no consistent morphological differences between the three groups of elementary verbs. There are no text examples of verbs of the third group with the negation particle óòp, though this is probably possible under the right circumstances. Verbs of the third group can occur with the intensification particle kíî, or be nominalized with the particles mát and méne, like any other verbs. They can occur as the only VP in a sentence. This is true of all verbs, except that piḡḡp 'pick up' must occur with ma'á 'get' somewhere in the same sentence. Formally, then, the third group appears to be just a semantic subclass of the elementary verb stems, not a separate category

of adverbs.

10.5 Summary of Verb Phrase Rules

The phrase structure rules presented in Section 10.0 are summarized in (10.32) below.

(10.32)

$$\text{VP} \rightarrow \left\{ \begin{array}{l} \text{VP} - \text{Prt.q} \\ \left\{ \begin{array}{l} \text{Ppfx} \\ \text{NP} \end{array} \right\} - \left\{ \begin{array}{l} \text{V'st.t} \\ \text{V st.t} \end{array} \right\} \\ \text{Ppfx.c} - \left\{ \begin{array}{l} \text{V'st.c} \\ \text{V st.c} \end{array} \right\} \\ \text{V}' \\ \text{V} \end{array} \right\}$$

11.0 CONJUNCTION

Conjunction is rare in Gavião speech; there are only nine text examples of conjunction, and some of these are sentence fragments. Informant responses to invented examples are inconsistent. In text examples only phrases, not sentences, are conjoined. Some examples of conjoined phrases are given below and some patterns are noted, but I cannot offer a secure formal analysis of conjunction.

11.1 Conjunction of VPs

Since a Gavião sentence can contain any number of VPs it is not clear why any conjunction of VPs occurs at all. The conjunction particle, kíí 'and, also', can occur after a single VP with the meaning 'also'. The syntactic marker -á immediately follows kíí:

(11.1)T tó-vít ñáp ná kíí-á áá
lpe-food place vz conj-s.m s.m

'Also to be a place for our food.' (sentence fragment)

Two (and probably more) VPs can occur conjoined with each VP followed by kíí and the right-hand boundary of the whole construction marked by the syntactic marker -á:

(11.2) (VP kíí,) VP kíí-á

Example with the conjoined VPs underlined:

(11.3)T eé-'-êéc bó mága ápékáat mága kíí,
that-pl tz asr big+pot make conj

qá mága teé kíí-á mákií-á
this make cont conj-s.m (3s)-make+pl.o-s.m

'Those (people) make big pots, make this (type), make lots.'

The syntactic marker -á can also occur after each conjoined VP and its conjunction particle:

(11.4) VP kíí-á, VP kíí-á

Sentence example:

(11.5)T aáv-á, goñát ná vé-téét pa-máge-é-na
 yes-s.m spirit vz it-exct (=same) lpi-asr-th-lk
 goñán-éèc tóló ká kíí-á, áp cīik ká kíí-á
 spirit-pl long+pl in conj-s.m flute small+pl in conj-s.m
 gá goñát dóól-éèc ná-á
 s.m spirit line-pl vz-s.m

'Yes, we're going to continue with those Goñát things, with long Goñát (flutes), with short flutes, with the Goñát file dance.'

Sentence (11.5) appears to contain a false ending (marked by áá) before the last VP. Informants feel that the syntactic marker -á following the first occurrence of the conjunction particle, kíí, in sentence (11.5) is optional. However, as a guess, the syntactic marker -á indicates the structural bracketing within the whole construction formed by conjunction, possibly indicating separateness of the events.

11.2 Conjunction of NPs

NPs conjoined with kíí occur in sentences (11.6) and (11.7) below. These two sentences appeared in succession in a text. The speaker seemed to lose track of what he was saying, and the two preposed VPs in (11.6) may be due to a false start.

(11.6)T "mát va téét bó jè kíííñáá kíí, jè vāsā-àc
 that eat exct tz that all ints that tapir-pl

kíí, jè nekó-èc kíí, jè poó pag-âc kíí-á
 conj that cat-pl conj that creature child-pl conj-s.m
 (=animals)

má-âc mé-e-na-á" kí-ip
 sb.nz-pl pPST+asr-th-lk-s.m ev-rc1

'All (of them) were eating that, the tapirs, the jaguars, all those animals were doing that.'

(11.7)T "jè bebê-èc kíí-á má-âc máâ-á" kí-ip
 that pig-pl conj-s.m sb.nz-pl pPST+asr-s.m ev-rc1

'Those peccaries also were there.'

In these examples each NP is immediately followed by the particle kíí and the right-hand boundary is marked by the syntactic marker, -á, which is immediately followed by a nominalization particle:

(11.8) (NP kíí,) NP kíí-á mát

A different pattern occurs in (11.9):

(11.9)T cíboój-aá kíí-á mát mooñ-aá kíí-á mát
 manioc-ft.o conj-s.m sb.nz cará-ft.o conj-s.m sb.nz

máge-é-na aa-vií eé-na mát ké-e-na
 asr-th-lk 3c-cook th-lk sb.nz in-th-lk

'Manioc and cará cook like that in that (pot).'

In (11.9) each NP is followed by kíí, then the syntactic marker -á, and then a nominalization particle:

(11.10) NP kíí-á mát NP kíí-á mát

This is possibly related to the fact that in (11.9) both manioc and cará are cooked, but they are not cooked together.

12.0 COMPLEX WORDS AND COMPLEX WORD STEMS

A complex word is a syntactic construction which (1) is composed of a person prefix or an elementary word followed by one or more elementary words or word stems and which (2) distributes like an elementary word within the phrase. A complex word stem is a syntactic construction which (1) is composed of an elementary word stem followed by one or more elementary words or elementary word stems (except for complex noun stems formed by the stem-deriving prefix, má-, followed by a complex noun) and which (2) distributes like an elementary word stem within the phrase.

It is the leftmost morpheme of a construction which determines whether it is a complex word as opposed to a complex word stem. Like elementary words, complex words can be minimal phrases. Like elementary word stems, complex word stems cannot be minimal phrases. They must be preceded by a person prefix or a nominal expression.

Complex words and word stems, unlike their elementary counterparts, consist of at least two phonological words or, rarely, one phonological word consisting of a person prefix and an elementary word stem (after person prefix attachment has occurred). Section 12.1 discusses phonological words and phonological junctures, providing the basis for distinguishing complex words and complex word stems from elementary words and elementary word stems.

Complex words and complex word stems are either derived or compound. Derivation is accomplished by derivational particles or, in the case of 'say/think' complex verbs, by the syntactic marker -á. The derivational particles differ from word stems in that they do not accept person prefixes and most of them either do not form

constructions with preceding nominal expressions at all or do so only with nominal expressions meeting rather abstract selectional restrictions. Derived complex words and word stems are discussed in Sections 12.2 and 12.3.

Compound complex words and compound complex word stems have as their right-hand immediate constituent an elementary word stem of major class membership, not a particle. Compound complex noun stems formed by the stem-deriving prefix, mā-, are an exception to this in that their right-hand immediate constituent is a complex noun. Compound complex words and word stems are discussed in Section 12.4.

Selectional restrictions are important in the composition of many complex words and word stems. Syntactic features are frequently used to express these restrictions in formal rules below. In most cases the constituent structure and category of a complex word or word stem are reasonably clear, but in a few cases there is some uncertainty.

12.1 Phonological Words

A phonological word is a unit composed of one or more morphemes which is bounded by external open junctures (## in systematic phonemic transcription, spaces in the orthography) but which contains no external open junctures. The constituent morphemes of a phonological word are joined to each other with internal closed junctures (+ in systematic phonemic transcription, a hyphen in the orthography) or, occasionally, by internal open junctures (# in systematic phonemic transcription, double hyphens in the orthography). A phonological word corresponds to the usual intuitive notion of a word as a unit which is a minimal free form: it is readily pronounceable in isolation and enters

freely into syntactic constructions with other such words (is not bound).

12.1.1 Juncture Type: Evidence from Segmental Sandhi and Boundness

Evidence for an internal closed juncture is supplied by the sandhi rules detailed in Appendix A. Evidence for internal open juncture is essentially by elimination of the other two alternatives: a juncture between two morphemes is assumed to be an internal open juncture only if there is positive evidence that it is neither an internal closed juncture nor an external open juncture. In practice the usual situation in which an internal open juncture is recognized is one in which an interface between two morphemes does not exhibit the phonological changes characteristic of internal closed juncture, but one or both of the morphemes involved is clearly bound (is not a free form). Some examples with the internal open junctures underlined and the base forms given to the right:

(12.1) <u>dố-</u> '-aã 'urucu fruit'	/// <u>##doo#aã##</u> /// urucu-fruit
e-mã-'-áv+!+ 'your dog'	/// <u>##e+mã#áv+!+##</u> /// 2s-poss-dog
e-vé-'-ígi 'get yourself out'	/// <u>##e+vé#ík+í##</u> /// 2s-intr-remove-stem+formative
dạc--ka 'dent something'	/// <u>##∅+dạy#ka##</u> /// (3s)-dented-cause
tợk--tợg-ã 'beat repeatedly'	/// <u>##tợk#tợk+ã##</u> /// beat-beat-stem+formative

In the first three examples in (12.1) the internal open juncture occurs between vowels, manifesting itself as a glottal stop. The vowels do not merge into one syllable as they would if separated by

internal closed juncture:

- (12.2) *dô-a 'urucu fruit'
 *e-mâ-âv+lî 'your dog'
 *e-vê-îgî 'get yourself out'

Each of the first three examples in (12.1) contains one or more bound morphemes. The bound noun root, dô- ~ doo- 'urucu', also occurs in doo-kâap 'urucu seed', but not in isolation. The second and third examples in (12.1) involve derivational affixes, mâ- and vê-, which are clearly not minimal free forms.

In the fourth and fifth examples in (12.1) the internal open juncture blocks the nasal sonorantization and consonant voicing which would occur across internal closed junctures even in slow speech:

- (12.3) *dañ-ga 'dent something'
 *tôg-dôg-â 'beat repeatedly'

The morphemes dac-, -ka, and tôk- in (12.1) are bound. For example, dac- cannot occur without a suffix:

- (12.4) *dac mää 'It's dented.'
 (3s)-dented (3s)-pCOP+asr

12.1.2 Juncture Type: Evidence from Length Sandhi

Evidence for juncture type in words and stems is sometimes provided by lengthening and shortening rules which operate only within, not across, external open junctures. In general a long syllable becomes short (or a short syllable does not lengthen) when followed by a nonaffixal short syllable within a phonological word:

- (12.5) pō-kâc--âp ///##pavô+kây+V̂V#âp##//
 'firestick' thing-burning-stem+formative-stick
- cf: pō-kâc 'fire'
- qô-ja-kâp-kít ///##qô+ya+kâp+kít##//
 'white of my eye' 1s-eye-s.r.o-white
- cf: qô-ja-kâp 'my eye'

In the first example in (12.5) the long syllable produced by the adjective stem formative process (symbolized by V̂V) was then shortened to -kâc- due to a following short syllable, indicating the juncture immediately preceding âp is not an external open juncture. If that juncture were an internal closed juncture, then *pô-kâñ-âp would result by regular sandhi rules. Therefore the juncture is an internal open juncture. In the second example in (12.5) the internal juncture between p and k could be either open or closed since voiceless consonant clusters following oral vowels are not affected by any phonological rules. Such cases are arbitrarily considered to have internal closed juncture.

In elementary nouns which are not usually possessed (and in their corresponding noun stems) nonfinal syllables are often (though not always) lengthened if the final syllable is long or is lengthened. This provides evidence that a construction is one phonological word, not two. Examples:

- (12.6) bee-kâa ///##be+kâa##//
 'clearing on path' w+path-clearing(?)
- zôoc-kâap ///##zoy+kâp##//
 'Rain Star' w+rain-s.r.o
 (prominent in the rainy season)

In (12.6) the internal juncture is arbitrarily assumed to be

closed; the morpheme interfaces in the two examples are not such as to be affected by the segmental sandhi rules.

The juncture between two constructions, each of which can be minimal free forms, is assumed to be external open juncture unless this is ruled out by (1) positive sandhi evidence for internal closed juncture or (2) by lengthening or shortening changes of the type illustrated in (12.5) and (12.6).

12.2 Complex Words Derived from Phrases, Clauses, or Quotes

Three particles and the 'say/think' quotation process derive complex words from other syntactic constructions in a fully productive fashion. These derived complex words are very common.

12.2.1 Complex Nouns Derived with mát and méne

Many examples of the nominalization particles mát (substantive) and méne (nonsubstantive) are given in Section 6.3.11. These two particles derive complex nouns from VPs and from S's of the nominal sentence functional type. Some examples with the complex noun underlined:

(12.7)T gốc mi mát 'automobile'
ground use sb.nz

(12.8)A zoc mi méne 'rainy season'
w+rain use nsb.nz

(12.9)T eé-na mát pí bó té tó-ka
th-1k sb.nz from tz nasr lpe-(pPST+pDEF+nasr)-go

eé pí teé jê tá-s+g+ má-ác kac
that from cont that 3p-near sb.nz-pl involve

'From there we went to those near them.' (Cinta Larga dialect)

(12.10)T ǫ̀o té me-sá ǫ̀á sérék tá méne íkini
 neg nasr 2s-nasr this (3s)-clothing with nsb.nz see

'Don't you see how she is with her clothing?' (pregnant)

(12.11)T "eé bó pazé-èc máà sóp abí palí
 then tz other-pl pPST+asr claypit beside pachiuba

sábèè ánéè a-vé-pea māt picaā
 board (pPST+pDEF)-nom 3c-intr-beat+pl.o sb.nz standing+pl

māga-ā" kī-ip
 put-s.m ev-rcl

'Then others put upright beaten pachiuba boards beside the claypit.'

In (12.9-12.11) the nominalizations are the objects of transitive verb stems. Examples (12.9) and (12.11) provide evidence that they are complex nouns rather than NPs or NP's: they can be modified by demonstratives and by adjective stems, thus distributing inside the NP like an elementary noun:

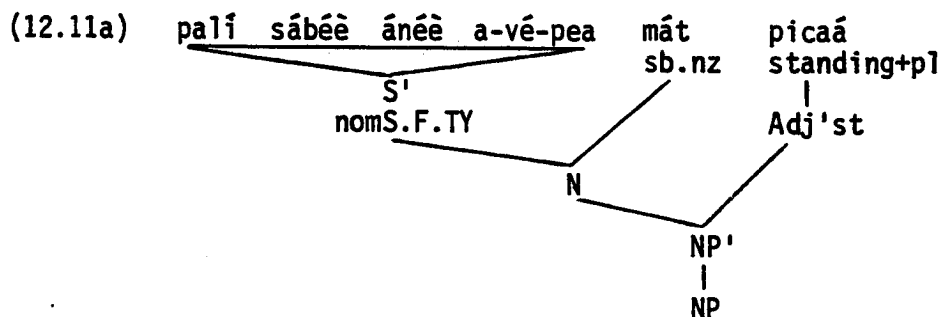
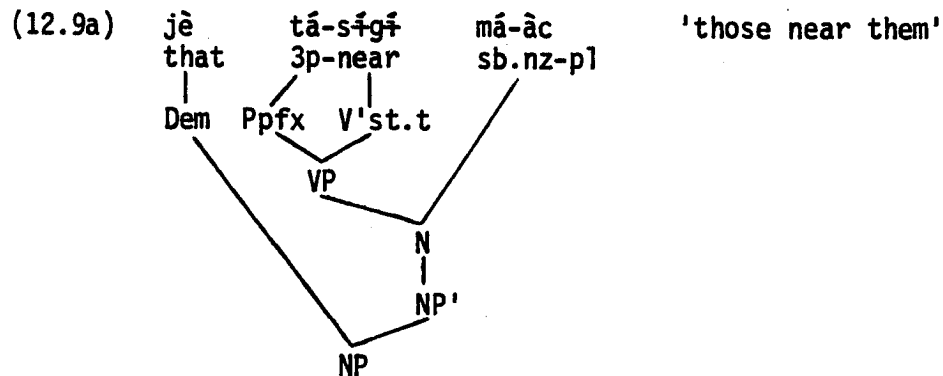

'upright beaten pachiuba boards'

Rule (12.12) generates complex nouns derived with the nominalization particles:

$$(12.12) \quad N \rightarrow \left\{ \begin{array}{c} S' \\ \text{nomS.F.TY} \\ VP \end{array} \right\} - \left\{ \begin{array}{c} \underline{\text{mât}} \\ \underline{\text{méne}} \end{array} \right\}$$

12.2.2 Complex Verbs Derived with ná

The verbalization particle, ná 'as, in the capacity of', derives complex verbs from NPs. Examples with complex verbs underlined:

(12.13)T eé pát áp máà kol-áp ná
that thing l.t.o pPST+asr flute-l.t.o vZ

tǎá-jere ná kǐ-á
3p-thing+in+front+of vZ again-s.m

'That thing (bamboo) was playing like a flute in front of them.'

(12.14)T tó-vít viǐ-p ná
lpe-food cook-nz vZ

'To be something (with which) to cook our food.' (sentence fragment, answer to 'Why do you make pots?')

(12.15)T jè goñát ná vé-téét teé pa-máge-é-na
that spirit vZ it-exct (=same) cont lpi-asr-th-lk

'We are going to continue playing those same Goñát flutes.'

Because of the relative simplicity of VP structure it is not possible to prove that ná constructions are complex verbs as opposed to VPs. I shall assume that they are complex verbs, paralleling the complex nouns formed by the nominalization particles, mât and méne.

Structure diagrams:

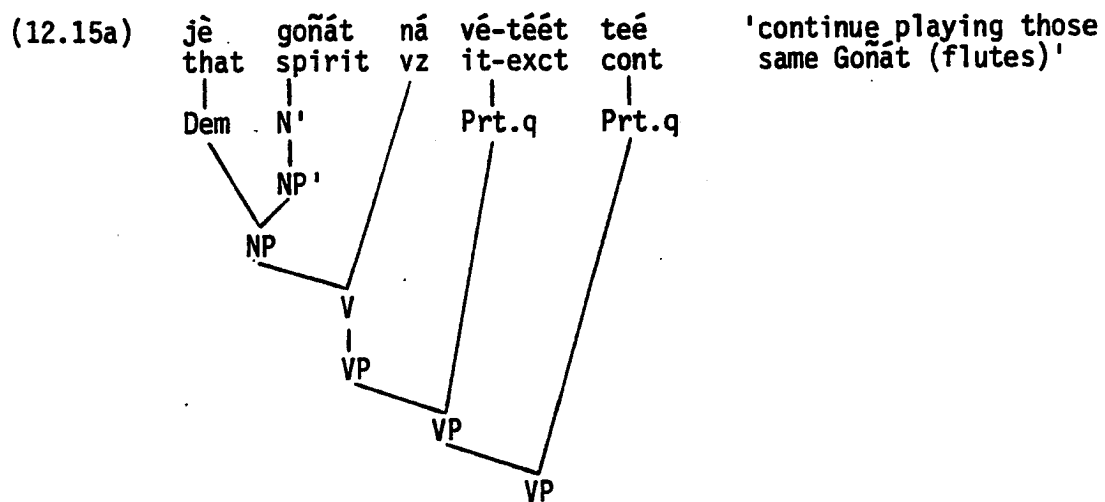
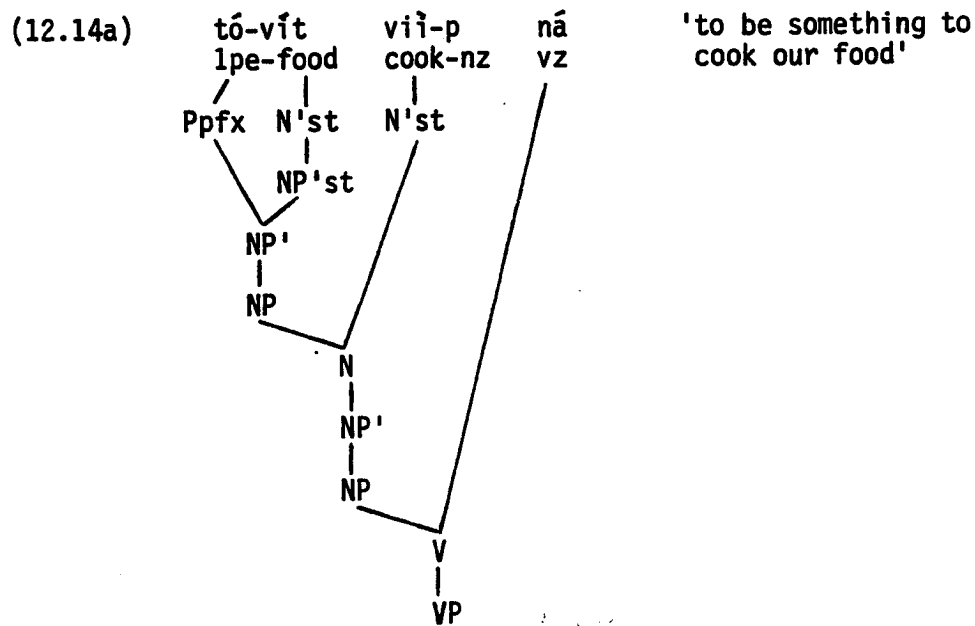

Phrase structure rule (12.16) generates complex verbs derived with ná:

(12.16) $V \rightarrow NP - \underline{ná}$

12.2.3 Complex Say/Think Verbs Derived with -á

A 'say/think' construction is derived from an utterance or thought by adding the syntactic marker, -á, to its right-hand boundary. These

'How do you find pottery clay in the forest?' ('Thinking, "Is it pottery clay?" how do you find the clay in the forest?')

Example with a thought inside quoted speech:

(12.20)T "'eé bô té zâ madék tîî aka-â" ôõp
 there tz nasr 1s+nasr lizard big kill-s.m neg
thought
 speech

bô é-ga-â' mää kaj-â" kí-ip
 tz 2s-(pDEF+imp)-go-s.m (3s)-pPST+asr (3s)-involve-s.m ev-rcl
speech

'"Go ahead without thinking about killing the Giant Lizard," he said to him.' (Though not underlined, everything preceding the particle kí-ip 'recalled evidence' is formally quoted speech, recalled from a traditional story.)

There appears to be no contrast between direct and indirect attributed speech/thoughts in Gavião. The speech/thought appears exactly as said or thought. In particular, third person prefixes within the attributed material do not indicate coreferentiality with the sentence subject as they do in subordinate clauses marked with -â. For example, in the sentence below the first person singular possessor of 'nature' is coreferential with the third person subject of the sentence, but the third person coreferential prefix does not occur on 'nature':

(12.21)T "é-géré bēre mi-â" éêt
 2s-exh+go 1s+nature use-s.m (3s)-pPST+pDEF+pSJV+asr
speech

kí-nap
 ev-ndef.tm

'"Go do like me!" he said.'

There appears to be one exception to the generality that the

attributed material appears exactly as spoken or thought: at least some demonstratives in say/think complex verbs can be interpreted as indirect speech/thoughts:

(12.22)T eé-'-éêc jé-e-na ci-té-e-na kíi
 that-pl pPST+nDEF+uDUR+pSJV+asr-th-lk 3s-with-th-lk ints
 "aá-na-á" teé kíi kí-nap
 this-lk-s.m cont ints ev-ndef.tm
 speech

'They were with him, talking like that.'

In (12.22) the people were not actually saying 'aá-na', which is, rather, an anaphoric reference to what the people had said in the text sentences immediately prior to (12.22).

A say/think construction is considered to be a complex verb because it distributes within the phrase like an elementary verb such as, say, ibalâ 'dance'. The VP immediately dominating the say/think complex verb can be preposed like any other. It can be modified by qualification particles such as ôôp 'negation' in (12.20) above or kíi 'intensification' in (12.22) above and can also be nominalized by the particles mát or méne:

(12.23)A até-á mát 'someone who says "yes" a lot'
 yes-s.m sb.nz

The utterance or thought to which the syntactic marker -á is attached will be designated formally as an Utterance/Thought. This is a reasonably accurate and suggestive designation, but it should be understood broadly so as to include noises which are not speech. The phrase structure representation of the VP containing the attributed thought in (12.20) is given below as (12.20a):

12.20

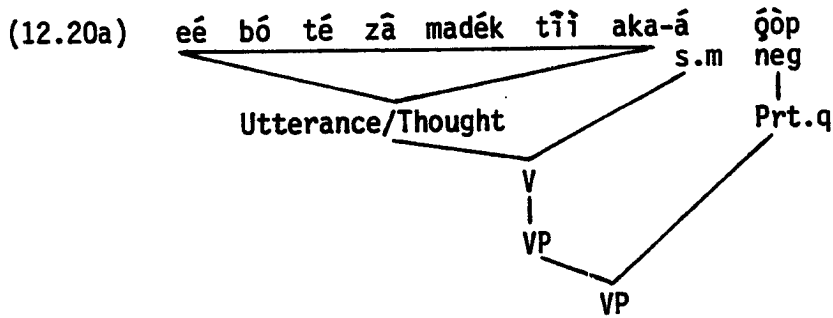

'not (thinking), "there I'll kill the Giant Lizard"'

Phrase structure rule (12.24) generates say/think complex verbs:

(12.24) $V \rightarrow$ Utterance/Thought - -ā

12.3 Complex Words and Complex Word Stems Derived from Elementary Words and Word Stems or from Complex Words

There are four (possibly five) Gavião particles which derive complex words and complex word stems in a fully productive fashion from elementary words and elementary word stems. One of these, tígí 'causative', can also form constructions with nonsubstantive elementary or complex nouns. These derivational particles are each examined below.

12.3.1 Complex Adjective Stems Derived with déè

The particle deè 'past participle' derives complex adjective stems from preceding elementary verb stems. The resulting complex adjective stem translates as the past participle of the verb stem. Example with the complex adjective stem (underlined) modifying a preceding noun stem:

(12.25)T eé-na té pa-zópop ajálá déè já,
 th-1k nasr lpi-remainder leave pst.prt pPST+nDEF+uDUR+
 nasr díinibíi ájere ná, ici-a ágó-a koc
 name thing+in+front+of vz rock-ft.o heart-ft.o at

'Thus were the left-behind rest of us, in front of Dīnībī, inside the rock.'

In the above example the verb stem is transitive: ajālā 'leave'. Informants agree that dēè can also follow cross-referencing verb stems:

(12.26)A paderè āgāà dēè 'person who has begun
 person begin+morning pst.prt the morning'

Since *paderè āgāà is not a grammatical construction, the constituent structure of (12.26) must be as in (12.26a):

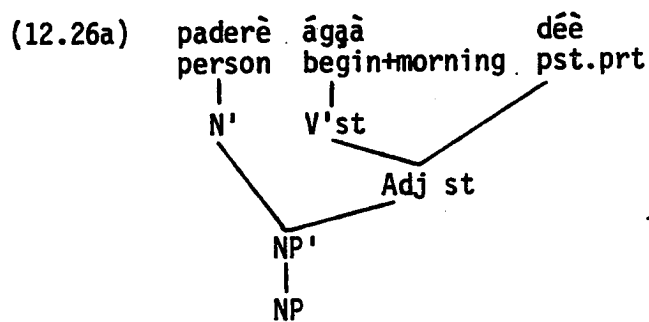

No qualification particles (e.g. qôp 'negation') can intervene between the V'st and dēè. Complex verb stems cannot form constructions with dēè. Clearly the left-hand immediate constituent of dēè constructions is the preceding elementary verb stem. Complex stems formed with dēè are considered to be adjective stems because (1) they distribute like elementary adjective stems within NPs, and (2) their third person singular prefixes, like those of elementary adjective stems, translate as an indefinite 'something' rather than as the third person possessors of noun stems, 'his, her, its'. Phrase structure rule (12.27) generates complex adjective stems derived with dēè:

(12.27) Adj st → V'st - dēè

12.3.2 Complex Verbs and Complex Verb Stems Derived with ma-téé

The particle ma-téé 'causative' derives complex verbs from preceding elementary verbs and derives complex verb stems from preceding elementary verb stems. This particle is phonetically identical to the transitive verb stem ma-téé 'send, spend' (< //ma-// 'transitivization' + //tɛ+ɛ̃// 'go, flow'), but informants claim there is no idea of 'send' in the causative constructions. Example with a double occurrence of ma-téé (complex verb stem and complex verb underlined):

(12.28)T "méne tóòt téét bó alóp máà a-maa-káap
 that attached extc tz 3s pPST+asr 3c-peanut-s.r.o
ígí ma-téé bañà ma-téé alé-ec kaj-á" kí-ip
 take+out cause assemble cause 3s-pl involve-s.m ev-rc1

'That was the truth; he had them get together and harvest his peanuts.'
 (Either there is an error in the first three words or else the sentence is aberrant, having something in the sentence-initial DemP which is not a DemP.)

Notice that the causees, alé-ec 'them', are the object of the transitive verb stem kac 'involve'. The particle ma-téé is always preceded by an elementary verb or verb stem; nothing can intervene, supporting the claim that it forms constructions with these as the left-hand immediate constituent. In text examples ma-téé follows verbs and transitive verb stems, as in (12.28). Informants claim elementary cross-referencing verb stems can also precede ma-téé:

(12.29)A o-gerè ma-téé e-mága 'You are making me sleep.'
 is-sleep cause 2s-asr

In these cases the Gavião prefer to use the transitivizing prefix, //ma-//:

(12.30)A ó-ma-kéré e-mága 'You are making me sleep.'
 1s-tr-sleep 2s-asr

Complex verb stems derived with ma-téé would appear to always be transitive. The derived complex verbs of course take no objects and cannot be prefixed for person. The constituent structure of the VPs containing the complex verb stem and complex verb in (12.28) above are given as (12.28a):

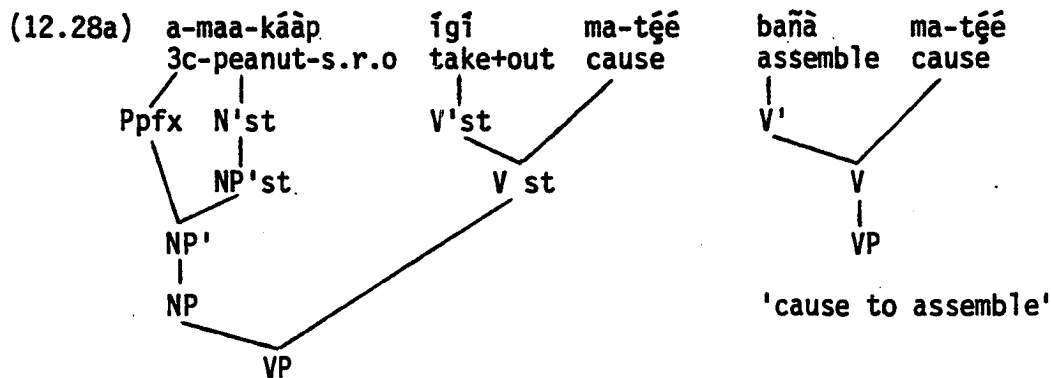

'cause to harvest his peanuts'

Phrase structure rule (12.31) generates complex verbs derived with ma-téé, and rule (12.32) generates complex transitive verb stems derived with ma-téé:

(12.31) $V \rightarrow V' - \underline{ma-téé}$

(12.32) $V \text{ st.t} \rightarrow V'st - \underline{ma-téé}$

12.3.3 Complex Verbs and Complex Verb Stems Derived with tígí

The particle tígí 'causative, cause to become' forms complex transitive verb stems with an immediately preceding elementary adjective stem. These complex verb stems translate as 'cause to become adjective stem'. Example with the complex verb stem underlined:

(12.33)T saa-bi pḕep tígí
 3s-face black cause

'to blacken its surface' (sentence fragment about firing pots)

The constituent structure of (12.33) is presumably as given in (12.33a):

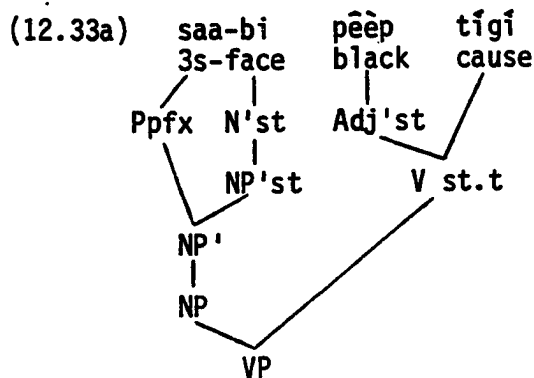

'blacken its surface'

Phrase structure rule (12.34) generates complex transitive verb stems derived from elementary adjective stems by tígí:

(12.34) V st.t ← Adj'st - tígí

The particle tígí also forms causative constructions with immediately preceding nonsubstantive nominalizations. There are two types of nonsubstantive nominalizations, one morphologically derived and one syntactically derived. The suffix // -ve// derives nonsubstantive elementary nouns from elementary verbs and derives nonsubstantive elementary noun stems from elementary verb or elementary adjective stems. These derived elementary noun stems are pARG, taking the preceding NP or person prefix as their argument. Example of a causative construction (underlined) containing a morphologically

derived nominal:

(12.35)T māt bó èèt a-mápê-e tígí
 that (=he) tz pPST+pDEF+pSJV+asr 3c-shoot-nsb.nz cause

a-sávât--tẹ-é-na kí-nap
 3c-jumping-become-th-1k ev-ndef.tm

'He jumped up, getting himself shot.'

The constituent structure of the VP containing the causative construction in (12.35) is possibly as given in (12.35a) or possibly as given in (12.35b):

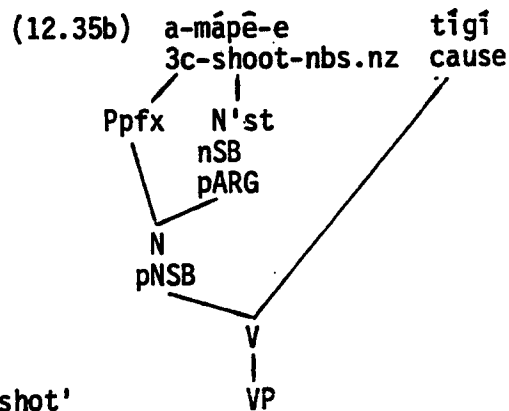
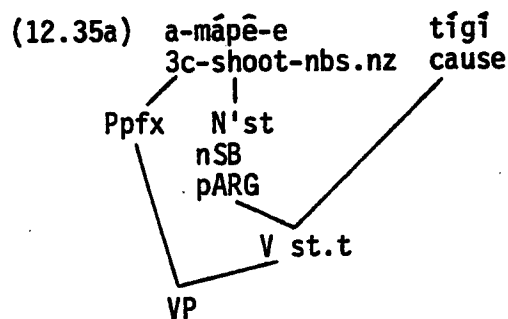

'get himself shot'

Either (12.35a) or (12.35b) seem possible on semantic grounds, and (12.35a) parallels the structure of (12.33a). However, I shall assume that (12.35b) is the correct analysis because that parallels the structure of causative constructions formed with nonsubstantive nominalizations syntactically derived by the particle méne. Examples of those, with the causative complex verb underlined:

(12.36)T jè a-ma-'-iì òò-c népo ká méne
 that 3c-poss-chicha eat-actors arm in (=on) nsb.nz

tígí kíi-á
 cause ints-s.m

from nonsubstantive nouns by the particle tígi:

$$(12.38) \quad V \rightarrow \left\{ \begin{array}{c} N' \\ N \\ nSB \\ nFIN \end{array} \right\} - \underline{tígi}$$

The negative value for the feature SB 'substantive' occurs on complex nouns derived with méne and on complex nouns whose head is an elementary noun stem derived with // -ve//. It also occurs on elementary nouns derived with // -ve//, e.g. ibalê-e 'dance, dancing'. When tígi occurs after a substantive noun it is interpreted as the phonetically identical transitive verb stem, tígi 'knock down, singular object'. Rule (12.38) stipulates a negative value for a feature FIN 'finite' as a formal means of excluding S's nominalized with méne, which cannot occur in causative constructions.

12.3.4 Time and Place Constructions Derived with tígi

The particle tígi 'time', 'place' occasionally has a high second tone. The conditioning factor is uncertain, but the tígi form appears to always precede a phonological word with initial high tone occurring in the same phrase (e.g. jè tígi pí 'that place from', 'from there').

The particle tígi forms constructions with preceding elementary noun stems which designate some sort of event. This restriction is expressed formally by assigning these noun stems a plus value for a feature EVENT. The resulting construction is a complex transitive verb stem which translates roughly as 'at the time that N'st of object occurs'. Examples with the complex verb stem underlined:

(12.39)T "mā-'-iī kakɪc tīgi é-á kótkòòr-á'
 1s+poss-chicha desire time tag+Q-s.m uncle-s.m

māà kaj-á" kí-ip
 (3s)-pPST+asr (3s)-involve-s.m ev-rcl

'"When I want my chicha, right, Uncle?" he said to him.'
 (The subject acknowledges being distracted by thoughts of food.)

(12.40)T bêre tīgi 'when I feel like it'
 1s+nature (=disposition) time

Elementary noun stems and nouns formed with the nominalization suffix // -p// are pEVENT and can form constructions with tīgi. There are no text examples of this, but informants freely create and accept examples. Example with a derived elementary noun stem:

(12.41)A iī va-p tīgi 'at the time of drinking chicha'
 chicha drink-nz time

Elementary adjective stems also form complex transitive verb stems with tīgi:

(12.42)A e-vóòp tīgi 'when you are red'
 2s-red time

Demonstratives which do not indicate proximity (má 'some, other' and náapó 'past') form temporal complex verbs with tīgi:

(12.43)T móòc akiɪt tá-māà má tīgi-á
 one kill+dm 3p-pPST+asr other time-s.m

'They killed one another time.'

Two temporal elementary verbs contain tīgi:

(12.44) á-nám-dīgi 'when'
 which-number-time

árá-tígi
ancient-time

'in ancient times'

Clearly tígi does not have phrase scope since no qualification particles can immediately precede it. It could be argued in cases such as (12.41) above that the scope of the particle is the preceding complex noun, not the preceding elementary noun stem. This cannot be ruled out, but in cases such as (12.42) it seems more likely that the scope of tígi is the preceding elementary (adjective) stem, not the whole NP', e-vóòp. So I shall make the simplest assumption, that the scope of tígi is the preceding elementary word or elementary word stem. Then the phrase structure of (12.41) is:

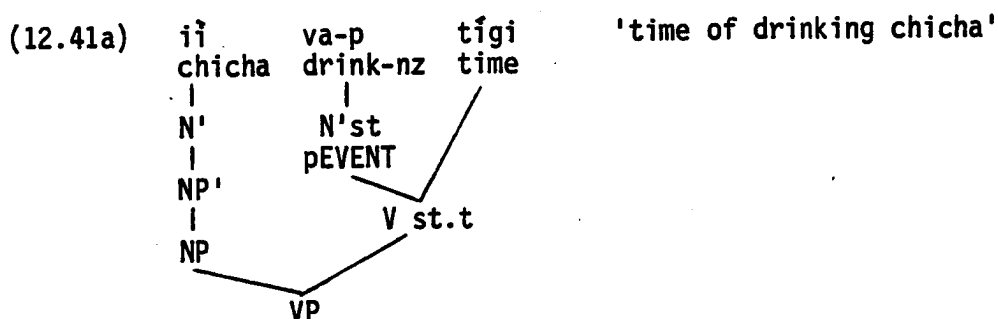

Temporal complex transitive verb stems derived by tígi are generated by rule (12.45) below. The temporal complex verbs are generated by rule (12.46).

$$(12.45) \quad V \text{ st.t} \rightarrow \left\{ \begin{array}{l} N'st \\ pEVENT \\ Adj'st \end{array} \right\} - \frac{tígi}{'time'}$$

$$(12.46) \quad V \rightarrow \left\{ \begin{array}{l} N' \\ pEVENT \\ Dem \\ nPROX \end{array} \right\} - \frac{tígi}{'time'}$$

When a demonstrative which indicates proximity precedes tígi the resulting construction indicates a specific location, not time:

(12.47)T gā tígi pí èt àle-ċ
 this place from 2s-(pDEF+imp) future-s.m

'Do it from there.'

(12.48)T "jè tígi mát vā kā teé é-ga
 that place sb.nz hole in cont 2s-(pDEF+imp)-go

àle-á' tá-māā kaj-á" kī-ip
 fut-s.m 3p-pST+asr (3s)-involve-s.m ev-rcl

"Go into that hole," they said to him.'

The tígi construction in (12.48) is certainly a complex verb since it is nominalized by mát. Certainly the tígi construction in (12.47) is not verbal since it is the object of the postpositional transitive verb stem pí '(be) from'. It would appear to be either a complex demonstrative or a complex noun, and in general there is little motivation for a category of complex demonstratives. 'Measurement' expressions (e.g. môôc 'one') distribute like both verbs and nouns. The 'place' complex words formed with tígi appear to parallel the measurement expressions, and I shall assume that these constructions can be either complex verbs or complex nouns:

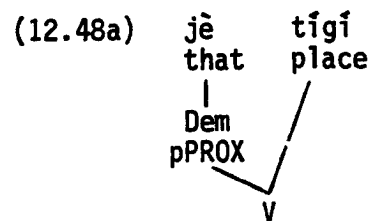
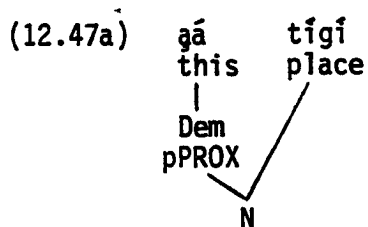

Phrase structure rules:

(12.49) N→ Dem - tígi
pPROX 'place'

(12.50) V→ Dem - tígi
pPROX 'place'

12.3.5 The Problematical Particle pát

The particle pát occurs after demonstratives which indicate proximity. It is not certain that this is a derivational particle as opposed to a qualification particle, possibly related to the contrastive qualification particle, pátpát. Examples:

(12.51)T ja-'-ǫp aka té pa-á
(3s)-eye-nonexistent+pl (=unaware) kill nasr lpi-nasr

baalà eé pát aka kǐ
initially that ? kill again

'We kill that type when they are still unaware?'

(12.52)T eé pá-na té mā-i-jaàc já-á
that ?-lk nasr ?-chicha-owner pPST+nDEF+uDUR+nasr-s.m

'Like that the host spoke?'

(12.53)T eé pát áp mää kol-áp ná,
that ? l.t.o pPST+asr flute-l.t.o vz

tǎá-jere nā kǐ-á
3p-thing+in+front+of vz again-s.m

'That thing (bamboo) was playing like a flute in front of them.'

The meaning of pát seems to be contrastive or possibly 'type'. The constructions it forms with demonstratives may well be demonstratives since only demonstratives are known to occur before the manner suffix, -na, as in (12.52). However, there are no examples at hand of these constructions occurring sentence initially as DemPs, nor of

their modifying NP's as demonstratives do. There is an elementary noun stem, pāt, meaning 'possession, thing':

(12.54) ɛ-bāt 'your thing' ɛ-bāt cīit 'your flower'

The analysis of pāt will be deferred and not included in the grammatical rules.

12.4 Compound Complex Words and Word Stems

Compound complex words and word stems are in general less productive constructions than the derived complex words and word stems. The formation of compound complex nouns and noun stems and of compound complex cross-referencing verb stems is quite productive, but compound complex adjective stems are very marginal.

12.4.1 Compound Complex Nouns and Noun Stems

The very common compound complex nouns and noun stems are in principle indefinitely long, unlike compound elementary nouns and noun stems. As explained in Section 3.2 above, each elementary word stem belongs to one of four person prefix classes and each elementary noun stem also has certain values for the four nominal construction type subcategorization features, which determine the possible relations it may have with a preceding nominal expression: INAL 'inalienably possessed', ALN 'alienably possessed', MOD 'modified', and ARG 'takes preceding nominal as its argument'. The first two of these are discussed in Section 9.3.2 above.

Each compound complex noun stem has (1) the person prefix class and (2) the nominal construction type feature values of its leftmost

constituent elementary noun stem:

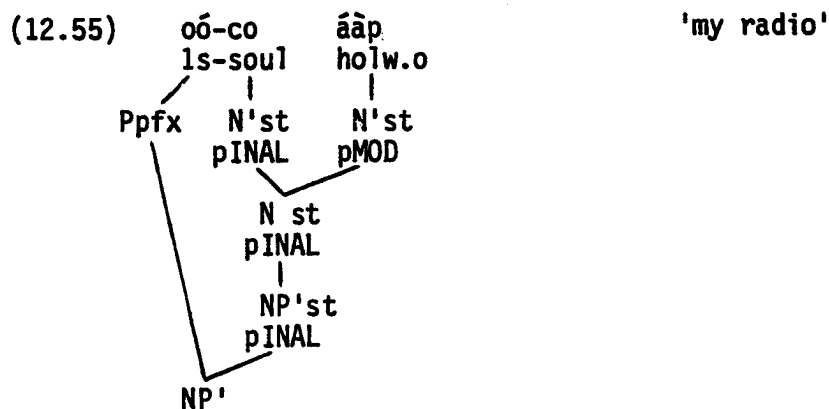

In (12.55) the compound complex noun stem íco áâp 'radio' (the initial vowel deletes during person prefixation) is of the //eé// person prefix class and is inalienably possessed since these are the properties of the leftmost noun stem, íco 'soul, likeness'. The compound complex noun stem 'radio' must be possessed, though one can speak of radios in general by using the first person plural inclusive prefix: paá-co áâp '(our) radio(s)'.
 A compound complex noun accepts the pALN stem formative prefix, má-, if it begins with an elementary noun which accepts it:

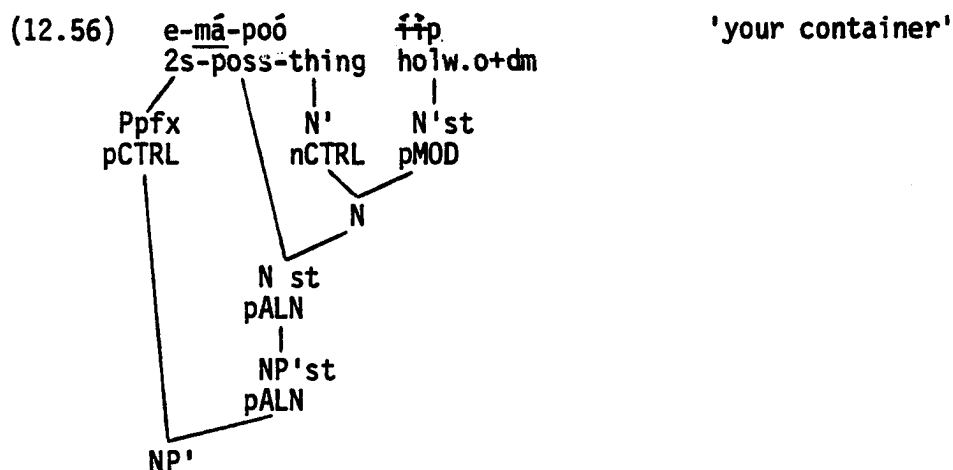

quite productive.

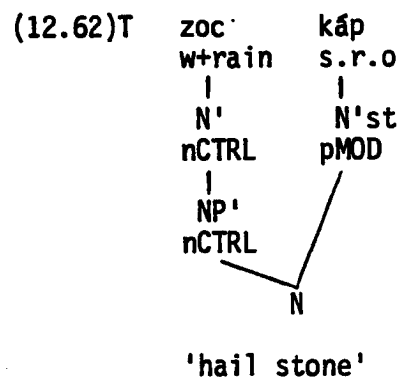
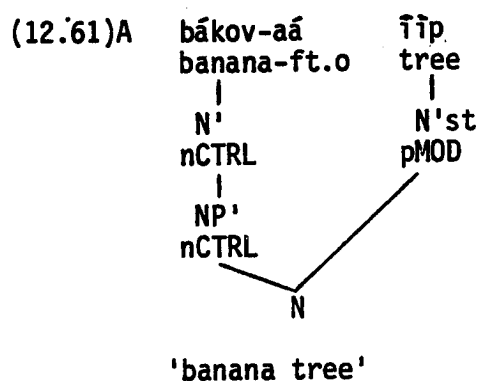

There are three types of pMOD elementary noun stems. All are nINAL and nARG. The first type, exemplified by îip 'tree' and by the other stems listed in (9.22), Section 9.3.2 above, have a phonetically identical corresponding elementary noun (e.g. îip 'tree'). These stems are nALN, but a pALN stem can be formed with the prefix má- (e.g. má-'-îip 'tree').

The second type, exemplified by a 'house, village' and by the other stems in (9.23) above, is pALN as well as pMOD. The corresponding noun is either phonetically identical, e.g. a 'house, village', or formed with the 'w' word-deriving prefix.

There is also a third type of pMOD elementary noun stem, exemplified by káp 'small, round object'. Most of these are shapes or forms. Some have corresponding pINAL stems, which, however, have a narrower, more concrete meaning. For example, káp means 'egg' as a pINAL elementary noun stem and can only be possessed by something which lays eggs. This third type of pMOD noun stem is always nALN and can only be alienably possessed indirectly using the dummy noun stem, pát 'thing, possession', e.g. ę-bát káp 'your small, round

object (perhaps a bird's egg). As elementary nouns, words like káp are often used for anaphoric reference to objects of the particular shape or form which they denote.

All of the reasonably clear examples of this third type of pMOD noun stem are listed below. Doubtful cases are indicated with a question mark, and any corresponding pINAL noun stems are listed with their glosses.

(12.63)	N'st and N' pMOD	2s-N'st pINAL	Gloss
fruit-like object	aá	éê-'-aá	penis
long, thin object	áp		
hollow/convex object	ââp	e-'-ââp	vagina
liquid	ci	é-ji (?)	sweat
insides	cíbák (?)		
flower	cîit		
small, round object	káp	ę-gáp	egg
beach	kââp		
long, thin object	kâli	ę-gâli	bone
cob	kĵit (?)		
string	kítap		
powder	kôôp		
root	págaá		
piece	pékââp		
bark-like object	sábéè		
root	ságaá		
leaf-like object	sep		

Gloss	N'st and N' pMOD	2s-N'st pINAL	Gloss
hair-like object	sép		
paste	tága		
string-like object	tápôò	ɛ-dápôò	throat, vein

The maximal construction which modifies a pMOD head is a NP' or NP'st since the modifying construction does not contain demonstratives or qualification particles but may contain elementary or complex adjective stems:

(12.64)T eé-na gôóc koñò déè va ká teé
 th-lk ground dig pst.prt hole in cont

tá-máge-é-na máki-í-na pôòc máki-í-na
 3p-asr-th-lk (3s)-make+pl.o-th-lk (3s)-big make+pl.o-th-lk

'Like that, in a hole dug in the ground they make (them), make big (ones).'

(12.65)T "sép kâác kôòp avák tígí alé-ec
 hair burnt powder scattered cause 3s-pl

kaj-â" kí-ip
 involve-s.m ev-rc1

'(Did it) to them (by) scattering the powder of the burnt hair.'
 (sentence fragment explaining how the Nonhunter cursed the hunters by burning the hair of their game and scattering the ashes)

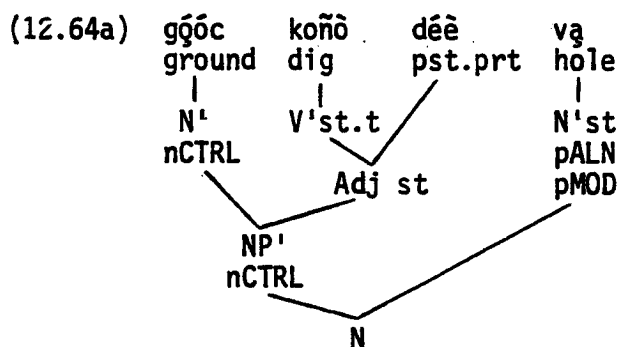

'hole dug in the ground'

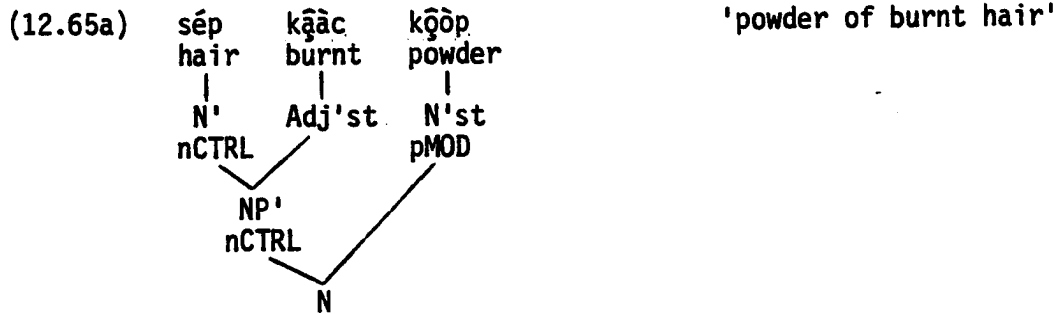

The NP' modifying a pMOD noun stem can consist of a possessed NP' stem, providing that the NP' is noncontrolling:

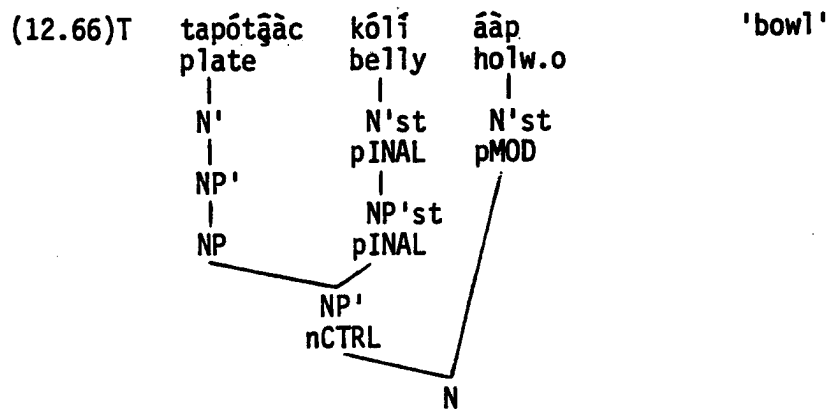

Example of a possessed compound complex noun stem:

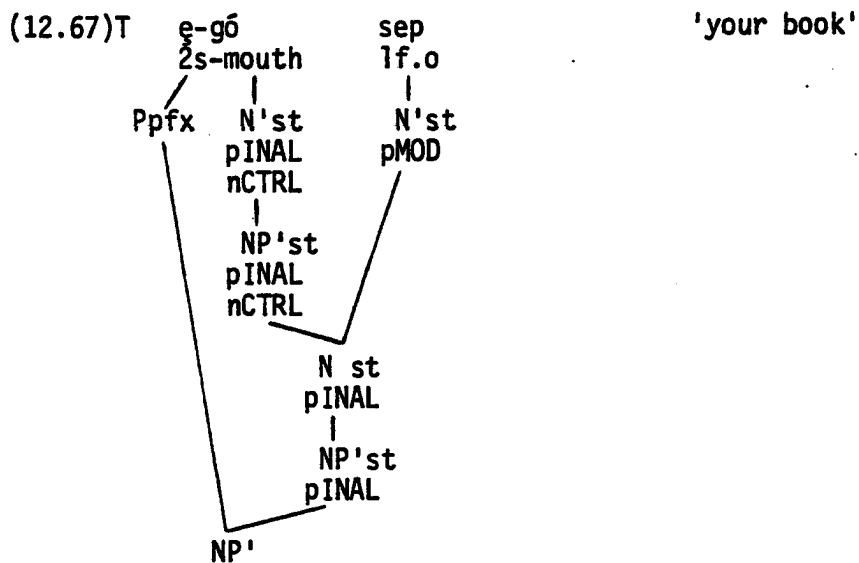

It would seem that the pMOD head of a compound complex noun or noun stem could itself be a compound complex noun stem, but there are no clear examples of this. So, assuming that the head is always an elementary noun stem, the phrase structure rules for compound complex nouns and noun stems with pMOD heads are as given below.

(12.68) $N \rightarrow NP'_{nCTRL} - N'_{pMOD}st$

(12.69) $N\ st \rightarrow \begin{matrix} \alpha INAL \\ \beta ALN \\ \gamma MOD \\ \delta ARG \\ \epsilon CTRL \end{matrix} NP'_{\alpha INAL} - \begin{matrix} N'_{\beta ALN} \\ N'_{\gamma MOD} \\ N'_{\delta ARG} \\ N'_{\epsilon CTRL} \end{matrix} st$

An example of a compound complex noun with a pARG elementary noun stem head is given in (12.70) below. The head takes the preceding person prefix or NP as its argument. This construction is very productive.

(12.70)T botop men-ga-p 'rat trap'
 rat seized-cause+become-nz
 | |
 N' N'st
 | |
 NP' pARG
 | /
 NP /
 / /
 N /

Elementary noun stems which are pARG are always negative for the other three nominal construction type features: nINAL, nALN, and nMOD. They have no corresponding elementary nouns. They are distinguishable from pINAL stems semantically and are far more productive of compound complex nouns.

Most elementary noun stems which are pARG are nominalizations, but some are not. The clear examples of non-derived stems are given below.

(12.71)	N'st pARG	2s-N'st pARG
Gloss		
time period after argument	ábep	ęé-bep
something in front of argument	ájerê	ęé-jerê
owner of argument	ijaâc	ęè-jaâc
desire for argument	kakĩc	ę-gakĩc
sign or omen of argument	kázóp	ę-gázóp
eater of argument	ót	e-'-ót
message about argument	pásét	ę-básét

Of these, ijaâc 'owner', and ót 'eater' are possibly actor nominalizations of verb stems no longer extant.

All three Gavião nominalizing suffixes form pARG elementary noun stems, though two of them also produce nARG elementary noun stems. Nonsubstantive, abstract nominalizations are formed from elementary verb stems or elementary verbs by the suffix //-ve// (underlined):

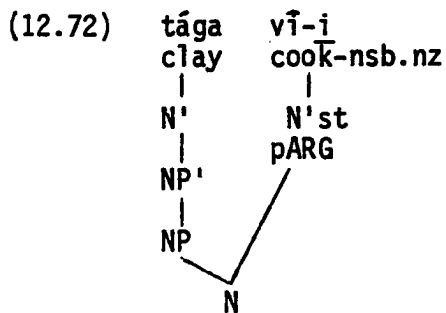

'firing (pottery) clay'

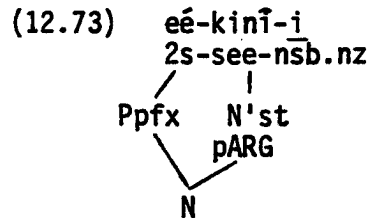

'meeting you' ('seeing you')

The pARG nominalizations take as their arguments the same NPs or person prefixes which could be arguments of the verb stem which has been nominalized. In (12.72), tāga 'clay' can be the subject argument of the intransitive cross-referencing verb stem viĩ 'cook, get cooked'. In (12.73), the person prefix eé- 'second person singular' can be the object of the transitive verb stem ákinĩ 'see'.

There is one example of a pARG noun stem formed from an adjective stem (q̄op 'nonexistent') by // -ve//:

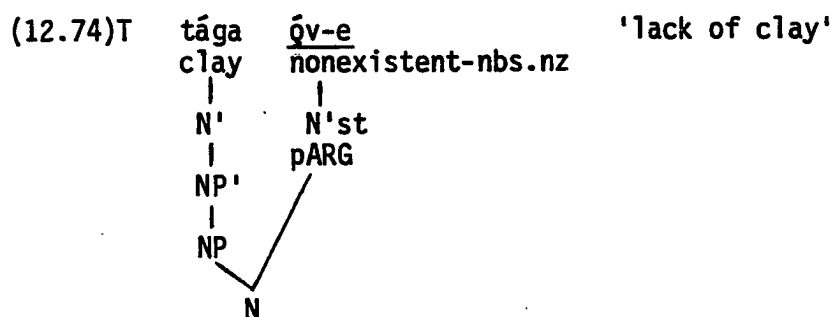

Some of the elementary noun stems formed with the nominalizing suffix // -p// are 'event' nominalizations and some are substantive. All of the 'event' stems are pARG and some of the substantive stems (such as men-ga-p 'trap' in (12.70) above) are pARG also. An 'event' example:

(12.75)T "q̄á koc té e-zá-á" té-teé tá-mâa
 this at nasr 2s-nasr-s.m only 3p-pPST+asr

q̄-gac, aa-kinĩ-p koc
 1s-involve 3c-see-nz at

'They just said, "You're here?" to me upon (my) seeing them.'
 (A Gavião meets the Cinta Larga Indians for the first time.)

Structure of the compound complex noun in (12.75):

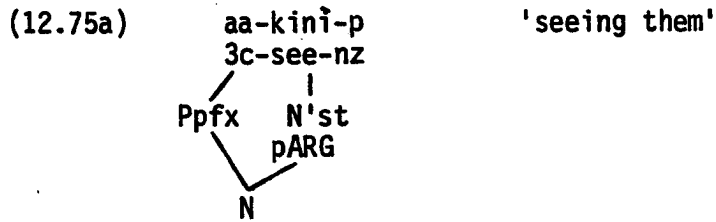

The actor suffix, *//-t//*, derives pARG elementary noun stems:

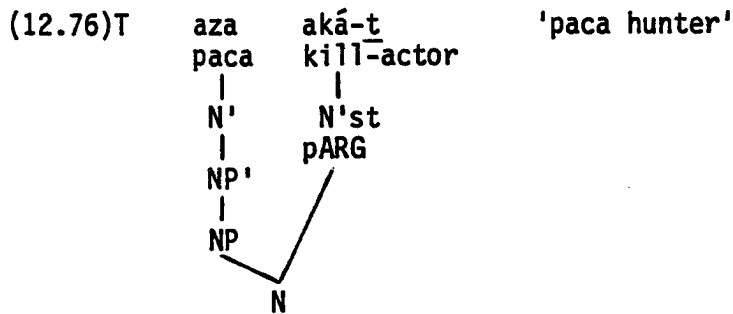

The pARG elementary noun stems form only compound complex nouns, not noun stems. However, if the compound complex noun begins with an elementary noun which accepts the possessor prefix, *mā-*, then an alienably possessed compound complex noun stem can be derived:

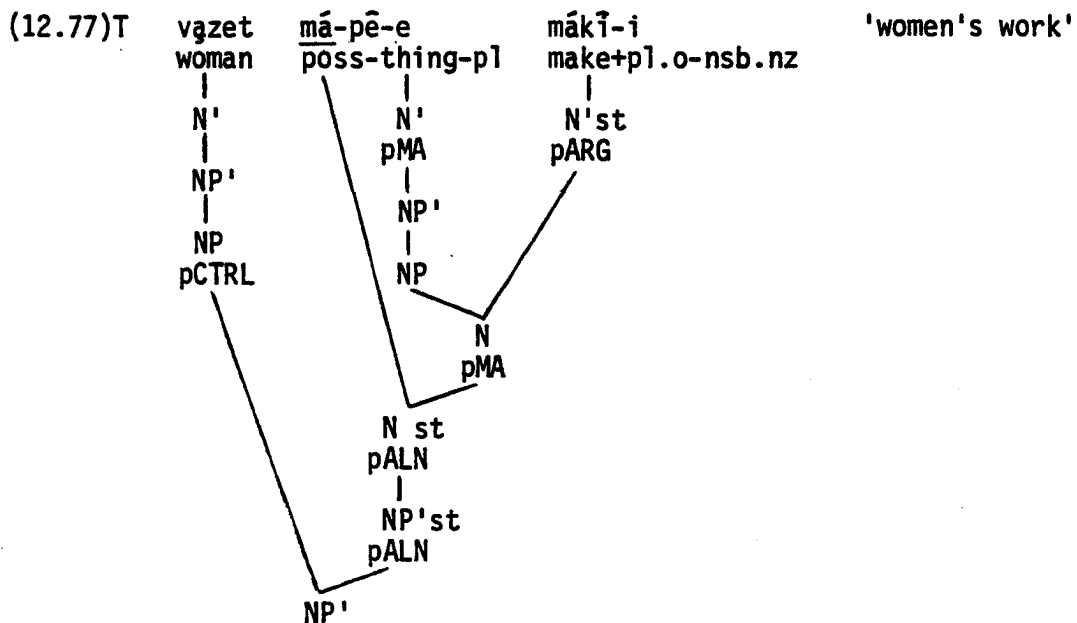

Because of the translation it is clear that the speaker intends the constituent structure of (12.77) to be as indicated, though formally a different constituent structure, giving the translation 'making women's things' is also possible.

Compound complex nouns with pARG heads very frequently modify pMOD noun stems:

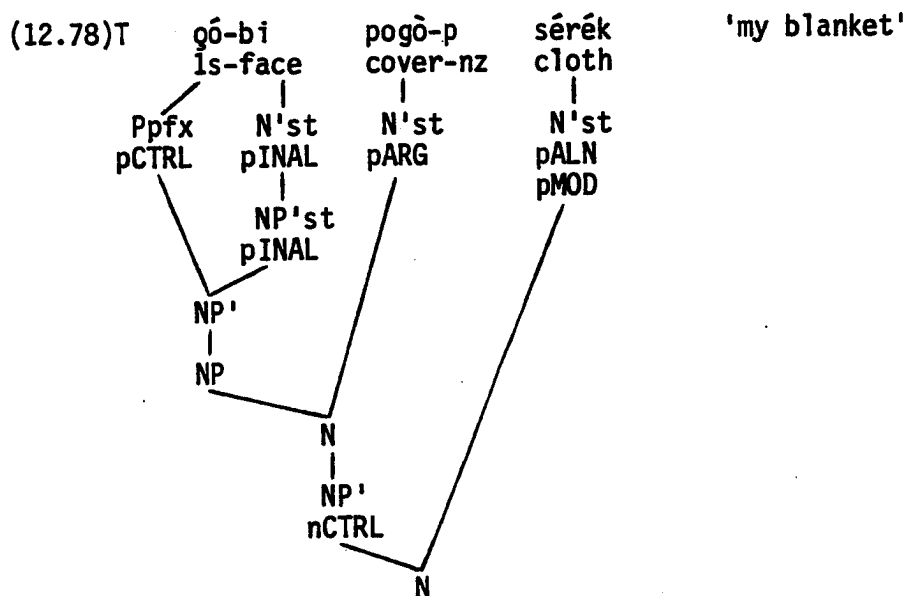

Phrase structure rule (12.79) generates compound complex nouns with pARG heads:

$$(12.79) \quad N \rightarrow \left\{ \begin{array}{l} NP \\ Ppfx \end{array} \right\} - N'st_{pARG}$$

Phrase structure rule (12.80) accounts for the derivation of pALN stems from compound complex nouns. The feature MA indicates whether the noun accepts the prefix má-.

$$(12.80) \quad N_{st} \rightarrow \underline{má-} - N_{pMA}$$

There are a couple examples of what appear to be compound complex nouns formed from an elementary noun or noun stem followed by an elementary adjective stem:

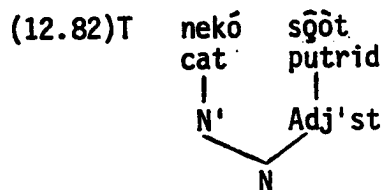
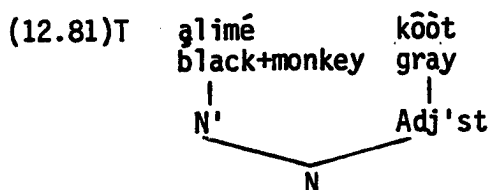

'gray monkey' ('macaco barrigudo') 'a kind of opossum' ('mucura')

These will be accounted for by phrase structure rules (12.83) and (12.84):

(12.83) $N \rightarrow N' - \text{Adj'st}$ (rare)

(12.84) $N \text{ st} \rightarrow N'\text{st} - \text{Adj'st}$ (rare)

α INAL	α INAL	
β ALN	β ALN	
γ MOD	γ MOD	
δ ARG	δ ARG	

12.4.2 Measure and Indefinite Constructions

Measure and indefinite constructions are infrequent and no good analysis of them can be offered without more data. There are two types of measure expressions: (1) numbers, which (except for môõc 'one') are compound complex words of diverse composition, and (2) measure expressions derived from pPROX demonstratives by suffixation, which are elementary words. Some number examples:

(12.85) 'one' môõc
 one

 'two' paá-ja-káap
 lpi-eye-s.r.o

'three'	ǵá this (one's)	sáno brother	ǵòp nonexistent
'four'	ǵá this (one's)	sáno brother	píra mát with sb.nz
'five'	móòc one	pábe hand	
'six'	móòc one	ma'ǵ get	pa-bábe pí lpi-hand from

The two suffixes which derive measure expressions are -náp ~ -nap (conditioning factor for the tone is undetermined) 'number, count' and -nát 'amount, extent'. The words formed by these suffixes do not seem to be demonstratives because they do not modify a following NP nor appear in sentence-initial demonstrative phrases.

Both types of measure expressions distribute like nouns in that they can occur as minimal NPs. Sometimes they form compound complex nouns by modifying a following noun stem, but sometimes this is ungrammatical. For example, of the numbers, 'one' can modify a following noun stem, even if the stem is inalienably possessed, but 'two' cannot necessarily modify the same stem:

- (12.86)A móòc pábe 'five'
one hand
- *paá-ja-káâp pábe 'two hands'
lpi-eye-s.r.o (=two) hand

Likewise, the measure expressions derived by suffixation can modify some noun stems:

- (12.87)A á-náp áâp té taâj-á
which-number holw.o nasr 3s-(pCOP+nasr)-s.m
- 'How many rooms is it?' (house)

However, some noun stems cannot be so modified:

- (12.88)A *á-náp vít 'How much food?'
 which-number food
- *á-nát vít 'How much food?'
 which-number food

No composition rule can be given for numbers. Rule (12.89) simply states that the numbers above 'one' are complex measurement nouns:

- (12.89) N → Numbers >1
 pMEAS

Rule (12.90) indicates that the measure expressions form complex nouns with some following elementary noun stems, but the selectional restrictions are undetermined:

- (12.90) N → $\left. \begin{array}{c} N' \\ N \end{array} \right\} - N'st$
 pMEAS ???

Numbers also distribute like verbs, meaning 'number of times':

- (12.91)T paá-ja-kíí teé máa a-kerè-p
 ípi-eye-s.r.o+dm (=two) cont (3s)-asr 3c-sleep-nz
- pā-la kíí
 go+out-pl.X ints

'It sleeps twice.' (letting chicha ferment for two nights)

The measurement expressions derived from demonstratives also distribute like verbs:

- (12.92)T méne ká bó tá-máa "á-nát teé té
 that in tz 3p-pPST+asr which-amount cont nasr

ve sã-ã" ãã
it nasr-s.m s.m

'Then they asked, "How far is it?"'

Rule (12.93) indicates that the numbers above 'one' are complex verbs (as well as complex nouns):

(12.93) V ← Numbers >1

Like the measurement expressions, the indefinite nPROX demonstrative, mã 'some, other', can sometimes (but not always) modify a following noun stem:

(12.94)T té tá-jé-e-na, méep, mã
(Q) nasr 3p-pPST+nDEF+uDUR+nasr-th-1k hesitation some

vã kã teé máge-é-na, gã pa-bére mi teé eé-na
hole in cont make-th-1k this lpi-nature use cont th-1k

'Did they make them, uh, in a hole like we do?'

(12.95)T eé téét ma-káã mã népo.
 then exct (3s)-pPST+asr-go other arm (=branch)

ágãã-niî-ã
support-?-s.m (=alight on)

'Then he went onto another branch.' (same tree)

These constructions are odd because they seem formally indistinguishable from possessive constructions such as:

(12.96)T mã ája-kããp 'other person's eye'
 other (one's) eye-s.r.o

In (12.97) below the demonstrative mã possesses a noun stem. In (12.98) below it modifies a noun. The indefinite constructions in (12.94) and (12.95) above are formally like (12.97) or (12.96), but

semantically like (12.98):

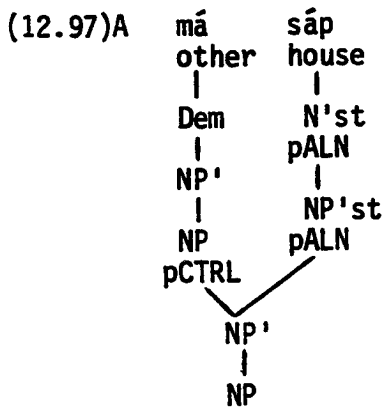

'other's or someone's house'

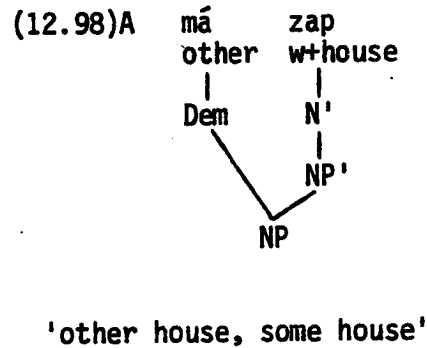

The behavior of indefinite constructions such as (12.94) and (12.95) cannot be determined from the data at hand. Rule (12.99) states only that the indefinite demonstrative forms complex nouns with some following elementary noun stems, but the selectional restrictions are undetermined:

(12.99) $N \rightarrow \underline{má} - N'st$
 ???

12.4.3 Compound Complex Adjective Stems

There are two clear examples of compound complex adjective stems:

(12.100)T "pa-bocôôc pátââ pê-a kólólôök vîri tá-sop
 lpi-thin chest flat-ish skinny walking+dm 3p-father

mââ tá-kalà-p koj-á" kí-po-á ñáá
 pCOP+asr 3p-want-nz at-s.m ev-rm.pst-s.m introduce+topic

'Their father was going around skinny and sunken-chested, missing them.'

(12.101)A pakop qôp mââ
 (3s)-strength nonexistent (3s)-pCOP+asr

'He's weak.'

These are accounted for by phrase structure rule (12.102):

(12.102) Adj st → N'st - Adj'st (rare)

12.4.4 Compound Complex Verb Stems

There do not appear to be any compound complex verbs (other than numbers) or any compound complex transitive verb stems. However, compound complex cross-referencing verb stems are formed by two very productive processes: NP' stem incorporation and adjective stem incorporation.

12.4.4.1 NP' Stem Incorporation

Three examples of NP' stem incorporation are given below. The compound complex cross-referencing verb stems are underlined and cross-referencing agreement is indicated by a dotted line.

(12.103)T pa-vít vii té pa-zá eé pí kac
 lpi-food cook nasr lpi-nasr that beyond (3s)-involve
 └──────────────────────────┘
 'After that we cook our food with it?' (pot)

(12.104)T bó máã a-posãã vaneè-á
 already (3s)-pPST+asr 3c-wing come+out-s.m
 └──────────────────────────┘
 'He was already sprouting wings.' (Hawkman's transformation)

(12.105)T eé-na "gêjé-p sot paã teé té-a
 th-1k 1s+dream-nz bad go+out cont nasr-1s+nasr
 └──────────────────────────┘
 kí-bó-á" eé téét tá-párãã éêt kí-nap
 ev-rm.pst-s.m then exct 3p-good pPST+pDEF+pSJV+asr ev-ndef.tm
 'Then the best one of them said, "I'm having bad dreams."'

Compare an elementary cross-referencing verb stem to a compound

complex cross-referencing verb stem formed by NP' stem incorporation:

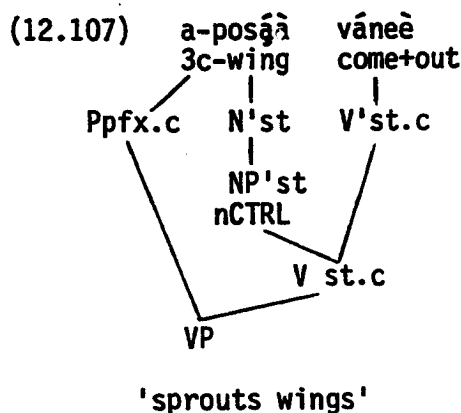
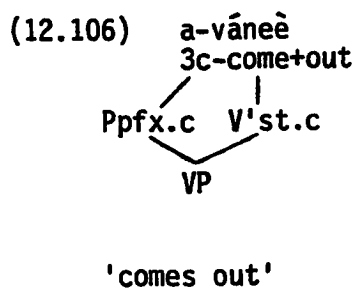

The incorporated nominal stem is considered to be a NP' stem, not just a noun stem, since adjective stems can potentially occur within it, as in (12.05) above. The incorporated NP' stem is always noncontrolling. It can always be the NP' stem of a possible subject NP argument of the head elementary cross-referencing verb stem. For example, the incorporated NP' stem in (12.104) is the elementary noun stem pôsââ 'wing', which occurs as the possessed NP' stem in the subject NP in (12.108) below. The verb stem váneè occurs in the predicate:

(12.108)A ci-posââ mää a-váneè
 3s-wing pPST+asr 3c-come+out

'His wings sprouted.'

This last selectional restriction is not formalized in phrase structure rule (12.109) below, which generates compound complex cross-referencing verb stems formed by NP' stem incorporation:

(12.109) V st.c → NP'st - V'st.c
 nCTRL

12.4.4.2 Adjective Stem Incorporation

Three examples of adjective stem incorporation are given below. The compound complex cross-referencing verb stem is underlined and cross-referencing agreement is indicated by a dotted line.

(12.110)T aáv-á eé téét tó-máa tó-bi'aá jì-á
 yes-s.m then exct lpe-pPST+asr lpe-tangled enter-s.m
 'Yes. Then we fell in tangled up.' (A canoe capsized.)

(12.111)T gó alóp máa a-mapir-aá abá-léèt-tá
 aff 3s pPST+asr 3c-child-with suspended-pl.X-be
 'She was pregnant, bulging.'

(12.112)T tó-dátkáp váneè tó-máa
 lpe-naked+pl come+out lpe-pPST+asr
 'We came out naked.'

Compare an elementary cross-referencing verb stem to a compound complex cross-referencing verb stem formed by adjective stem incorporation:

(12.113) tó-váneè
 lpe-come+out
 Ppfx.c V'st.c
 VP
 'come out'

(12.114) tó-dátkáp váneè
 lpe-naked+pl come+out
 Ppfx.c Adj'st V'st.c
 VP
 'come out naked'

According to informants there is no limit on the number of adjective stems which can be incorporated into one compound complex cross-referencing verb stem. Locative adjective stems follow any others.

The incorporated adjective stems describe the subject of the clause. Example (12.115) below seems to be essentially equivalent semantically to (12.110) above:

(12.115)A eé téét tó-bi'aá mää tgo-'-jì-á
 then exct lpe-tangled pPST+asr lpe-enter-s.m

'Then we fell in tangled up.'

Phrase structure rule (12.116) below revises rule (12.109) above so as to include adjective stem incorporation.

(12.116)

$$V \text{ st.c} \rightarrow \left\{ \begin{array}{l} \text{NP'st} \\ \text{nCTRL} \\ \{ \text{Adj'st} \}^+ \\ \{ \text{Adj st} \} \end{array} \right\} - V \text{ 'st.c}$$

12.5 Summary of Phrase Structure Rules for Complex Words and Complex Word Stems

The rules for the composition of the complex words and complex word stems given in section 12.0 are summarized below. The number of each rule as it originally appeared is given to the right. When two rules are collapsed both numbers are given. Rules of low productivity are marked 'rare'. Glosses are provided inside single quotes under the line.

N st → mā- - N (12.80)
 pALN 'poss' pMA

	$\left\{ \begin{array}{l} N'st \\ \alpha INAL \\ \beta ALN \\ \gamma MOD \\ \delta ARG \end{array} \right\} - \left\{ \begin{array}{l} N'st \\ pINAL \\ Adj'st \end{array} \right\}$	(12.60) (rare)
	$\left\{ \begin{array}{l} NP'st \\ \alpha INAL \\ \beta ALN \\ \gamma MOD \\ \delta ARG \\ nCTRL \end{array} \right\} - N'st$	(12.84) (rare)
$N \rightarrow$	$\left\{ \begin{array}{l} \alpha INAL \\ \beta ALN \\ \gamma MOD \\ \delta ARG \end{array} \right\} - \left\{ \begin{array}{l} NP'st \\ \alpha INAL \\ \beta ALN \\ \gamma MOD \\ \delta ARG \\ nCTRL \end{array} \right\} - N'st$	(12.69) pMOD

	$\left\{ \begin{array}{l} S' \\ nomS.F.TY \\ VP \end{array} \right\} - \left\{ \begin{array}{l} \underline{m\acute{a}t} \\ 'sb.nz' \\ \underline{m\acute{e}ne} \\ 'nsb.nz' \end{array} \right\}$	(12.12)
	Dem - <u>tigi</u>	(12.49)
	pPROX - 'p'lace'	
	$N' - \left\{ \begin{array}{l} N'st \\ pINAL \\ Adj'st \end{array} \right\}$	(12.59) (rare)
	$NP' - N'st$	(12.83) (rare)
	nCTRL - pMOD	(12.68)
$N \rightarrow$	$\left\{ \begin{array}{l} NP \\ Ppfx \end{array} \right\} - N'st$	(12.79) pARG
	$\left\{ \begin{array}{l} N' \\ N \end{array} \right\} - N'st$	(12.90) ???
	<u>m\acute{a}</u> - N'st	(12.99) ???
	'other' - ???	

$N \rightarrow$ Numbers >1 (12.89)
pMEAS

	$\left\{ \begin{array}{l} V'st - \underline{d\acute{e}\hat{e}} \\ 'pst.prt' \end{array} \right\}$	(12.27)
Adj st \rightarrow	$\left\{ \begin{array}{l} N'st - Adj'st \end{array} \right\}$	(12.102) (rare)

V st.t →	$\left\{ \begin{array}{l} V'st - \frac{ma-téé}{'cause'} \\ \\ Adj'st - \frac{tígi}{'cause'} \\ \\ \left\{ \begin{array}{l} N'st \\ pEVENT \end{array} \right\} \\ \\ \left\{ \begin{array}{l} Adj'st \end{array} \right\} - \frac{tígi}{'time'} $	(12.32)
		(12.34)
		(12.45)

V st.c →	$\left\{ \begin{array}{l} NP'st \\ nCTRL \\ \\ \left\{ \begin{array}{l} Adj'st \end{array} \right\}^+ \\ \\ \left\{ \begin{array}{l} Adj st \end{array} \right\} \end{array} \right\} - V'st.c$	(12.116)
----------	---	----------

V →	$\left\{ \begin{array}{l} NP - \frac{ná}{'vz'} \\ \\ Utterance/Thought - \underline{-á} \\ \\ V' - \frac{ma-téé}{'cause'} \\ \\ \left\{ \begin{array}{l} N' \\ N \end{array} \right\} \\ nSB \\ nFIN \\ \\ \left\{ \begin{array}{l} N' \\ pEVENT \end{array} \right\} \\ \\ \left\{ \begin{array}{l} Dem \\ nPROX \end{array} \right\} \\ \\ Dem \\ nPROX \\ \\ Numbers >1 \end{array} \right\} - \frac{tígi}{'cause'}$	(12.16)
		(12.24)
		(12.31)
		(12.38)
		(12.46)
		(12.50)
		(12.93)

APPENDIX A: PHONOLOGY

1.0 The Orthography

The consonant and vowel orthography is essentially a surface (taxonomic) phonemic transcription, though nasalization in Gavião does not lend itself well to surface phonemic analysis and the surface palatal contrasts are probably underdifferentiated. The tone orthography is a low-level morphophonemic transcription which is in the spirit of a surface phonemic analysis in that it recognizes the minimal number of contrasts needed to distinguish utterances without extensive grammatical information.

1.1 Orthographic Symbol InventoryConsonants:

	p	t	k	'
Stops:	b	d	g	
	s	c		
Affricates:	z	j		
Fricative:	v			
Nasals:	m	n	ñ	ḡ
Liquids:		r	l	(y)

Vowels:

i	+
e	o
	a

Nasalization: ~

(Nasalization is not marked on nasal vowels adjacent to nasal consonants.)

Junctures: _ closed internal juncture

-- open internal juncture

Tones:

Short:

˘ high

Long alternating:

˘˘ high

Short:

ˆ rising
 ˘ low (no diacritic)
 ˘ alternating

Long alternating:

ˆˆ rising
 ˘˘ low

Long constant:

ˆˆ high
 ˆ rising
 ˘ low (no diacritics)
 ˘ falling
 ˆ˘ rising-falling

1.2 Stops and Corresponding Nasals

Phonetically, p, t, and k are bilabial, dental, and velar voiceless stops, respectively; b, d, and g are bilabial, dental, and velar voiced stops, respectively; and m, n, and ŋ are bilabial, dental, and velar nasals, respectively. Of these only the voiceless stops occur word-finally. They are rather faint and entirely unreleased then. All stops (except the glottal stop) are somewhat prenasalized word-medially following nasal vowels. The voiceless stops are strongly prenasalized word-finally. The glottal stop, ' , occurs only word-medially.

1.3 Dental Affricates

Phonetically, s and z are voiceless and voiced dental affricates with grooved dental fricative release. They only occur word-initially and word-medially.

1.4 Palatals

A symbol y is included in the inventory chart in parentheses

because it should probably be considered one of the surface phonemes. I know of no minimal pairs which necessitate distinguishing a surface phoneme /y/ from the palatal phonemes /c/, /j/, or /ñ/, and because of free variation any instance of /y/ could always be phonetically identical or very similar to another palatal phoneme. Without more information on free variation in the palatal phonemes a better analysis of them than is given in the orthography cannot be established with certainty. The phonetic value of the orthographic symbols is given below, followed by a hypothesis about /y/.

The symbol c is a voiceless palatal affricate with a slit fricative release word-initially and between vowels. Between vowels it is also prepalatalized. Before consonants and word-finally it is a palatal glide which finishes as a brief unreleased voiceless palatal stop. The glide portion is nasalized after nasal vowels.

The symbol j is a voiced palatal affricate with a slit fricative release word-initially. It can always have this quality intervocally, but then in many instances it can optionally be a voiced palatal slit fricative or a palatal glide. Before consonants it is a palatal glide finishing as a brief voiced palatal stop.

The symbol ñ is a palatal nasal word-initially. It can always have this quality intervocally, but then in many instances it can optionally be a nasalized voiced palatal slit fricative or a nasalized palatal glide. Before consonants it is a nasalized palatal glide which finishes as a palatal nasal.

As a hypothesis, a better analysis would postulate a /y/ phoneme in place of (1) c preconsonantly and word-finally, (2) j preconsonantly and when it shows free variation intervocally, and (3)

ñ preconsonantly and when it shows free variation intervocalically.

1.5 Fricative

The bilabial voiced fricative, v, occurs word-initially and word-medially. When initial preceding a nasal vowel it is nasalized. Medially it may or may not be nasalized following or preceding a nasal vowel.

1.6 Liquids

The dental flap, r, is always voiced and occurs only word-medially. Some speakers have nasalized allophones of r. The lateral, l, is somewhat retroflexed. It occurs only word-medially and word-finally. When final it ends in a brief unreleased homorganic voiceless stop. It is nasalized when medial between nasal vowels or when preconsonantal or word-final and preceded by a nasal vowel.

1.7 Vowels

The vowels form an asymmetric set of five. Each can occur either word-initially, word-medially, or word-finally, except that ɨ is never word initial unless it is the diminutive of an underlying //a//. These are described phonetically below in order of descending frequency.

The low central vowel, a, has much the same phonetic quality as its English equivalent. It is sometimes slightly raised, especially in closed syllables. The rounded mid back vowel, o, is close in phonetic quality to its Portuguese equivalent, ô. It is occasionally raised somewhat, but never quite as high as, say, the back vowel in English 'put'. The high front vowel, i, approximates its Portuguese equivalent in phonetic quality. It is optionally lowered in some

syllables, especially closed syllables. The mid front vowel, e, falls phonetically between the two English mid front vowels and is very close to the higher Portuguese mid front vowel, ê. The unrounded high central vowel, ɨ, ranges between high and mid-high but is always central.

Oral vowels contrast with nasal vowels, but each oral vowel differs from its corresponding nasal vowel only in nasalization; otherwise the phonetic quality is the same.

1.8 Tone and Length

Length is considered to be an aspect of the tone system. There are three groups of tones recognized in the orthography: short tones, long alternating tones, and long constant tones. Some tones cause immediately following high tones to be downstepped to mid height.

There are no restrictions on the distribution of the high and low short tones, but the rising short tone is comparatively infrequent and can appear word-finally only in monosyllables. The alternating short tone occurs only word-finally. Short tones:

- ˆ high short
- ˆ rising short, optionally mid short immediately following a high tone, in which case it causes downstep
- low short
- ˆ alternating short: low immediately preceding high tones and silence, optionally high immediately preceding nonhigh tones

The long alternating tones are very common, especially word-finally. Long alternating tones:

- ˆˆ high long alternating: falling from high to low before silence;

long high elsewhere, causing downstep

ˊˊ rising long alternating: rising from low to mid and falling back to low before silence; elsewhere rising from low to high, causing downstep

ˊ low long alternating: long low before silence and high tones; optionally rising from low to high before nonhigh tones

The long constant tones do not show the conditioned phonetic variation of the long alternating tones. The high and the rising long constant tones are common, but the others are rather infrequent. Long constant tones:

ˊˊ high long constant

ˊ rising long constant: rising from low to high

ˊ low long constant

ˋ falling long constant: falling from high to low

ˊˋ rising-falling long constant: rising from low to mid and falling back to low, causing downstep

2.0 Systematic Phonology

Very brief characterizations of some major aspects of Gavião systematic phonology are given below.

2.1 Inventory of Consonants and Vowels

The inventory of systematic segmental phonemes is the same as the surface (orthographic) inventory except that the velar nasal, ŋ, and the palatal affricates and nasal, c, j, and ɲ, do not exist at the systematic phonemic level. The palatal glide, //y//, does.

The velar nasal is derived exclusively from morpheme-final //k//

preceded by a nasal vowel. The palatal affricates, c and j, appear to have three sources: (1) dental affricates //s// and //z// palatalized by an immediately adjacent //i// or //y//, (2) dental affricates or stops which have been diminutivized, and (3) the palatal glide, //y//, which becomes c when preceding an open juncture or when oral preceding voiceless consonants, and which becomes j when oral elsewhere. The palatal ñ derives exclusively from //y// when nasalized and not preceding open juncture. The j and ñ derived from //y// are optionally phonetically glides morpheme-noninitially between vowels.

Morpheme-initially all systematic phonemes occur except //ɨ//, //ʻ//, //l//, and //r//. Morpheme-medially all systematic phonemes occur. Only the palatal glide, //y//, occurs preceding other consonants within the morpheme. There are a few instances of //ʻ// morpheme-medially; elsewhere the surface glottal stop is the phonetic manifestation of internal open juncture intervocalically. Morpheme-finally only the voiceless stops //p//, //t//, and //k// and the liquids //r//, //l//, and //y// occur. Of these, //r// is very marginal morpheme-finally; it is recoverable only in the plural action and adjective plural suffixes.

2.2 Nasalization

Nasal consonants //m// and //n// and autonomously nasal vowels occur as systematic phonemes. Nasalization from any of these spreads to the left and right within the morpheme until it is blocked by an obstruent. Nasalization can continue to the right across closed internal juncture into the next morpheme under certain conditions which are difficult to summarize.

2.3 Consonant Rules

The phonological rules altering consonants apply only within a morpheme or across a closed internal juncture. The major phonological rules affecting segmental phonemes are given briefly and rather crudely below in an ordered sequence. These affect consonants; the vowels are remarkably stable. Nasalization spread interacts with the segmental rules in an interesting way, though this is left aside. Rules:

- (1) //p// deletes before //m// and //v//.
- (2) //m// and //v// delete following consonants.
- (3) Morpheme-final voiceless stops //p, t, k// become:
 - (a.) voiced stops b, d, g when preceded by an oral vowel and followed by a voiced consonant;
 - (b.) nasals m, n, ŋ when preceded by a nasal vowel and followed by a consonant;
 - (c.) continuants or voiced stops v, r, g when preceded by an oral vowel and followed by a vowel;
 - (d.) nasalized continuants or nasals ṽ, ñ, ŋ̃ when preceded by a nasal vowel and followed by a vowel.
 (Elsewhere the voiceless stops //p, t, k// are unchanged.)
- (4) Voiceless consonants //p, t, k, s// become voiced b, d, g, z following nasal sonorant consonants and certain person prefixes.
- (5) Dental affricates //s, z// become palatal affricates c, j when immediately adjacent to //i// or //y//.
- (6) The initial consonant of a homorganic consonant cluster deletes.
- (7) The palatal glide //y// becomes c, j, or ñ, as explained in Section 2.1 of this appendix.

2.4 Systematic Tone Phonemes

At the systematic phonemic level there are four or perhaps five fewer tone phonemes than there are in the surface orthography. The alternating short tone appears to be a variant of the low short tone, produced when low short tone vowels are reduplicated by a stem formative process, e.g. kerè 'sleep'. The low long alternating tone is a fusion of a low short tone and an alternating short tone (e.g. káqàà 'get dry'), or else is the stem-final variant of the low long constant tone (e.g. ciit 'blood'). The rising short tone is almost always derived from shortened rising long tones or from the fusion of a 'floating' low tone and a following high tone, but there are some cases I cannot explain in this fashion. The falling and rising-falling long constant tones appear to be derived from tone fusion.

There are important grammatical restrictions on the distribution of systematic tone phonemes. With very few exceptions long tones occur only morpheme-finally. Noun roots must be analyzed synchronically as often having long final tones, but in general adjective roots and verb roots have short final tones which are lengthened by stem formative processes.

2.5 Tone Rules

Some low-level tone rules were given above in the description of the phonetic quality of the orthographic tone symbols. Other tone rules fall into three groups: (1) tone fusion, (2) tone raising and lowering, and (3) tone shortening and lengthening.

Tone fusion results mainly from syllable merger across internal closed juncture or syllable merger due to consonant deletion. The

resulting syllable has a maximum length of two moras. Fusion rules are numerous due to the large number of possible combinations and cannot be stated briefly.

Tone raising and lowering is for the most part grammatically conditioned. In particular, some person prefixes raise or lower stem-initial syllables, the transitivizing prefix may raise the tones of a whole stem, and cross-referencing verb roots of the //é-// and //è-// prefix classes contain only low tones.

Lengthening and shortening rules affect elementary nouns and noun stems in particular, operating between but not across external open junctures:

- (1) In elementary noun stems which are usually possessed (and in their corresponding nouns, if any), underlying long tones are shortened unless they occur finally before an open external juncture.
- (2) In elementary noun stems which are not usually possessed and in their corresponding nouns, underlying long tones followed by short tones become short.
- (3) In most bisyllabic noun stems which are not usually possessed and in their corresponding nouns, initial underlying short tones become long when followed by a long tone.

APPENDIX B: MORPHOLOGY

The brief sketch of Gavião morphology given below attempts to state only the main facts of person prefixation and the principal composition patterns of elementary word stems and elementary words. Particles, which have little morphology, are left aside. Auxiliary stem morphology is discussed in Section 6.2 above.

Stems differ from simple roots in that stems may contain more than one morpheme and are necessarily potentially free forms (potentially pronounceable in isolation and potentially bounded by open external junctures), whereas roots are monomorphemic and may be either potentially free (in which case they are also stems) or always bound. A complex root is a construction which contains a root and one or more other morphemes and which functions like a simple root.

Most roots belong to only one form class, but some belong to two or more. For example, the base form //sq̃t// is a noun root, an adjective root, and a cross-referencing verb root. It appears (1) with no stem formative as a noun stem, sq̃t 'putrid substance', (2) with the adjective stem formative //V̂V̂// as an adjective stem, sq̃òt 'putrid', and (3) with the //V̂̃// verb stem formative as a cross-referencing verb stem, sonò 'putrefy'.

1.0 Person Prefixation

The four person prefix classes are illustrated below with noun stems. Person prefixation is also discussed and illustrated in Section 3.3 above.

Class	//é-//	//e-//	//eé-//	//éè-//
Gloss	'hand'	'smell'	'mat'	'sister'
Base	//pábe//	//ka//	//ákápe//	//paàt//
Postnominal	pábe	ka	ákápe	paàt
1s	bábe	ǫ-ga	oó-kápe	ǫò-baàt
2s	ɛ-bábe	ɛ-ga	eé-kápe	éè-baàt
3s	ci-pabe	ci-ka	saa-kápe	cii-paàt
3c	a-pabe	a-ka	aa-kápe	aa-paàt
1pi	pa-bábe	pa-ga	paá-kápe	paa-baàt
1pe	tó-pábe	tó-ka	tóó-kápe	tóò-paàt
2p	me-pábe	me-ka	meé-kápe	mee-paàt
3p	tá-pábe	tá-ka	táá-kápe	táa-paàt

There are two types of stems which begin with vowels. The first type begins with a monosyllabic morpheme. Person prefixes are joined to stems of this type by open internal juncture (e.g. e-'-ót 'something which eats you'). These stems may belong to any person prefix class except //eé-//. The second type begins with a morpheme which is not monosyllabic (e.g. ákápe 'mat' above). In these cases the initial vowel (//a// or //i// only) is deleted when preceded by a person prefix. All //eé-// class stems are of this type, and some//éè-// class stems are also.

It appears that initial //i// in the second type of stem is being regularized to a in Gavião, though older speakers use i. For older speakers stems of the second type which begin with //i// select person prefix allomorphs (except for the third person) which end in //y//, e.g. //oóy-// in oóc-kinĩ 'see me'. This is oó-kinĩ for younger

speakers.

When the initial segment of the base form of a stem is an obstruent it is almost always voiceless, though there are some voiced exceptions. The initial obstruent becomes voiced after the first person singular, second person singular, and first person plural inclusive prefixes. These same three prefixes then become nasalized preceding (1) stem-initial voiced obstruents or (2) stem-initial nasal consonants or vowels.

A stem of the //é-// or //éê-// person prefix classes never has high initial tone in its base form. The base form of an //e-// or //eé-// class stem may have either high or nonhigh initial tone, but following a nominal expression (postnominal) or following most person prefixes the initial tone becomes high. This tone raising does not occur after the third person singular and third person coreferential/cross-referencing prefixes. The third person singular prefix allomorph //si-// and the third person coreferential/cross-referencing prefix //a-// usually lower the initial tone of a following noun stem to low, though stems of other form classes are unaffected.

Initial stem syllables are usually underlyingly short, but they may also be long in stems of any person prefix class except //eé-//. A few //e-// class stems select long prefix allomorphs, e.g. ee-zââ 'your lower leg'.

The third person singular prefix has three base allomorphs whose occurrence is partly phonologically conditioned, partly grammatically conditioned: //si-//, //sa-//, and //∅-//. The form ci- occurs on most noun stems of the //e-// and //é-// person prefix classes, though some of these have a zero prefix instead, e.g. sérék 'his skin'. The

zero prefix is usual for verb, adjective, and auxiliary stems of the //e-// and //é-// person prefix classes. The form cii- occurs on (1) //êè-// class stems which do not begin with //a// and (2) on //eé-// class stems which begin with //i// and whose second syllable has high tone (if low, cíi- occurs). On //eé-// and //êè-// class stems which begin with //a// the form taa- occurs if the first consonant is dental; otherwise saa- occurs.

2.0 Nouns and Noun Stems

The relationship between nouns and noun stems is explained in Sections 9.3.2 and 12.4.1 above. Noun stems are spoken of below since in general nouns have corresponding noun stems but the reverse is not true. Noun stems contain no stem formative morphemes, so all potentially free noun roots are noun stems.

The animate plural suffix, // -êèy//, occurs on animate nouns, on pronouns, or on demonstratives whose referent is animate. This suffix occurs on proper nouns with the meaning 'people of, group of', e.g. boobó-a-éèc 'people of the Waterfall Village'. There are numerous allomorphs of // -êèy//, some of which replace final stem syllables ending in -t, e.g. vazet 'woman', vazê-èc 'women'.

Compound noun stems can contain various combinations of noun roots or stems, such as two bound roots (e.g. géré-pâà 'spider'), two stems (e.g. basanà-m-gââp 'a kind of stone'), a bound root and a stem (e.g. maa-kââp 'peanut') or a stem and a bound root (e.g. bee-kââ 'clearing on a path'). A compound noun stem can also contain a complex noun root preceding a noun stem, the complex root consisting of either a bound noun root and noun stem (e.g. teeteer-ââv-aâ 'purple cará')

or a bound noun root and adjective stem (e.g. bákop--vóòv-aá 'red banana'). A few noun stems are composed of a noun stem and an adjective stem, e.g. pó-kââc 'fire'.

Three very productive suffixes derive noun stems or nouns from verb stems, verbs, or simple or complex verb roots. Event or substantive nouns or noun stems are derived with *//-p//*, e.g. kerè-p 'sleep', 'hammock', or 'bed'. The actor suffix *//-t//* (usually -t, sometimes -c) often raises the tone of the penultimate stem syllable, e.g. âkîni-t 'visitor'. The suffix *//-ve//* derives nonsubstantive nouns and noun stems from verbs and verb stems (e.g. ake-e 'killing') and derives noun stems from adjective stems (e.g. kar-e 'many things').

The prefix má- derives pALN, nMOD noun stems from nouns, e.g. má-bebe 'pig'. The prefix *//ma-//* derives pALN noun stems and nouns from some pINAL noun stems, usually those which can be eaten, e.g. ma-ñòòp 'meat'.

3.0 Adjective Stems

Most adjective stems are composed of a simple or complex adjective root and a stem formative morpheme, though some adjective stems are simple or complex adjective roots without a stem formative (e.g. sot 'bad, ugly'). An adjective root may be marked for plural, marked for singular, or unmarked for number.

Some unmarked roots may be marked for plural by a plural stem formative. The plural stem formative is a zero morpheme on adjective roots ending in a closed syllable (e.g. sóváp 'soft, plural') and is *//-rV//* (-r after front vowels, -l elsewhere) when the final syllable is open (e.g. patí-rí 'heavy, plural').

The nonplural stem formative, which is either unmarked for number or else singular, is usually tone suppletion, representable as // -V̂V̂ // since final high tones become high long alternating tones (e.g. sóvââp 'soft, singular') and final low tones become rising long alternating tones (e.g. parâât 'good'). A few roots which end in closed syllables and are unmarked for plural occur with a stem formative which is the // -V̂V̂ // tone suppletion followed by a reduplicated low tone vowel, // -V //, which shortens the preceding root-final syllable, e.g. kôro 'new'. A few adjective roots have a stem formative prefix, mâ-, e.g. mâ-góló 'many'.

There are three types of complex adjective roots (some of which are adjective stems by themselves, some of which occur with a stem formative): (1) a locative adjective root and the plural action suffix, // -êt // (e.g. tôr-êt 'attached, plural times'), (2) a noun stem and adjective root (e.g. pére-kôlo 'without anyone'), and (3) a simple or complex cross-referencing verb root and the adjective-deriving suffix // -p // (e.g. tê-p 'flowing full').

The suffix -aâ '-ish', 'characterized by' (plural: -âlâ) derives adjective stems from adjective stems (e.g. vév-aâ 'swollen'), from adjective roots (e.g. dañ-aâ 'dented'), or from noun stems (e.g. ci-'-aâ 'wet'). Two much rarer derivational suffixes, -at and -ââp, appear to be similar to -aâ.

4.0 Transitive Verb Stems

Most simple or complex transitive verb roots occur with the usual verb stem formative morpheme, // -V̂V̂ //, which reduplicates the last root vowel and its tone, except that a reduplicated low tone is an

alternating tone, e.g. kalâ 'want'. A few transitive verb roots occur as stems by themselves, e.g. va 'bite'. Likewise most postpositional transitive verb roots occur as stems with no stem formative morpheme, though some occur with a low tone reduplicated vowel stem formative, e.g. târa 'atop'. Verb stems and verbs ending in long vowels may be marked for plural action with the suffix *//-rV//*, e.g. nô-lo 'give, plural action'. Verb stems, verbs, and auxiliary stems all accept a suffix, *//-eé+na//* 'thus, like that', which is the bound form of the elementary verb eé-na (< eé 'that' + -na 'manner').

Almost all cross-referencing verb roots can be transitivized by the prefix *//ma-//* e.g. má-kejè 'dream of'. A few cross-referencing verb roots are transitivized by an infix of unpredictable form, e.g. po-ro-cójô, 'cause to get thin' (cf.: pocojô 'get thin'). A complex transitive verb root is composed of a noun root or noun stem followed either by a simple transitive verb root (e.g. âgââ-niî 'hop along on top of') or by a transitivized cross-referencing verb root (e.g. cí-ma-bqó 'cause to be full').

The derivational suffix *//-ka//* 'cause to become, singular action' derives transitive verb stems from adjective roots (e.g. ḍac--ka 'dent, singular action') or from adjective stems (e.g. kíit--ka 'cause to become white'). Its plural action counterpart, *//-a//*, which is less productive, also occurs on adjective roots (e.g. ḍañ-a 'dent repeatedly') or on adjective stems (e.g. cīḡ-a 'make small, plural times').

5.0 Cross-referencing Verb Stems

Simple or complex cross-referencing verb roots almost always

always occur with the $//-\overset{\alpha}{V}//$ stem formative morpheme, described above. Cross-referencing verb roots are productively derived from transitive verb roots by the intransitivizing prefix vé- (e.g. vé-aka 'get self killed'). Complex cross-referencing verb roots mostly consist of a simple cross-referencing verb root preceded by a noun root (e.g. cí-bqò 'get full'), or by a noun stem (e.g. vj-jon-baà 'fart').

The derivational suffix $//-tə//$ 'become' derives cross-referencing verb stems from adjective roots (e.g. palí-təè 'become good') or from adjective stems (e.g. abâà-təè 'become suspended'). The suffix -tá 'be' similarly occurs on adjective roots (e.g. pepó-ñé-dá 'take off flying, plural action') or on adjective stems (e.g. círôòc-tá 'be blue/green'). This suffix can occur on about half of the adjective stems, somewhat fewer than $//-tə//$.

6.0 Verbs

Some verbs are verb roots with no stem formative morpheme (e.g. méét 'long ago'). Some others are simple or complex verb roots with the $//-\overset{\alpha}{V}//$ stem formative morpheme. An example with a simple root is gí1í 'in the afternoon'. The complex verb roots can be (1) the word-deriving prefix, 'w', plus a transitive verb root with tones lowered (e.g. basanâ 'steal') or 'w' plus a cross-referencing verb root with tones lowered (e.g. gerè 'sleep elsewhere'), (2) a noun root and a transitive verb root (e.g. baa-toò 'chew up something and spit it out'), (3) a noun and a transitive verb root (e.g. bicaḡ-i 'at night'), or (4) the 'dummy noun' prefix $//ve-//$ and a transitive verb root (e.g. ve-mi 'well').

Many verbs are high tone verb roots with a verb formative suffix

-ã, e.g. kɪlɪgã 'bite'. The verb root may often be reduplicated to indicate repeated action, e.g. kɪc--kɪñã 'scratch repeatedly'. A few verbs are composed of a noun and a suffix -a, e.g. zaan-a 'make war' (cf.: zãt 'warrior').

Numbers (e.g. môc 'one') or measurement expressions derived from demonstratives (e.g. aã-nãp 'this many', aã-nãt 'this much') function as verbs or as nouns. The manner suffix, -na, derives verbs from pPROX demonstratives, e.g. aã-na 'like this'.

7.0 Diminutives

Gavião diminutivization is similar to that of Portuguese except that words and word stems of all form classes except particles can be affected. In general, roots, stems, and at least some derivational suffixes can be diminutivized. I have no examples of prefix diminutives, and some root or stem syllables seem impervious to diminutivization. Vowels are raised by diminutivization, except that there is no back vowel higher than o. Diminutive examples (second column):

vêre	<u>vîri</u>	'walking'
alã	<u>ɨlɨ</u>	'fall'
koñô	<u>koñô-ôt</u>	'dig'

Diminutivized dental affricates are palatalized:

sot	<u>cot</u>	'bad'
zôvãàp	<u>jôvɨɨp</u>	'ls-soft'

Usually, but not always, diminutivized word-final open syllables are closed with -t and tone suppletion replaces (1) high tones with

high long alternating tones and (2) nonhigh tones with rising long constant tones:

sā	<u>cí-ít</u>	Aux'st, nasr
māā	<u>mí-ít</u>	Aux'st, pCOP+asr
kalā	<u>k+lí-ít</u>	'like'
kaā	<u>kí-ít</u>	'go'

A few adjective stems have irregular diminutives, e.g.:

tóòt	<u>córoc</u>	'attached'
------	--------------	------------

APPENDIX C: AN ANALYZED TEXT

The following text, 'An Interview with Grandmother about Making Pottery', was recorded in June of 1977 in the house of Bojá ('Grandmother'), an elderly but very active Gavião woman. The interviewer and translator/analytic informant was a young Gavião man, João Sebirop da Silva (known as Cipiábíit or Basapeé in Gavião). A few days prior to the interview someone had brought Bojá clay from the forest. She decided it was suitable for pottery and began making pots again for the first time in a number of years.

The Portuguese translation is rendered into English as closely as possible. The letter 'J' after the sentence (or sentence fragment) number indicates that João is the speaker. The letter 'B' indicates that Bojá is the speaker.

Vacant nodes (e.g. a null Pre-S) are not shown in the structure diagrams. The matrix S node, which always dominates the matrix S', Pre-S, and Post-S nodes, is not shown except inside Utterance/Thoughts. The matrix S' node is likewise not shown (except inside Utterance/Thoughts), but its immediate constituents each have a short vertical line segment under them to indicate that they are immediately dominated by the matrix S'. Isolated particles are designated Prt.

Relevant nominal construction type features and values are given, but these are not shown on lower-ranking categories if they can be predicted from the feature values of higher-ranking categories. For example, the N'st head of a pALN NP'st must also be pALN. The feature CTRL 'control' and its value are indicated where relevant. Sentence functional type is indicated only on auxiliary stems and embedded clauses.

TEXT: An Interview with Grandmother about Making Pottery

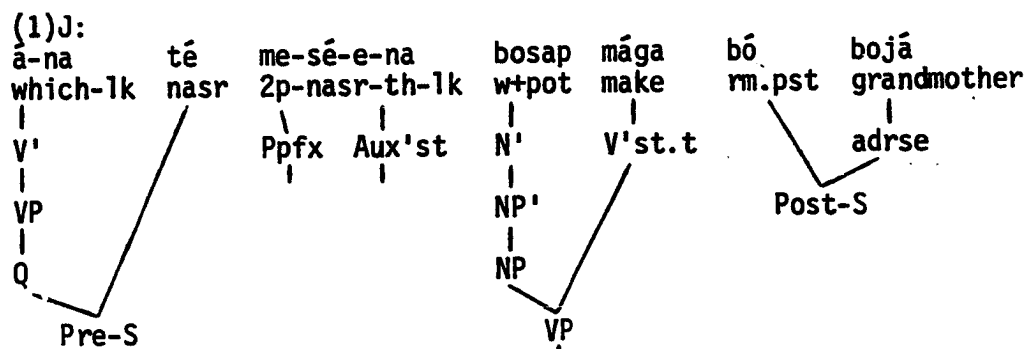

'How is it that you make pots, Grandmother?'

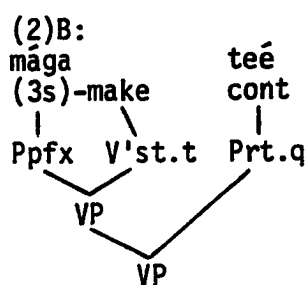

'Make (them).'

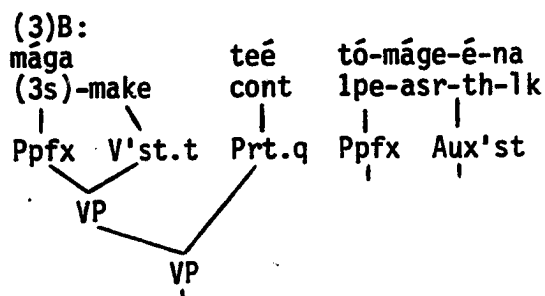

'We make (them).'

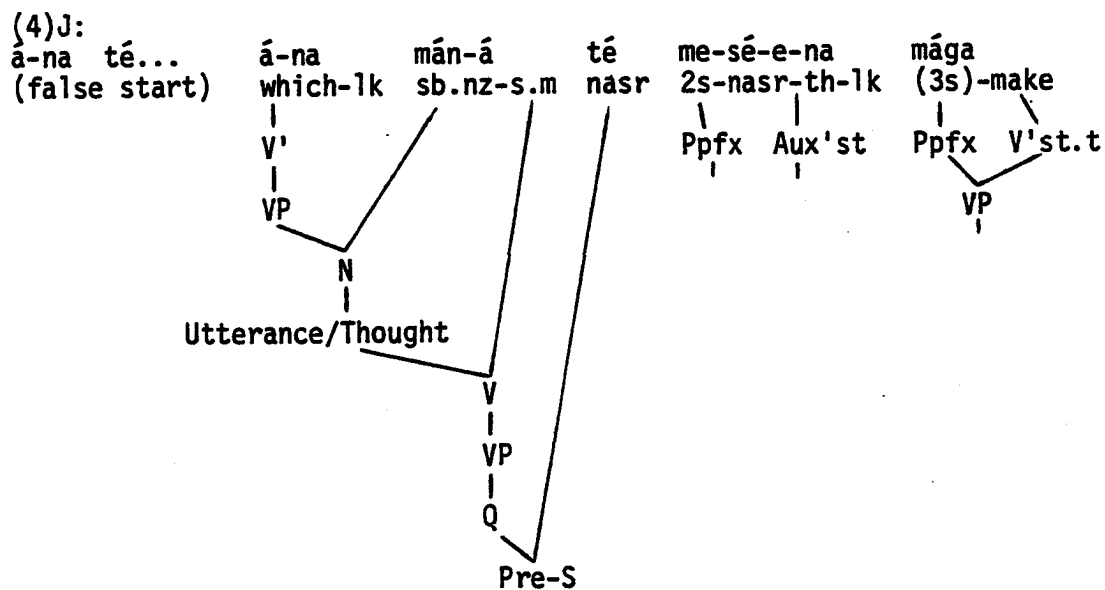

'Why is it that you make (them)?' (more literally: 'You make (them) thinking what?')

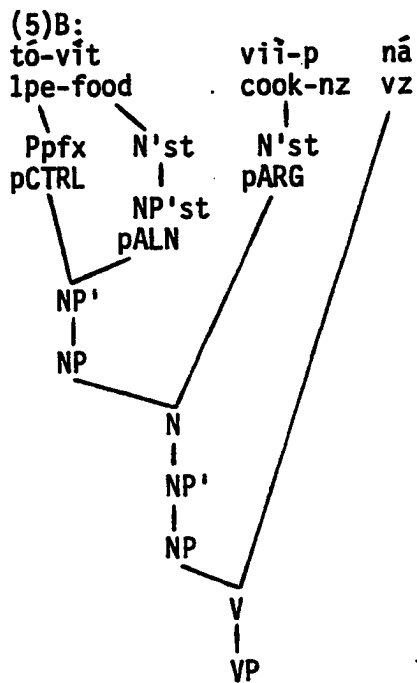

'To be something for cooking
 our food.'

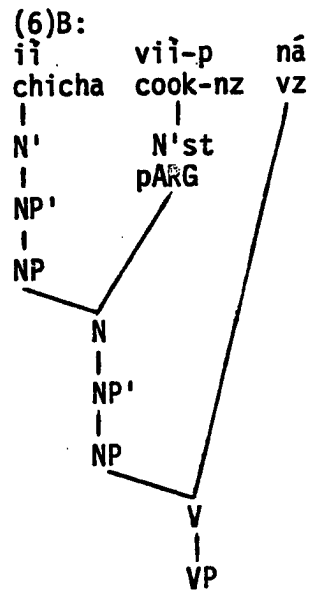

'To be something for making
 chicha.'

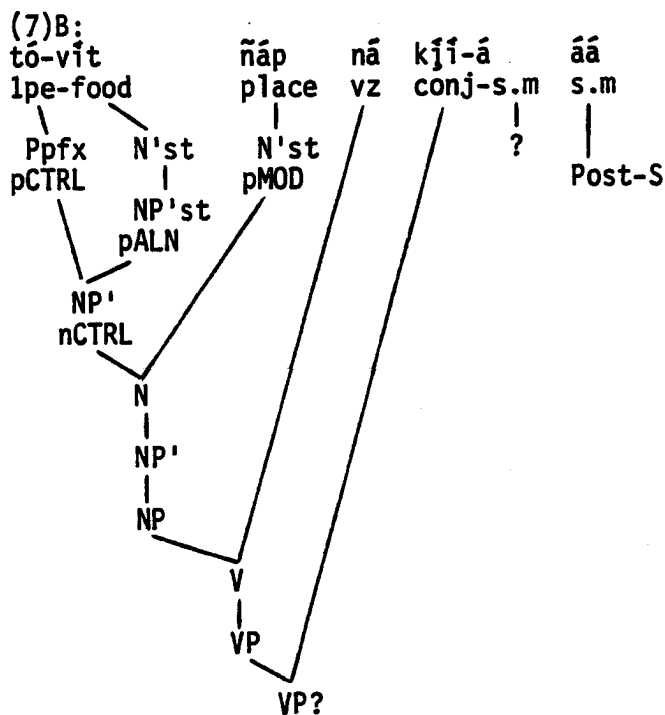

'To be a place for our food also.'

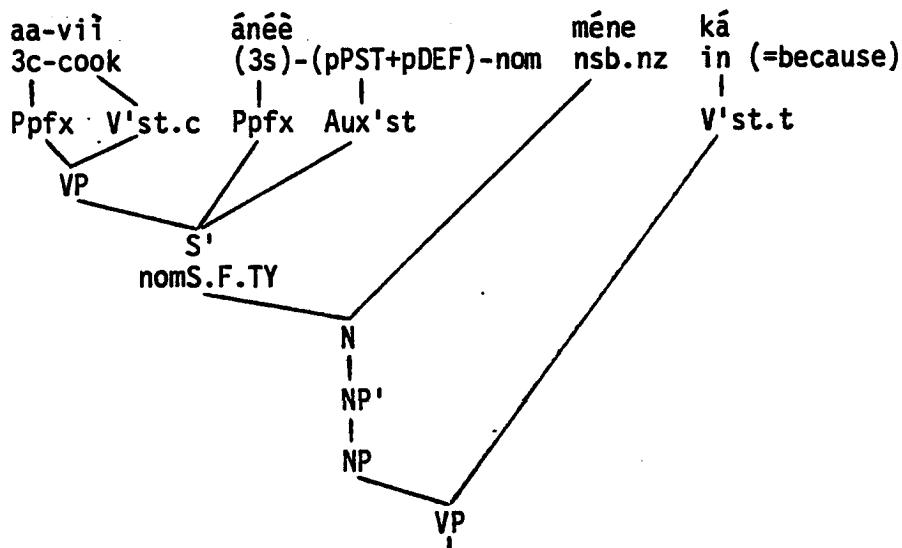
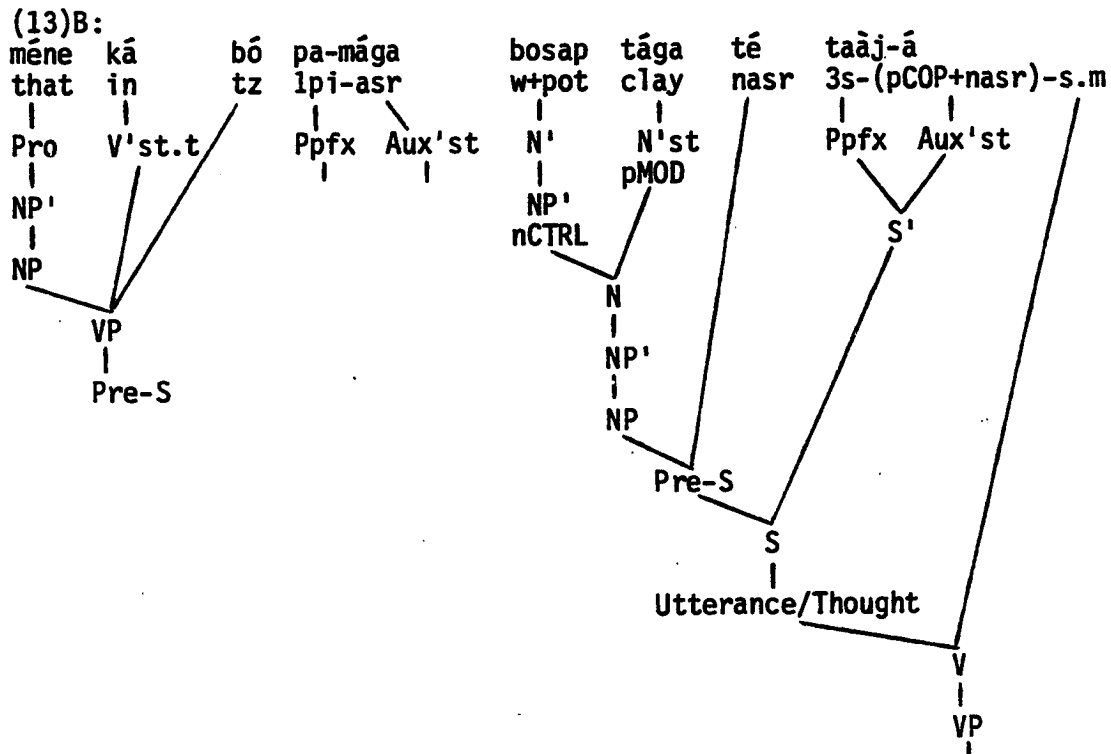

'Then we know that it is clay which can be fired.' or: 'Then we know it is pottery clay because it will fire.'

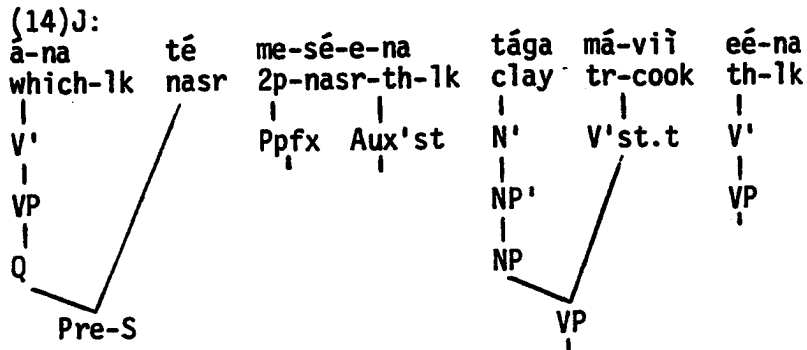

'How is it that you fire the clay?'

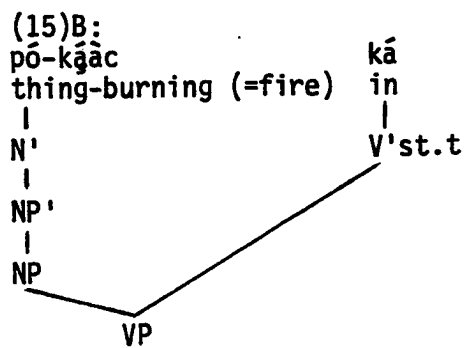

'In the fire.'

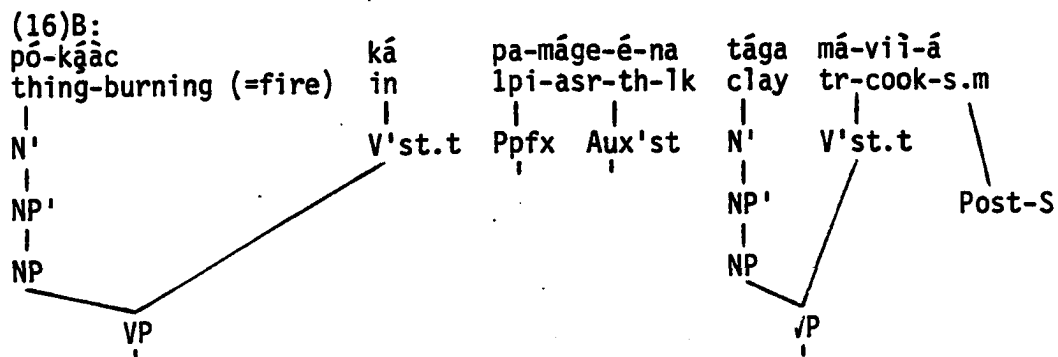

'We heat the clay in the fire.'

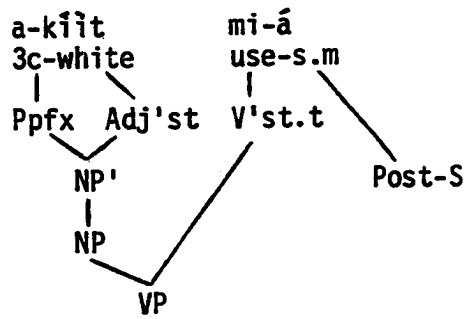

'Yes. It heats in a bark fire, becoming white.'

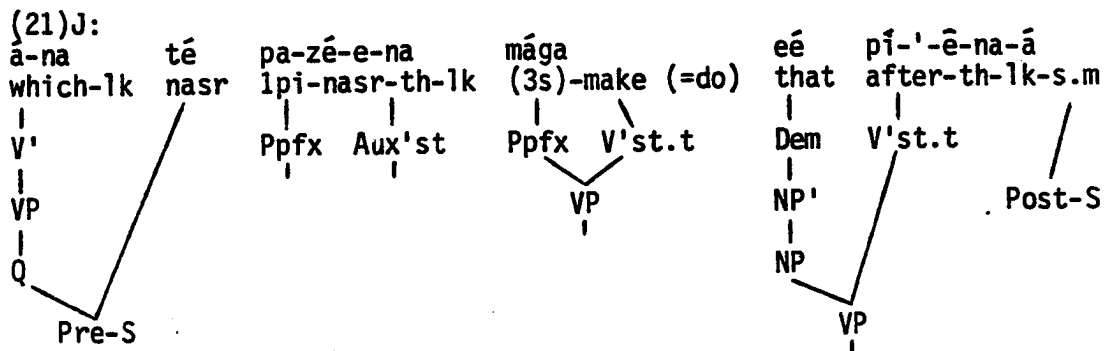

'What do we do with it after that?'

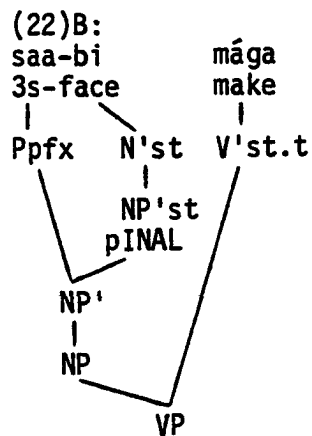

'Make its walls.'

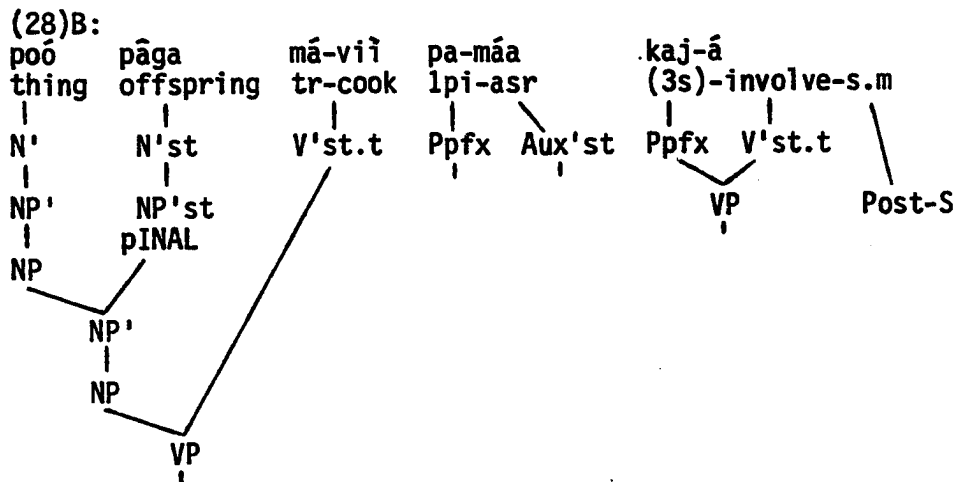

'We cook game with it.'

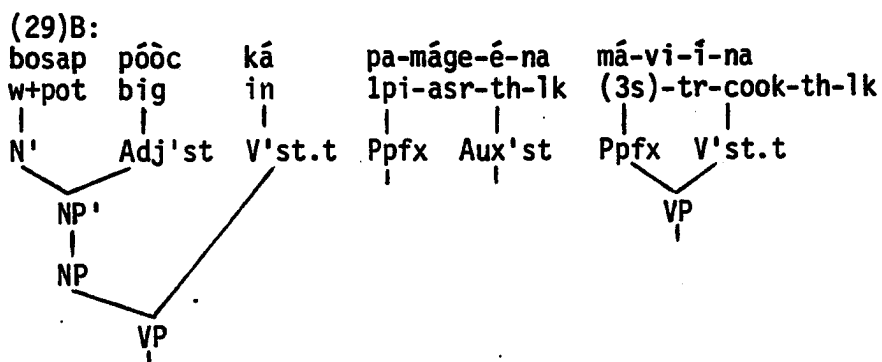

'We cook in a big pot.'

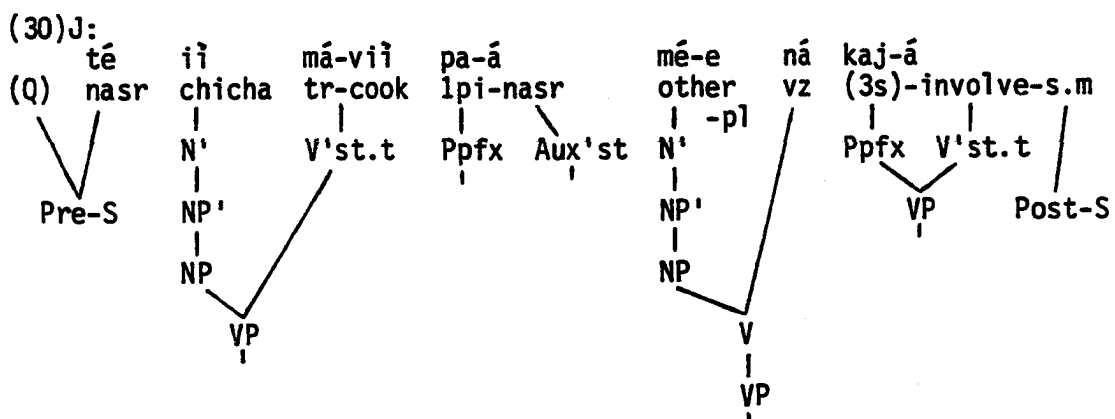

'We cook chicha in it also?'

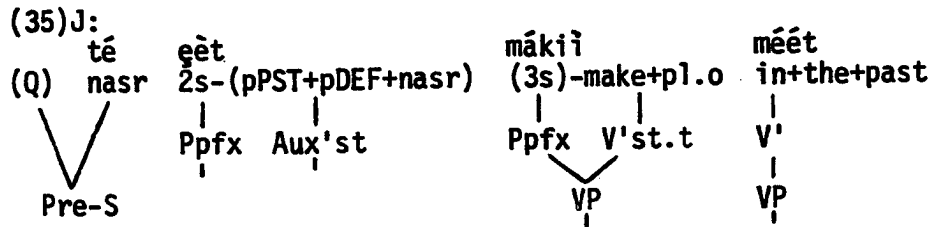

'Did you make (them) in the past, Grandmother?'

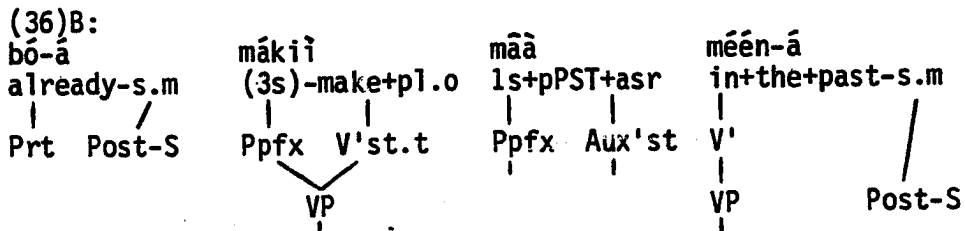

'Yes. I made (them) in the past.'

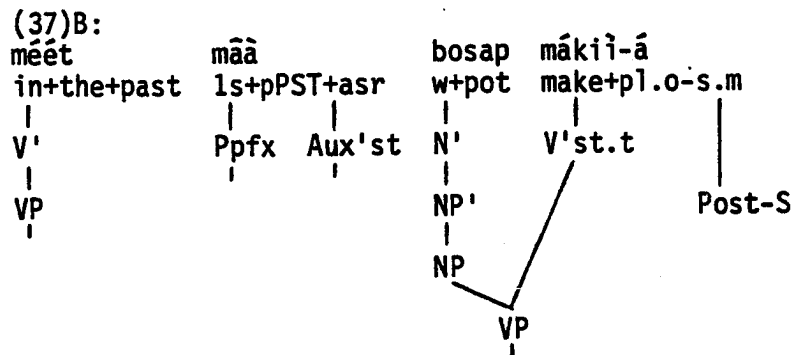

'In the past I made pots.'

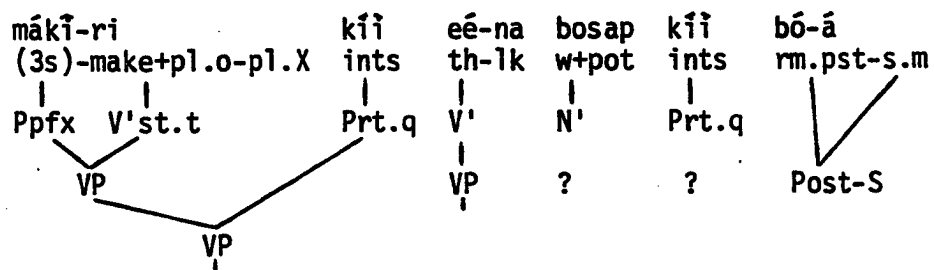
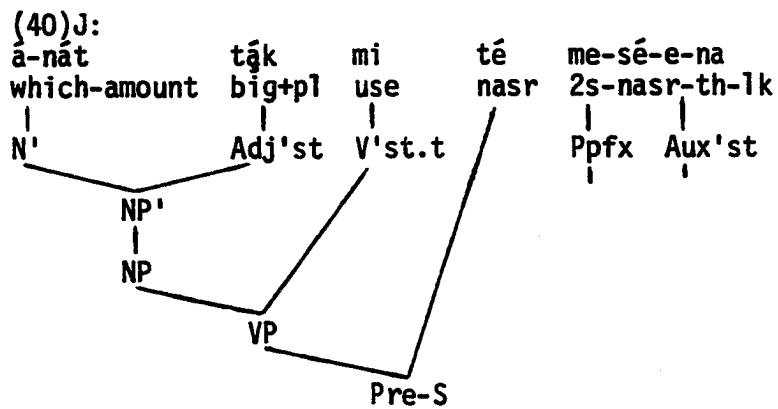

'How big did you make them?'

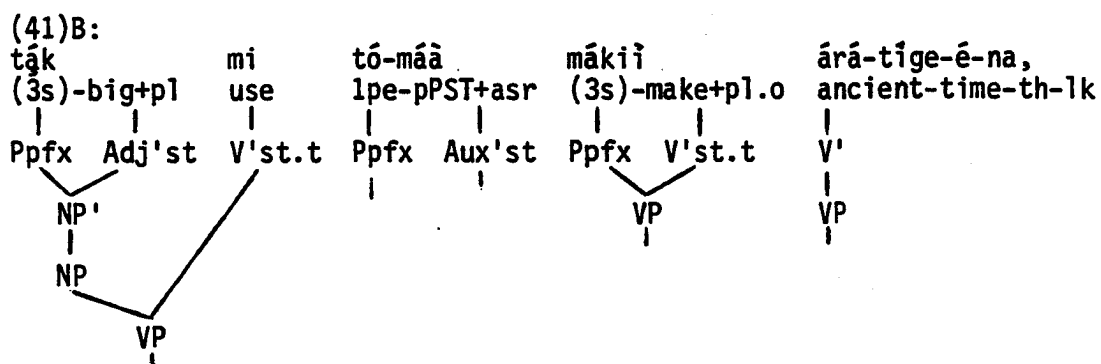

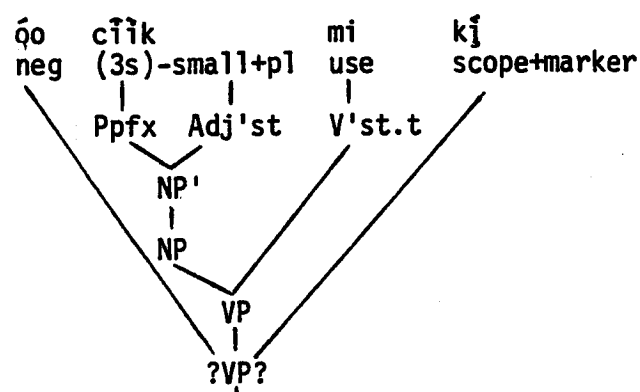
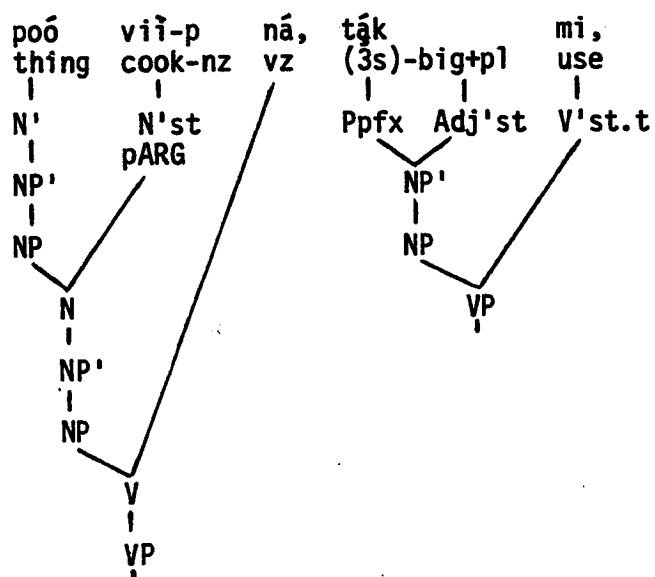

'We made big (ones), to cook things, big (ones), not little (ones).'

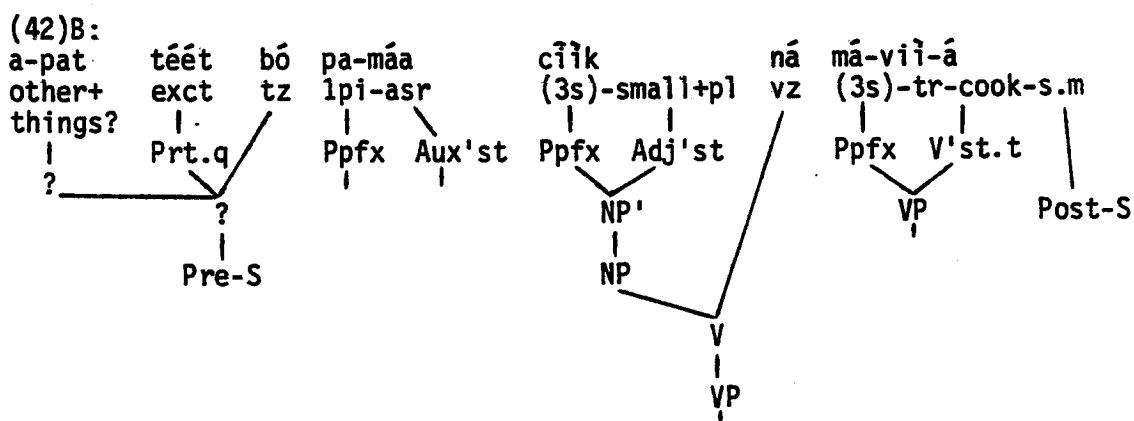

'Other things we make small.'

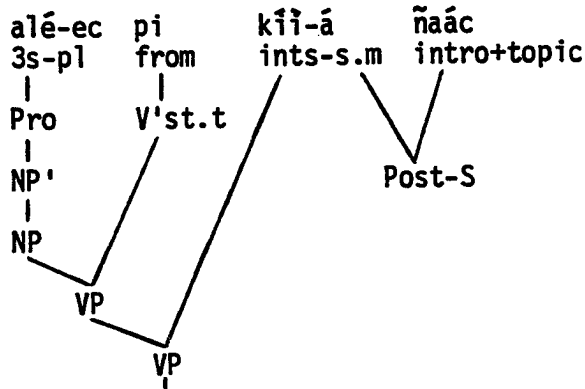
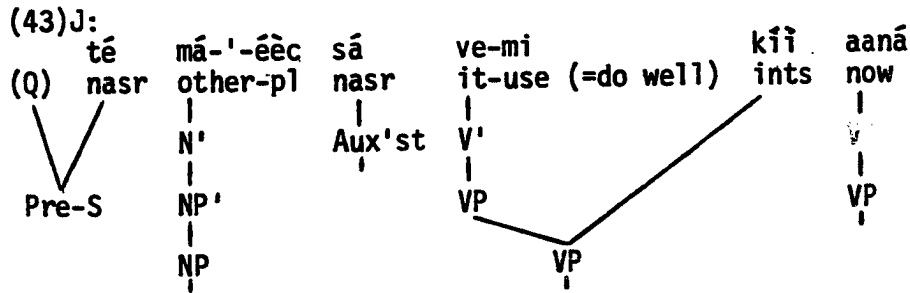

'Are there others among you who know how (to make pottery) now?'

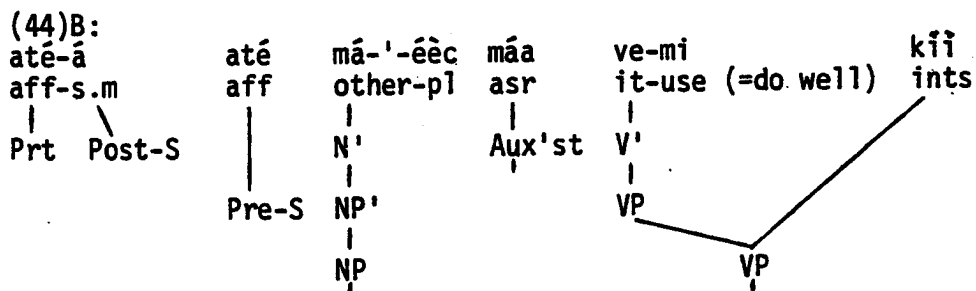

'Yes. There are others who know how.'

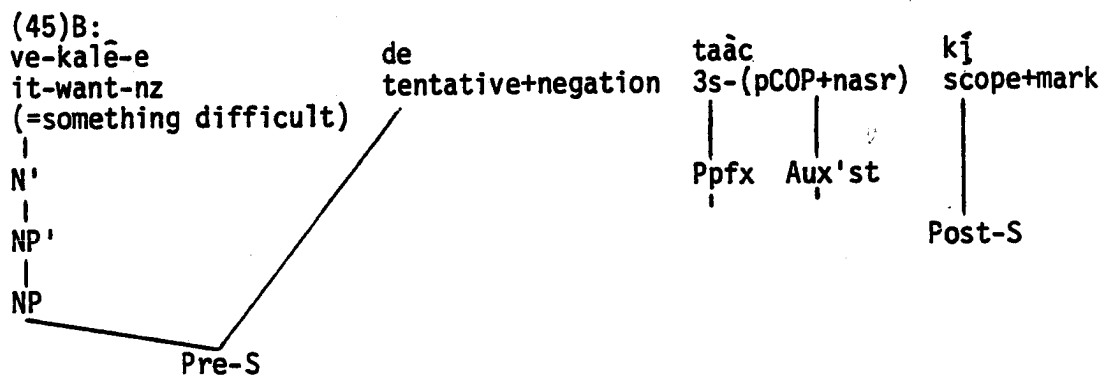

The constituent structure of each text sentence is given by its structural diagram. The rewrite rule which generates a particular constituent can be found by consulting the appropriate summary of phrase structure rules. There are four of these.

Section 8.1 (p. 137) lists the phrase structure rules from Sections 4.0, 5.0, 6.0, and 7.0, where the rewrite rules for the following symbols are presented: S, S', Aux'st, Pre-S, DemP, Q, Post-S, and addressee.

Section 9.5 (p. 157) summarizes the phrase structure rules for NP constituents, presenting rewrite rules for the following categories: NP, NP', and NP'st.

Section 10.5 (p. 172) summarizes the possible rewrites of VP.

Section 12.5 (pp. 220-22) summarizes the phrase structure rules for complex words and word stems, presenting rewrite rules for the following categories: N st, N, Adj st, V st.t, V st.c and V.

Comments on the text sentences are given below. For each sentence, any insertion rules, transformational rules, or phonosyntactic rules which apply to produce it are listed by their numbers. Whenever a sentence does not end in the syntactic marker -â, rule (7.68), -â Deletion, has obviously occurred, so this minor phonosyntactic rule will not be mentioned.

Insertions, transformations, and phonosyntactic rules are summarized in Sections 8.2 (p. 137), 8.3 (p. 138), and 8.4 (p. 139), respectively. These are repeated below for easy reference:

(7.33) WH Insertion (p. 115)

(7.36) Discourse Pronoun Insertion (p. 116)

- (6.63) Mood and Aspect Adjustment (p. 95)
- (6.64) Auxiliary Stem Person Prefix S.I. Value Assignment (p. 96)
- (7.37) Predicate NP Preposing within S' (revised) (p. 117)
- (7.38) {VP, S', S'-á} Preposing within S' (revised) (p. 118)
- (7.45) Preposing into S (p. 121)
- (7.52) Scope Marker Placement (p. 125)
- (7.57) Topicalization Particle Attachment (p. 127)
- (7.58) Third Person Singular Insertion (p. 127)
- (7.66) Addressee Postposing (p. 135)
- (7.68) -á Deletion (p. 135)
- (7.70) á Epenthesis (p. 136)

Text Sentences: Comments and Rules

- (1) Rules: (7.33), (6.64), (7.38), and (7.45).
- (2) Sentence fragment.
- (3) Rules: (6.63), (6.64), and (7.38).
- (4) The attributed thought containing the demonstrative á 'which' is indirect; see Section 12.2.3, pp. 186-87. Rules: (7.33), (6.64), (7.38), and (7.45).
- (5) Sentence fragment.
- (6) Sentence fragment.
- (7) Sentence fragment. The structure of constructions formed by kíí 'conjunction' is uncertain; see Section 11.0, pp. 173-75. Rule: (7.70).
- (8) Within the attributed thought the following rules apply: (6.64), (7.37), and (7.45). Outside the attributed thought the following rules apply: (7.33), (6.64), (7.38), and (7.45).

- (9) Sentence fragment.
- (10) Rules: (6.63), (6.64), and (7.38).
- (11) Rules: (6.64), (7.38), and (7.45).
- (12) Rules: (7.36), (6.63), (6.64), (7.38), (7.45), and (7.57).
- (13) Two informants feel this sentence is awkward. They suggest that the first translation given is what Bojá meant, but the second translation is what she actually said. Notice the hypothetical past tense in the embedded S'. Rules within the attributed thought: (6.64), (7.37), and (7.45). Rules within the embedded S': (6.64) and (7.38). Rules elsewhere: (7.36), (6.63), (6.64), (7.38), (7.45), and (7.57).
- (14) Rules: (7.33), (6.64), (7.38), and (7.45).
- (15) Sentence fragment.
- (16) Rules: (6.63), (6.64), and (7.38).
- (17) Sentence fragment.
- (18) Rules: (6.63), (6.64), and (7.38).
- (19) Rules: (6.64), (7.38), and (7.45).
- (20) Short answer followed by a sentence. Rules: (6.63), (6.64), and (7.38).
- (21) Rules: (7.33), (6.64), (7.38), and (7.45).
- (22) Sentence fragment.
- (23) It is unclear if the morpheme glossed 'thing' in the third VP is the particle pát; see Section 12.3.5, pp. 199-200. Rules: (6.63), (6.64), and (7.38).
- (24) Rules: (6.63), (6.64), and (7.57).
- (25) Rules: (6.63), (6.64), (7.38), (7.45), and (7.57).
- (26) Rules: (6.64), (7.38), and (7.45).

- (27) Rules: (6.63), (6.64), and (7.38).
- (28) Rules: (6.63), (6.64), and (7.38).
- (29) Rules: (6.63), (6.64), and (7.38).
- (30) Rules: (6.64) and (7.38).
- (31) Rules: (6.63), (6.64), and (7.38).
- (32) Sentence fragment.
- (33) Sentence fragment.
- (34) Rules: (6.63), (6.64), and (7.38).
- (35) Rule: (6.64).
- (36) Short answer followed by a sentence. Rules: (6.63), (6.64), and (7.38).
- (37) Rules: (6.63), (6.64), and (7.38).
- (38) The time-of-evidence particle kí-ná+po 'proximate time of evidence' is used to remind the hearer, João, that he knew of the lack of pottery production in recent times. This particle triggers subjective mood. Rules: (6.63), (6.64), (7.38), (7.45), and (7.57).
- (39) Rules: (6.63), (6.64), and (7.38).
- (40) Apparently the speaker added the direct object, bosap 'pot(s)', as an afterthought. Possibly the sequence kîî bô is an error for kî-bô 'remote past time of evidence'. Rules: (7.33), (6.64), (7.38), and (7.45).
- (41) The structure of constructions formed with ôo...kî (//ô'q...kî//) is not yet determined, see Section 7.7, p. 128. Rules: (6.63), (6.64), and (7.38).
- (42) According to the informant, a-pat (apat?) means 'other things'. The form class of this expression is undetermined. Rules:

(6.63), (6.64), possibly (7.38), possibly (7.45), and (7.57).

- (43) No rules.
- (44) Short answer followed by a sentence. Rule: (6.63).
- (45) Rules: (6.64), (7.37), (7.45), and (7.52).
- (46) The glosses of the component morphemes of the expression q bó na 'could be...' are perhaps correct, but the structural composition of the whole cannot be stated at this time. No rules.
- (47) Short answer.
- (48) Rules: (6.63), (6.64), and (7.38).
- (49) Rules: (6.63), (6.64), and (7.38).
- (50) Rules: (6.63), (6.64), and (7.38).
- (51) Short answer.
- (52) No rule.
- (53) Short answer.
- (54) Rule: (6.64).

REFERENCES CITED

- Akmajian, Adrian, and Frank W. Heny. 1975. An introduction to the principles of transformational syntax. Cambridge, MA: The MIT Press.
- Bendor-Samuel, David, ed. 1971. Tupi Studies I. Norman, Oklahoma: Summer Institute of Linguistics.
- _____. 1972. Hierarchical structures in Guajajara. Norman, Oklahoma: Summer Institute of Linguistics.
- Bontkes, Willem. 1978. Dicionário preliminar Suruí-Português, Português-Suruí, edição preliminar. Mimeographed. Porto Velho, Rondônia: Summer Institute of Linguistics.
- Campbell, Robert. 1968. Aruá wordlist. Ms. Brasília: Fundação Nacional do Índio.
- Crofts, Marjorie. 1973. Gramática Mundurukú. Série Lingüística 2. Brasília: Summer Institute of Linguistics.
- Cultural Survival, Inc. 1981. In the path of Polonoroeste: endangered peoples of western Brazil. Occasional Paper 6. Cambridge, MA: Cultural Survival, Inc.
- Firestone, Homer L. 1965. Description and classification of Sirionó. The Hague: Mouton.
- Gazdar, Gerald, Geoffrey K. Pullum, and Ivan A. Sag. 1982. Auxiliaries and related phenomena in a restrictive theory of grammar. Language 58: 591-638.
- Gregores, Emma, and Jorge A. Suárez. 1967. A description of colloquial Guarani. The Hague: Mouton.
- Hanke, Wanda. 1950. Breves notas sobre os índios Mondé e o seu idioma. Dusenía 1: 215-228. Curitiba.
- Harrison, Carl H. 1975. Gramática Asuriní: Aspectos de uma gramática transformacional e discursos monologados da língua Asuriní, família Tupí-Guaraní. Série Lingüística 4. Brasília: Summer Institute of Linguistics.
- Landin, David J. 1980. An outline of the syntactic structure of Karitiana sentences. M.A. thesis, University College London.
- Lathrap, Donald W. 1970. The upper Amazon. New York: Praeger.
- Lévi-Strauss, Claude. 1967. Tristes tropiques, trans. by John Russell. New York: Atheneum.

- Meggers, Betty J. 1975. Application of the biological model of diversification to cultural distributions in lowland South America. *Biotropica* 7(3): 141-161
- Mello Leonel Junior, Mauro de. 1983. Relatório de avaliação da situação dos Gavião (Digüt) - P.I. Lourdes. São Paulo: Fundação Instituto de Pesquisas Econômicas, SUDECO, Ministério do Interior do Brasil.
- Mindlin, Betty. 1983. Relatório de avaliação da situação dos Arara (Karo) - P.I. Lourdes. São Paulo: Fundação Instituto de Pesquisas Econômicas, SUDECO, Ministério do Interior do Brasil.
- _____, and Carmen Junqueira de B. Lima. 1983. Avaliação do Parque Indígena do Aripuanã. São Paulo: Fundação Instituto de Pesquisas Econômicas, SUDECO, Ministério do Interior do Brasil.
- Moore, Denny. 1981. The Gavião, Zoró, and Arara Indians. In the path of Polonoroeste: endangered peoples of western Brazil. Cultural Survival Occasional Paper 6. Cambridge, MA: Cultural Survival, Inc.
- Rodrigues, Aryon Dall'Igna. 1958. Classification of Tupí-Guaraní. *IJAL* 24: 231-234.
- _____. 1962. A classificação do tronco lingüístico Tupí. *Revista de Antropologia* 12: 99-104.
- _____. 1974. Linguistic groups of Amazonia. *Native South Americans: ethnology of the least-known continent*, ed. by Patricia J. Lyons, 51-58. Boston & Toronto: Little, Brown & Co., Inc.
- Schultz, Harald. 1955. Vocabulos Urukú e Digüt. *Journal de la Société des Americanistes de Paris*, n.s., 44: 81-97.